

EMEA

# Rubber hydraulic hose and fitting, tooling and accessories catalog



  
by Danfoss

**Winner**  
by Danfoss



# Rubber Hydraulics

## product overview

All your fluid conveyance needs

<p>Rubber Hydraulic Introduction 4</p> <div style="border: 1px solid black; height: 20px; width: 260px; margin-bottom: 5px;"></div> <p>Hose selection chart STAMPED worksheet Two-tier product portfolio</p>	<p>Premium Hydraulic Hose 33</p> <div style="background-color: red; height: 20px; width: 260px; margin-bottom: 5px;"></div> <p>Braided Spiral</p>	<p>Standard Hydraulic Hose 61</p> <div style="background-color: #800000; height: 20px; width: 260px; margin-bottom: 5px;"></div> <p>Braided Spiral</p>
<p>Braided Fittings 79</p> <div style="background-color: #444; height: 20px; width: 260px; margin-bottom: 5px;"></div> <p>Premium - 1A and 1G series Reusable - 1R and 2R series Standard - Winner series</p>	<p>Spiral Fittings 173</p> <div style="background-color: #666; height: 20px; width: 260px; margin-bottom: 5px;"></div> <p>Premium - 1T/4S/6S series Premium - 1W series</p>	<p>Hose Accessories 237</p> <div style="background-color: #999; height: 20px; width: 260px; margin-bottom: 5px;"></div> <p>Sleeves Clamps Springs</p>
<p>Machines &amp; Tooling 251</p> <div style="background-color: #ccc; height: 20px; width: 260px; margin-bottom: 5px;"></div> <p>Crimp machines Cutting machines Skiving machines Nipple inserters Marking machines</p>	<p>Safety Information 291</p> <div style="background-color: black; height: 20px; width: 260px; margin-bottom: 5px;"></div> <p>Hose safety Hose selection Fluid compatibility Analyzing failures</p>	<p>Glossery &amp; index 335</p> <div style="background-color: #808080; height: 20px; width: 260px; margin-bottom: 5px;"></div> <p>Glossery Index</p>

# Explore the world of Danfoss fluid conveyance

From thermoplastic hose to data center connections, Danfoss has the hose, fittings and connectors that work.

## Connectors



## Fuel, air conditioning, thermoplastic & specialty



### Product Categories:

- |                            |                |
|----------------------------|----------------|
| Brass Connectors           | Steel Adapters |
| Flexmaster                 | Swivels        |
| FLOCS                      | Tube Fittings  |
| Quick Disconnect Couplings |                |

### Learn more:

- STC catalog  
AI426662111733en
- Steel Adapters catalog  
AI426662111733en
- Waltech tube fittings catalog  
AF403661682130en

### Product Categories:

- |                      |                  |
|----------------------|------------------|
| A/C & Refrigeration  | Railway          |
| Airbrake             | Silicone         |
| Beverage Tubing      | Socketless       |
| Engine/Fuel          | Specialty        |
| Performance Products | Subsea Oil & Gas |
| PTFE                 | Thermoplastic    |

### Learn more:

- PTFE catalog  
AI426662111733en
- Air conditioning catalog  
AI426662111733en



## Rubber hydraulic hose & fittings



### Product Categories:

- Braided Hose & Fittings
- Spiral Hose & Fittings
- Tools, Machines & Accessories
- Industrial Transfer-Type Hoses

### Learn more:

- [Core rubber hydraulic hoses catalog EMEA AF451853493784en](#)
- [Winner hoses and fittings catalog EMEA AF452060694223en](#)
- [Tooling machines and accessories catalog EMEA AF439850542947en](#)
- [Industrial hose catalog: AF423242185650en](#)

## Hose selection chart

**How to use chart:** Locate the hose I.D. required and move to the right to the correct pressure. Then move up or down in this column for data on material, temperature, etc. to quickly determine whether the hose meets your requirements.

For complete information on any hose refer to hose catalog page number.

Core hoses are indicated with icons:

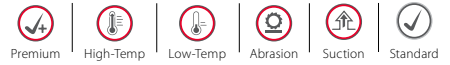

**Selection of hose:** Selection of the proper hose for the application is essential to the proper operation and safe use of the hose and related equipment. Inadequate attention to selection of the hose for your application can result in hose leaking, bursting, or other failure which can cause serious bodily injury or property damage from spraying fluids or flying projectiles. You should carefully review the information in this catalog.

Premium hose selection chart							
Core braided hoses							
Hose	GH681	FC510	GH781	EC881	GH195	GH120	
Page	36	37	38	39	40	41	
Usage							
	For low to medium pressure hydraulic systems applications where surpassing the 1SC standard is needed. Qualified to one million impulse cycles.	For applications operating in high temperature- with AQP inner tube up to 150°C. Hi-Pack reinforcement for increased pressure and impulse.	For medium pressure diverse applications where all-round premium performance, and enhanced flexibility needed.	For medium to high pressure, extra demanding applications requiring high performance- EC881 offers one million impulse cycle performance and 1/3 SAE bend radius.	For applications operating in high temperature or with higher hydraulic fluid temperature- with AQP inner tube up to 150°C.	For applications operating in low temperature conditions, cold climate down to -57°C, for general hydraulic service.	
<b>Certifications</b>							
EN	EN 857 1SC	EN 857 1SC	EN 857 2SC	EN 857 2SC	EN 853 2SN	EN 857 2SC	
ISO	ISO 1436 1SN ISO 18752		ISO 18752	ISO 18752 ISO 11237-1	ISO 1436-1 2SN	ISO 11237-1 2SC	
SAE	SAE 100R17		SAE 100R16	SAE 100R16 SAE 100R19	SAE 100R2	SAE 100R16	
OTHER	ABS DNV MSHA USCG	DNV MSHA USCG	ABS DNV MSHA USCG	ABS DNV MSHA	ABS DNV MSHA USCG	MSHA	
<b>Hose Specifications</b>							
Temp Range	-46° to 126° C -50° to 260° F	-40° to 150° C -40° to 302° F	-46° to 126° C -50° to 260° F	-46° to 126° C -50° to 260° F	-40° to 150° C -40° to 302° F	-57° to 100° C -70° to 212° F	
Fittings	1A Series 1R Series	1A Series	1A Series 2R Series	1A Series	1A Series	1A Series	
<b>Hose Construction</b>							
Inner Tubes	Synthetic rubber	AQP High- Temp	Synthetic rubber	Dura-Pulse	AQP High- Temp	Special low temperature synthetic rubber	
Reinforcement	1 wire braid	1 wire braid	2 wire braid	2 wire braid	2 wire braid	2 wire braid	
Cover	Dura-Tuff	Blue AQP elastomer	Dura-Tuff	Dura-Tuff	Blue AQP elastomer	Dura-Tuff	
<b>Maximum operating pressure (BAR)</b>							
DASH	HOSE ID	GH681	FC510	GH781	EC881	GH195	GH120
-4	1/4	255	345	448	450	400	414
-6	3/8	235	275	400	400	345	345
-8	1/2	221	240	350	360	293	310
-10	5/8	140	190	280	350	250	276
-12	3/4	138	155	240	330	215	241
-16	1	103	138	210	280	175	193
-20	1-1/4	69	112	172	172	155	159
-24	1-1/2	52		140	138	125	138
-32	2	41		110	110	105	103
-40	2-1/2						
-48	3						
-64	4						

## Hose selection chart

**How to use chart:** Locate the hose I.D. required and move to the right to the correct pressure. Then move up or down in this column for data on material, temperature, etc. to quickly determine whether the hose meets your requirements.

For complete information on any hose refer to hose catalog page number.

Core hoses are indicated with icons:



Premium hose selection chart								
Spiral hose		Core spiral hoses						
Hose	GH425	GH493	GH506	FC500	GH466	EC600	EC850	
Page	42	43	44	45	46	47	48	
Usage								
	High pressure hydraulic system service with petroleum and enhanced compatibility for water-based fluids.	Versatile high pressure hose that exceeds four leading industry standards. Up to one million impulse cycles, high pressure tolerance and flexibility.	High pressure, challenging hydraulic systems. 2 Million flex impulse cycle performance according ISO6802 for size 12' and 16'.	High pressure hydraulic system service for general industrial service where extra flexibility needed.	High pressure hydraulic systems with constant high working pressure. 2 Million flex impulse cycle.	For applications where extra flexibility and high pressure is needed.	Ultra high pressure applications at pressures up to 500 bar and long lifecycle-delivering up to 3 million impulse cycle performance in sizes -10 and -12.	
<b>Certifications</b>								
EN	EN 856 4SP	EN 856 R12 EN 856 4SP	EN 856 4SH	EN 856 R13	EN 856 R13		EN 856 R13	
ISO		ISO 3862 R12	ISO 3862 4SH ISO 18752	ISO 3862 R13	ISO 3862 R15	ISO 18752-DC	ISO 18752	
SAE		SAE 100R12		SAE 100R13	SAE 100R15	SAE 100R15	SAE 100R15	
OTHER	ABS DNV MSHA	ABS DNV MSHA USCG	ABS DNV MSHA	MSHA USCG	ABS DNV MSHA	ABS DNV MSHA USCG	MSHA	
<b>Hose Specifications</b>								
Temp Range	-40° to 100° C -40° to 212° F	-40° to 126° C -40° to 260° F	-40° to 100° C -40° to 212° C	-40° to 127° C -40° to 260° F	-40° to 121° C -40° to 250° F	-40° to 121° C -40° to 250° F	-40° to 100° C -40° to 212° F	
Fittings	1T Series 4S Series	1T Series 4S Series	1W Series	4S Series 6S Series	1W Series 6S Series	4S Series 6S Series 1W Series	1W Series	
<b>Hose Construction</b>								
Inner Tubes	Synthetic rubber	Synthetic rubber	Synthetic rubber	Synthetic rubber	Synthetic rubber	Dura-Pulse	Synthetic rubber	
Reinforcement	4 wire spiral	4 wire spiral	4 wire spiral	4 wire spiral or 6 wire spiral	6 wire spiral	4 wire spiral or 6 wire spiral	4 wire spiral or 6 wire spiral	
Cover	Dura-Tuff	Dura-Tuff	Dura-Tuff	Dura-Tuff	Dura-Tuff	Dura-Tuff	Dura-Tuff	
<b>Maximum operating pressure (BAR)</b>								
DASH	HOSE ID	GH425	GH493	GH506	FC500	GH466	EC600	EC850
-4	1/4							
-6	3/8	490	448					
-8	1/2	420	415					
-10	5/8	420	415					500
-12	3/4	380	380	420	350		420	500
-16	1	320	350	420	350		420	500
-20	1-1/4		310	350	350	420	420	500
-24	1-1/2		275	300	350	420	420	
-32	2		275	250	350	420	420	
-40	2-1/2							
-48	3							
-64	4							

## Hose selection chart

**How to use chart:** Locate the hose I.D. required and move to the right to the correct pressure. Then move up or down in this column for data on material, temperature, etc. to quickly determine whether the hose meets your requirements.

For complete information on any hose refer to hose catalog page number.

Core hoses are indicated with icons:

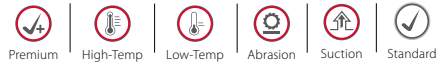

Premium hose selection chart							
	Core spiral hoses		Core suction hose	Suction hose	Braided speciality hoses		
Hose	EC525	EC810	FC619	2661	GH585	FC310	
Page	49	50	51	52	53	54	
Usage	For applications operating in high temperature or with higher hydraulic fluid temperature- with AQP inner tube up to 150° C.	For applications operating in low temperature conditions, cold climate down to -57° C, for general hydraulic service.	Suction and delivery hose also for high temperature up to 135° C, for hydraulic fluids, fuel, lubricating oils, gasoline, water and many other industrial fluids.	Suction and delivery hose also for high temperature up to 149° C, for hot environments, for hydraulic fluids, fuel, lubricating oils, fuel, lubricating oils, gasoline, water and many other industrial fluids.	Two textile braided hose, for use in hydraulic systems with petroleum base fluids for fuel and lubricating oils, air and water.	Hi-Pac(kage) hose with higher volume of braiding for mining applications to increase the pressure and impulse performance.	
Certifications							
EN	EN 856 R12		EN 45545		EN 854 2TE		
ISO							
SAE	SAE 100R12		SAE 100R4	SAE 100R4		SAE 100R2	
OTHER	MSHA	MSHA	ABS MSHA	MSHA USCG	MSHA	DNV MSHA	
Hose Specifications							
Temp Range	-40° to 149° C -40° to 300° F	-57° to 100° C -70° to 212° F	-40° to 135° C -40° to 275° F	-40° to 149° C -40° to 300° F	-40° to 100° C -40° to 212° F	-40° to 100° C -40° to 212° F	
Fittings	4S Series	4S Series 6S Series 1W Series	1A Series 1G Series 4S Series	1A Series 1G Series	1G Series	1A Series	
Hose Construction							
Inner Tubes	AQP High- Temp	Synthetic rubber	AQP High- Temp	AQP High- Temp	Synthetic rubber	Synthetic rubber	
Reinforcement	4 wire spiral	4 wire spiral or 6 wire spiral	2 fiber ply with helical wire	2 fiber ply with helical wire	1 textile braid	1 wire braid	
Cover	Blue AQP elastomer	Synthetic rubber	Synthetic rubber	Blue AQP elastomer	Synthetic rubber	Synthetic rubber	
Maximum operating pressure (BAR)							
DASH	HOSE ID	EC525	EC810	FC619	2661	GH585	FC310
-4	1/4					75	345
-6	3/8		420			63	275
-8	1/2		420			58	240
-10	5/8		420			50	190
-12	3/4	345	420	21	21	45	155
-16	1	345	420	17	17.5	40	138
-20	1-1/4	240	420	14	14		112
-24	1-1/2	240	420	10.5	11		
-32	2	225	420	7	7		
-40	2-1/2			4	4.5		
-48	3			4	4		
-64	4				3.5		



## Hose selection chart

**How to use chart:** Locate the hose I.D. required and move to the right to the correct pressure. Then move up or down in this column for data on material, temperature, etc. to quickly determine whether the hose meets your requirements.

For complete information on any hose refer to hose catalog page number.

Core hoses are indicated with icons:



Premium hose selection chart							
		Braided speciality hose	Spiral speciality hoses		Core ultra-abrasion hoses		
Hose		SH222	GH507	GH435	GH681B	EC881B	GH425B
Page		55	56	57	58	59	60
Usage		Hi-Pac(kage) hose specifically designed for mining applications to increase the pressure and impulse performance.	Heavy wire hose for challenging applications. Use in high pressure hydraulic systems with petroleum and water-glycol based fluids.	For hydraulic systems with phosphate ester fluids (HFD). Great compatibility against aggressive fluids like due to the special inner tube.	One wire braided hose for challenging low to medium pressure applications, surpassing the standards significantly. With Bruiser cover this hose offers 700x higher abrasion resistance for challenging applications.	This Dynamax ultra-performance hose is for extra demanding applications requiring high performance. With Bruiser cover this hose offers 700x higher abrasion resistance for challenging applications.	Enhanced compatibility for water-based fluids. With Bruiser cover this hose offers 700x higher abrasion resistance for challenging applications.
<b>Certifications</b>							
EN		EN 853 2SN	EN 856 4SH		EN 857 1SC	EN 857 2SC	EN 856 4SP
ISO					ISO 1436 1SN ISO 18752	ISO 18752 ISO 11237-1 2SC	
SAE			SAE 100R15		SAE 100R16 S	SAE 100R16 S	
OTHER		MSHA	MSHA		DNV MSHA	DNV MSHA	DNV MSHA ABS
<b>Hose Specifications</b>							
Temp Range		-40° to 100° C -40° to 212° F	-40° to 120° C -40° to 248° F	-40° to 70° C -40° to 158° F	-46° to 126° C -50° to 260° F	-46° to 126° C -50° to 260° F	-40° to 100° C -40° to 212° F
Fittings		1A Series	1W Series	1T Series 4S Series	1A Series 1R Series	1A Series	1T Series 4S Series
<b>Hose Construction</b>							
Inner Tubes		Synthetic rubber	Synthetic rubber	Polyamide	Synthetic rubber	Dura-Pulse	Synthetic rubber
Reinforcement		2 wire spiral	4 wire spiral	4 wire spiral	1 wire braid	2 wire braid	4 wire spiral
Cover		Dura-Tuff	Synthetic rubber	Synthetic rubber	Bruiser ultra-abrasion	Bruiser ultra-abrasion	Bruiser ultra-abrasion
<b>Maximum operating pressure (BAR)</b>							
DASH	HOSE ID	SH222	GH507	GH435	GH681B	EC881B	GH425B
-4	1/4	400			255	450	
-6	3/8	350		490	235	400	490
-8	1/2	300		420	221	360	420
-10	5/8			400	140	350	420
-12	3/4	300		380	138	330	380
-16	1	240		320	103	280	320
-20	1-1/4		420		69	172	
-24	1-1/2				52	138	
-32	2				41	110	
-40	2-1/2						
-48	3						
-64	4						

## Hose selection chart

**How to use chart:** Locate the hose I.D. required and move to the right to the correct pressure. Then move up or down in this column for data on material, temperature, etc. to quickly determine whether the hose meets your requirements.

For complete information on any hose refer to hose catalog page number.

Core hoses are indicated with icons:

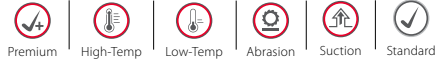

Standard hose selection chart									
	Braided hose	Core braided hose	Braided hose	Core braided hose	Braided hoses		Core braided hose	Braided hose	
Hose	EC110	EC115	EC210	EC215	EC118	EC082	EC426	EC512	
Page	64	65	66	67	68	69	70	71	
Usage		✓		✓			✓		
	Hydraulic system service with petroleum and water-based fluids, for general industrial service use.	Hydraulic system service with petroleum and water-based fluids and general industrial service use.	Hydraulic system service with petroleum and water-based fluids, for general industrial service use.	Hydraulic system service with petroleum and water-based fluids, for general industrial service use.	210 bar constant pressure hydraulic hose for low and medium pressure hydraulic systems with petroleum and water-based fluids.	One wire braided flexible hose designed for pilot lines, and general applications.	Hydraulic systems service with petroleum and water-based fluids, for general use.	Hydraulic systems service with petroleum and water-based fluids, for general use.	
<b>Certifications</b>									
EN	EN 853 1SN	EN 857 1SC	EN 853 2SN	EN 857 2SC			EN 856 4SP	EN 856 4SH	
ISO				ISO 18752	ISO 18752				
SAE	SAE 100R1	SAE 100R1	SAE 100R2		SAE 100R17				
OTHER	DNV MSHA	DNV USCG MSHA	DNV MSHA	DNV USCG MSHA	MSHA USCG	MSHA	MSHA	DNV MSHA	
<b>Hose Specifications</b>									
Temp Range	-40° to 100° C -40° to 212° F	-40° to 100° C -40° to 212° F	-40° to 100° C -40° to 212° F	-40° to 100° C -40° to 212° F	-40° to 100° C -40° to 212° F	-40° to 100° C -40° to 212° F	-40° to 100° C -40° to 212° F	-40° to 100° C -40° to 212° F	
Fittings	1A Series 2 pc Winner 1R Series	1A Series 2 pc Winner 1R Series	1A Series 2 pc Winner 2R Series	1A Series 2 pc Winner 2R Series	1A Series 2 pc Winner 1R Series (-4 to -8)	2 pc Winner	1T Series 4S Series 2 pc Winner	4S Series	
<b>Hose Construction</b>									
Inner Tubes	Synthetic rubber	Synthetic rubber	Synthetic rubber	Synthetic rubber	Synthetic rubber	Synthetic rubber	Synthetic rubber	Synthetic rubber	
Reinforcement	1 steel braid	1 wire braid	2 steel braid	2 wire braid	1 wire braid or 2 wire braid	1 steel braid	4 wire spiral	4 wire spiral	
Cover	Synthetic rubber	Synthetic rubber	Synthetic rubber	Synthetic rubber	Synthetic rubber	Synthetic rubber	Synthetic rubber	Synthetic rubber	
<b>Maximum operating pressure (PSI)</b>									
DASH	HOSE ID	EC110	EC115	EC210	EC215	EC118	EC082	EC426	EC512
-4	1/4	225	225	400	400	210	150		
-6	3/8	180	180	330	345	210	120	445	
-8	1/2	160	160	275	275	210		415	
-10	5/8	130	130	250	250	210		350	
-12	3/4	105	105	215	215	210		350	420
-16	1	88	88	165	165	210		280	380
-20	1-1/4	63	63	125	125			210	350
-24	1-1/2	50	50	90	100				290
-32	2	40	40	80	90				250
-40	2-1/2	40		69					
-48	3			50					
-64	4								

## Hose selection chart

**How to use chart:** Locate the hose I.D. required and move to the right to the correct pressure. Then move up or down in this column for data on material, temperature, etc. to quickly determine whether the hose meets your requirements.

For complete information on any hose refer to hose catalog page number.

Core hoses are indicated with icons:



Standard hose selection chart								
	Core spiral hose	Spiral hose	Core suction hose	Braided textile hoses			Speciality hose	
Hose	EC420	EC615	WH004	WH005	WH006	WH007	EC330	
Page	72	73	74	75	76	77	78	
Usage								
	Suitable for use in hydraulic systems with high peak pressures and arduous operating conditions.	High pressure hydraulic systems with constant high working pressure for use with petroleum based fluids.	Suitable for use in suction applications for hydraulics, crude fuel, lubricating oils, gasoline, air, water and chemical transfer.	For hydraulic control lines; hydraulic systems service with petroleum and water-based fluids for low pressure industrial service.	For hydraulic control lines; hydraulic systems service with petroleum and water-based fluids for low pressure industrial service.	For hydraulic control lines; hydraulic systems service with petroleum and water-based fluids for low pressure industrial service.	An unique three wire braided hose that is capable to replace 4SP hoses in some applications.	
<b>Certifications</b>								
EN	EN856 R13	EN 856 R13		EN 854 1TE	EN 854 2TE	EN 854 3TE		
ISO	ISO 18752	ISO 18752						
SAE	SAE 100R13	SAE 100R15	SAE 100R4	SAE 100R6	SAE 100R6			
OTHER	DNV USCG MSHA	DNV MSHA	MSHA	MSHA	MSHA	MSHA	MSHA	
<b>Hose Specifications</b>								
Temp Range	-40° to 121° C -40° to 250° F	-40° to 121° C -40° to 250° F	-40° to 100° C -40° to 212° F	-40° to 100° C -40° to 212° F	-40° to 100° C -40° to 212° F	-40° to 100° C -40° to 212° F	-40° to 100° C -40° to 212° F	
Fittings	4S Series 6S Series	4S Series 6S Series	1A Series 1G Series, 2 pc Winner	2 pc Winner	2 pc Winner	2 pc Winner	1T Series 4S Series 2 pc Winner	
<b>Hose Construction</b>								
Inner Tubes	Synthetic rubber	Synthetic rubber	Oil-resistant NBR	Synthetic rubber	Synthetic rubber	Synthetic rubber	Synthetic rubber	
Reinforcement	4 wire spiral or 6 wire spiral	4 wire spiral or 6 wire spiral	2 fiber ply with helical wire	1 textile braid	1 textile braid	2 textile braid	3 wire braid	
Cover	Synthetic rubber	Synthetic rubber	Synthetic rubber	Synthetic rubber	Synthetic rubber	Synthetic rubber	Synthetic rubber	
<b>Maximum operating pressure (PSI)</b>								
DASH	HOSE ID	EC420	EC615	WH004	WH005	WH006	WH007	EC330
-4	1/4				28	75	145	
-6	3/8				28	63	110	445
-8	1/2				28	58	93	415
-10	5/8				24	50	80	350
-12	3/4	350		21	21	45	70	350
-16	1	350	420	17	20	40	55	
-20	1-1/4	350	420	14			45	
-24	1-1/2	350	420	10.5				
-32	2	350	420	7				
-40	2-1/2			4				
-48	3			4				
-64	4							

# Hose selection worksheet

Danfoss recommends using the **STAMPED** process to aid in determining the correct hose and coupling for your application. This worksheet is designed to help you organize information for determining the best hose for a given application. The questions are based on the hose selection factors described in this guide.

When selecting a hose, always use this worksheet in conjunction with this guide. Read all instructions concerning the hose you are selecting. If any questions arise contact Danfoss technical support at: [DPS\\_FC\\_EMEA\\_TechSupport@danfoss.com](mailto:DPS_FC_EMEA_TechSupport@danfoss.com)

## STAMPED

### S - Size

(I.D., O.D. and length)

### T - Temperature of

material conveyed and environmental

### A - Application,

the conditions of use

### M - Material being

conveyed, type and concentration

### P - Pressure to which

the assembly will be exposed

### E - Ends; style, type,

orientation, attachment methods, etc.

### D - Delivery testing,

quality, packaging, and delivery requirements

Flow (m<sup>3</sup> per minute) requirements? \_\_\_\_\_

Hose I.D. requirements given the flow requirements? \_\_\_\_\_

Pressure drop? \_\_\_\_\_

Length requirements (excluding hose ends)? \_\_\_\_\_

Temperature range of material to be transferred?

Min. \_\_\_\_\_ Max. \_\_\_\_\_ Average \_\_\_\_\_

Year-round external environment temperature range? \_\_\_\_\_

Cleaning temperature? \_\_\_\_\_

If the application is new, what service is to be performed?

\_\_\_\_\_

Internal and external environment consideration. Internal environment relates to the material being conveyed. External environment relates to anything originating from outside the hose.

Check all that apply.

Abrasive materials (conveyants and external)

Ozone

Petroleum products (aromatics, aliphatics, etc)

Acids/caustics

Materials that could cut or gouge hose

Animal fats (oils)

Solvents

Sparking or flames

Cleaning with steam

Material to be transferred? \_\_\_\_\_

Material concentration (%)? \_\_\_\_\_

What hose cleaning solution(s) will be used? \_\_\_\_\_

If you have any questions, please contact Danfoss Technical Support at: [DPS\\_FC\\_EMEA\\_TechSupport@danfoss.com](mailto:DPS_FC_EMEA_TechSupport@danfoss.com)



STAMPED Hose selection worksheet

What working pressure is required? \_\_\_\_\_

Are pressure surges involved in this application? How high? \_\_\_\_\_

What safety factor is required? \_\_\_\_\_

Is this a suction application? What vacuum rating is required? \_\_\_\_\_

End \_\_\_\_\_

Material \_\_\_\_\_

Attachment Method \_\_\_\_\_

Qty. required \_\_\_\_\_ Date required \_\_\_\_\_ Pkg. requirements \_\_\_\_\_

Testing Required -  No  Yes If Yes, Type: \_\_\_\_\_

Certification Required -  No  Yes If Yes, Type: \_\_\_\_\_

Will the selected hose need to possess any of the following features:

Branding information needed on the hose? \_\_\_\_\_

Color coding? \_\_\_\_\_

Any special designations required by agencies or associations? \_\_\_\_\_

Will any regulatory agency approvals be required? If yes, which one(s)? \_\_\_\_\_

Non-conductive rubber needed to prevent transmittal of electricity? \_\_\_\_\_

Static wire or static-dissipating tube to prevent static electricity buildup and discharge sparks? \_\_\_\_\_

Pin-pricked cover to resist blistering when transferring hot materials or air/gases under pressure? \_\_\_\_\_

Abrasion sleeve or guard? \_\_\_\_\_

Heat shield? \_\_\_\_\_

Sub-zero exposure resistance? \_\_\_\_\_

Special assembly requirements? \_\_\_\_\_

Continuous transfer service or intermittent service? \_\_\_\_\_

Flexibility: Do space restrictions exist where the hose will be used? \_\_\_\_\_

Bend Radius: of the hose relative to space in which hose will be used? \_\_\_\_\_

Considering the intended use of the hose, how flexible will it need to be (check one)?

Extremely flexible       Slightly flexible       Not an issue

Weight: How will the hose be handled during use, if all? \_\_\_\_\_

How important is the weight of the hose going to be in this application (check one)?

Very important       Slightly important       Not an issue

## Danfoss Tech Center

Where innovation and technology meet



### Application engineering

A Product Applications Engineer is responsible for performing a wide variety of engineering and technical tasks. They review all customer product specifications, including drawings, contracts, and project details. They are the main technical resources throughout the sales process. The Product Applications Engineer identifies and designs complex products and solutions, determining manufacturing feasibility and costs for specific customer applications and quotations.

### Engineering lab

The Engineering Lab is a place of learning and discovery for our technical team. This area includes our current crimp machine line up where we can build test samples and prove out new products and tooling on our crimp equipment. It also includes two of our 3D printers that we use for rapid prototypes, proving designs and developing new methods of manufacturing components. There is also space to perform product tear downs, review and analysis as well as machining capabilities for custom tooling, fixtures and cutaways.

### Environmental room

Fluid Conveyance Products are exposed to many harsh environments and we need to be able to duplicate some of these conditions. Environmental chambers are machines we use to simulate extreme temperature, humidity, vibration, flexing and pressurization conditions. The environmental room is filled with six environmental chambers with varying capabilities. While all the chambers can be programmed with a high/low temperature profile, two of the chambers have vibration capabilities, one has a mechanical flex capability and two

have humidity capabilities. Environmental testing is performed to either industry specifications, customer specifications or internally developed test protocols. As an added feature, a power unit can be brought to the chambers to perform impulse testing while at varying environmental conditions.

### Hydraulics lab

Our ISO/TS 16949 approved and A2LA certified Test Lab provides a suitable environment to conduct laboratory testing in support of new product development, ongoing customer support and internal continuous improvement activities. Our staff includes experienced Technicians, Hydraulics Systems experts, Electrical expertise, LabView expertise, in house Gauging and Calibration, Quality and Maintenance. We are fully capable of designing and developing all our test equipment from simple test fixtures to complex impulse machines.

### Impulse lab

The machines within this area are designed to perform the core hose tests of impulse and burst. Impulse testing is a fatigue test where hose is repeatedly exposed to high pressure pulses for a high number of cycles while at its highest operating temperature and smallest bend radius. These extreme conditions ensure hoses meet endurance requirements. Burst is a one time pressure test where hose is taken to failure and required to meet a 4 to 1 safety factor. Other testing that takes place in this area includes vibration, tensile, volumetric expansion and air brake flex testing. While not as common as burst and impulse, these tests are needed to support the vast array of industries that the Fluid Conveyance product lines serve.

### Material science lab

The Maumee, USA and Cerkezkoy, Türkiye Materials Science laboratory offers the formulation development of novel thermoset and thermoplastic elastomers alongside expertise in testing, chemical compatibility and QC analysis..

### Oven room

The ovens that occupy most of this room's floor space are utilized for a variety of high temperature tests including high temperature aging, hot oil circulation, high temperature impulse and high temperature burst. Testing to these protocols ensures our products will perform even when run at their extreme rated operating temperatures.

Abrasion to a hose cover will expose the steel reinforcement wires causing corrosion and eventually hose failure. The Fluid Conveyance product group offers a variety of hose covers from entry level low abrasion resistance to premium products that offer very high abrasion resistance. To characterize the abrasion resistance of a hose cover, we use an abrasion tester designed to run testing per ISO-6945. Salt spray is another standardized test protocol run in this room to test plating corrosion resistance. Plating is a significant factor for Fluid Conveyance because most of our fitting and adapter product lines are Zinc plated steel.

### Pilot plant

The Maumee, USA and Cerkezkoy, Türkiye Pilot Plant generates prototype hose based on engineering specifications and used in the Concept Assessment and Design Suitability stages of development.

# Danfoss term **glossary**

## Danfoss brand definitions

### Aeroquip®

Premium brand hose

### AQP™ High-Temp

Used exclusively for Aeroquip high-temp hose; constructed with patented elastomer materials.

### Bruiser®

Ultra-**abrasion** resistant hose cover; 100x greater abrasion resistance than the ISO 6945 industry standard

### Dura-Kote®

Plating technology offering three times the **corrosion protection** on carbon steel fittings, compared to competitive hose fittings – up to 1000 hours of corrosion protection. Used on premium fitting series such as 1A, Z and 4S/6S series.

### Dura-Pulse®

A patented **inner-tube** compound providing five times longer life than standard 2SC hoses. It is slow to age and has a low compression set, which provides better sealing and leak free performance.

### Dura-Seal™

Patented innovation that eliminates the hose assembly **cool-down leakage**, while extending hose assembly life and reducing equipment downtime.

### Dura-Tuff®

Premium **abrasion**-resistant hose cover; marketed as 8x greater than the ISO 6945 industry standard

### Dynamax®

Ultra-performance, premium hose offering **high pressure capabilities** with extended life and 50% better **bend radius** than EN standard.

### Hi-Pac®

Special braided hose construction type. FC310 and FC510 are examples. Additional wire is added into the braided reinforcement to allow for higher pressures. Mining hose.

### Lifesense®

A monitoring system that detects impending hydraulic hose failure and alerts operators and maintenance crews so they can schedule maintenance and plan downtime. The system continuously monitors hose condition via electrical signals and generates an alert when the hose starts to experience internal fatigue.

### MatchMate®

System that matches hose to fittings.  
Braided-Match number of rings (O) on layline with number of rings on fitting  
Spiral-Match either 4S or 6S on layline with corresponding mark on fitting

Braided & Spiral-Match hose dash size with size on fitting

### ORS®

Specialized fitting that provides an o-ring seal at the face of the fitting designed to eliminate leaks in high pressure systems.

### Winner™

Standard tier brand hose & fittings

### X-Flex®

Spiral hose offering 50% of SAE R13/R15 **bend radius** in demanding **high impulse** applications

## Fitting definitions

### 1A Aeroquip fitting series (TTC)

Aeroquip one-piece fitting series' name for core, braided hose products. It corresponds with the printing on both the hose layline and fitting. "Through the cover" (TTC) is a legacy series' name. Suitable for use on premium and standard products.

### 1G fitting series (OTC)

Premium series' name for "over-the-cover" (OTC) style fitting.

### 1R/2R reusable fitting series

Premium reusable fitting series' name for one and two-wire braided hose products. Suitable for use on premium and standard products.

### 1W fitting series

Premium internal skive, two-piece fitting series' name for select core spiral hoses used to achieve a higher level of performance. Suitable for use on premium and standard products.

### 4S/6S fitting series

Premium one-piece fitting series' name for core spiral hose products. Suitable for use on premium and standard products.

### STC® (snap to connect) series

High pressure fitting series' that makes hose line connection quick and easy, without the need for assembly tools.

### Winner one-piece fitting series

Standard tier fitting series. Does not use dura-kote plating technology. Suitable for use on standard products and selectively on premium products.

### Winner two-piece fitting series

Non-skive standard tier fitting series. Does not use Dura-Kote plating technology. Suitable for use on standard products and selectively on premium products.

## Industry terms

### Crimp fittings

A term used to describe non-reusable fitting component parts or complete assemblies for braided and spiral hoses. Core series are: 1S, 1A, 1B, 1G, 4S and 6S.

### Field attachable fitting

A fitting designed to be attached to a hose without crimping or swaging. This fitting is not always a reusable type fitting.

### Hose fittings

A device attached to the end of the hose to facilitate connection. "Hose-end" and "coupling" are equivalent terms in the industry.

### Maximum working pressure

The maximum pressure for which the hose assembly is designed. Note: "operating pressure" is an equivalent term but should not be used in copy.

### Nipple

The portion of the fitting that goes directly into the inner diameter of the inner tube of the hose. It extends out of the hose and into the connecting end. Also known in the industry as a "stem" or "insert".

### Non-skive

Refers to hose and fitting combinations that does not require removing part of the hydraulic hose cover and/or inner tube prior to attaching fittings. Also known in the industry as "no-skive".

### Socket

The portion of a fitting that is compressed by crimping to seal the hose onto the fitting barbs and create a permanent attachment. Also known as "collar" and "ferrule" in the industry.

## Key fluid conveyance terms

### One wire braided hose

Hose series reinforced with a single steel braid

### Two wire braided hose

Hose series reinforced with two steel braids

### Four wire spiral hose

Hose series reinforced with four wires

### Six wire spiral hose

Hose Series reinforced with six wires

### Abrasion hose

Defines the level of abrasion-resistance a cover offers. Danfoss has three levels: standard, premium (Dura-Tuff) and ultra (Bruiser)

### High-temp hose

Danfoss' designated term for premium core products with a max temperature rating of at least 150°C (300°F).

### Low-temp hose

Danfoss' designated term for premium core products with a max temperature rating of at least -57°C (-70°F).

### Premium tier

Products that **exceed** industry specifications. For Danfoss, distinctions from standard tier are made with abrasion resistance, temperature range, impulse cycles and ISO 18752 rating.

### Standard tier

Products that **meet** industry specifications.

### Specialty hose

Active products that tend to be used for more niche applications.



# Danfoss PowerSource™

Your information headquarters

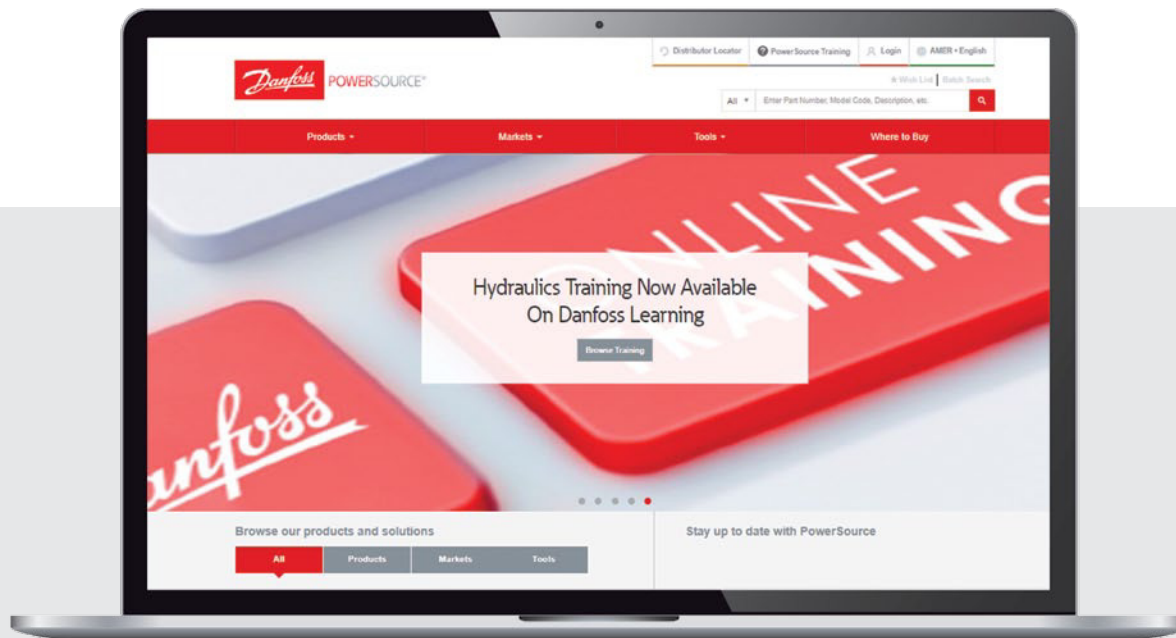

Putting fluid conveyance information at your **fingertips.**

**Danfoss PowerSource™ is the hub for all of Fluid Conveyance. This informational site houses Danfoss's product, market and technical information including:**

- |  |  |
|--|--|
| <ol style="list-style-type: none"> <li>1. Searchable fluid conveyance product information:             <ul style="list-style-type: none"> <li>• Part numbers</li> <li>• Sizes</li> <li>• Performance and specifications</li> <li>• Branding information</li> </ul> </li> <li>2. Literature and videos</li> <li>3. Product value propositions</li> <li>4. Crimp specifications</li> </ol> | <ol style="list-style-type: none"> <li>5. 2D/3D cad models</li> <li>6. Hose assembly configurator</li> <li>7. Marketplace (authenticated PowerSource only)</li> <li>8. List prices and Lead times (authenticated Powersource users)</li> </ol> |
|--|--|
- To access these tools and more, visit and log in to PowerSource from <https://powersource.danfoss.com/> and then select tools.

# Crimp specs **in a flash!**

Find your crimp specs quickly and easily with the PowerSource Crimp Spec tool. You can create a custom crimp chart from your desktop following these simple steps.

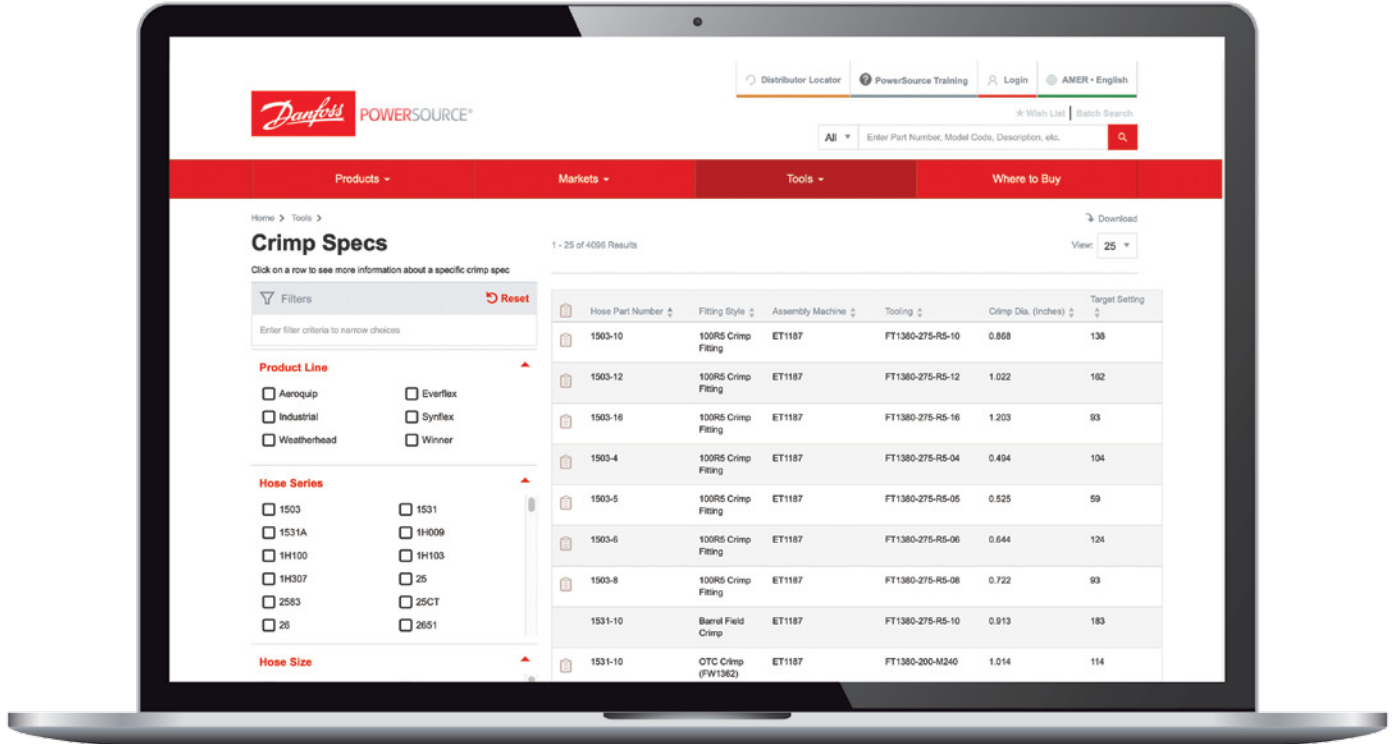

1. Go to PowerSource	2. Enter criteria	3. Download
<p>Visit Crimp Specs at <a href="http://danfoss.com/crimp">danfoss.com/crimp</a></p>	<p>Select your crimp spec criteria. This includes Assembly Machine(s), Product Line, Hose Series, Hose Size, and Fitting Style.</p>	<p>Locate the download icon at the top right of the screen and select either the PDF or Excel option to generate your custom chart.</p> <p>*Excel format allows you to perform custom sorting, filter data, remove unneeded fields, and to add custom notes and color coding.</p>

## Crimp specs **on the go!**

Danfoss’s mobile crimp spec tool provides a four-step guided selection process for quick access to crimp specs on your mobile device.

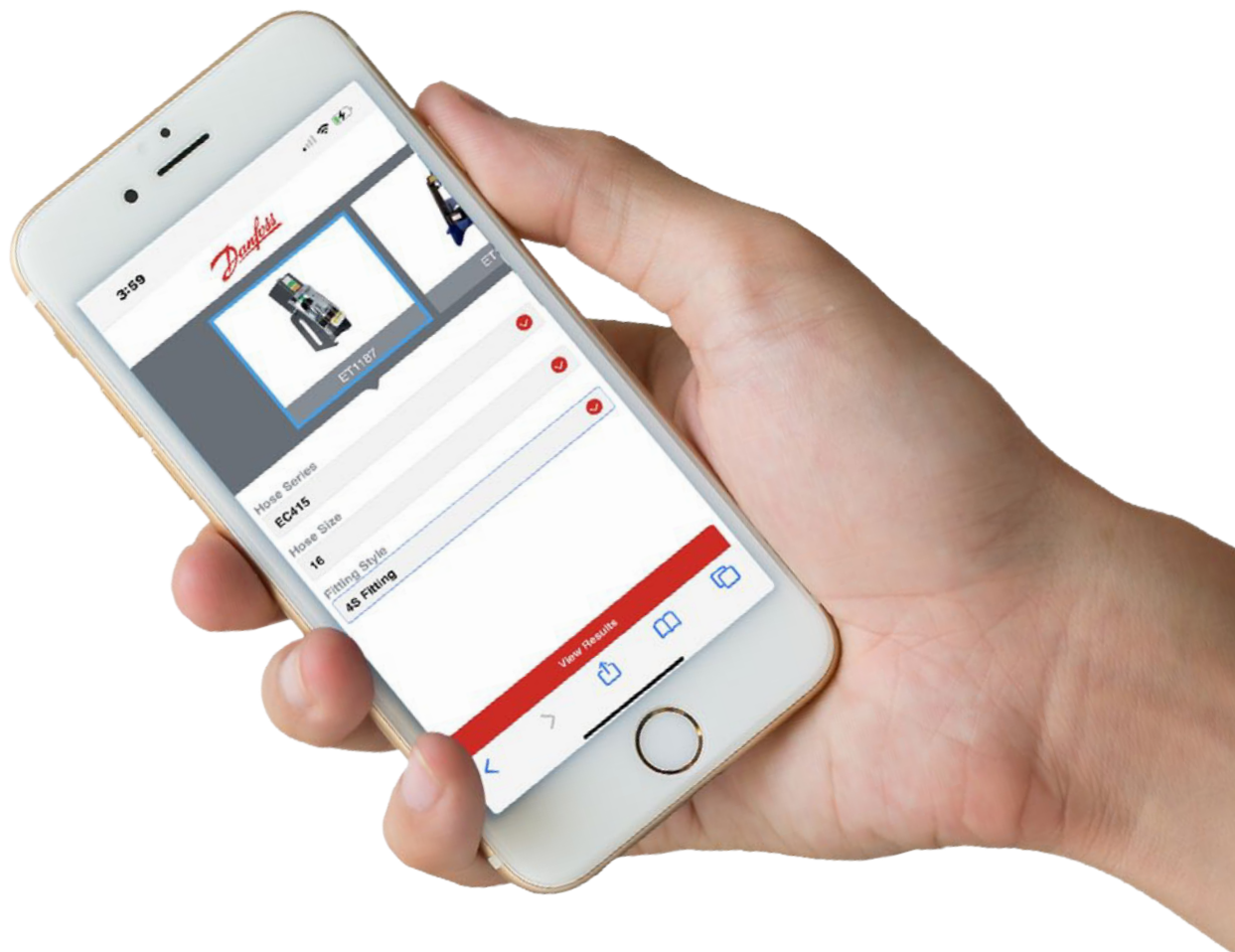

### **It's as easy as:**

Visit Crimp Specs [danfoss.com/crimp](http://danfoss.com/crimp) on your mobile device

- Find your machine
- Select your hose series
- Select your hose size
- Find your fitting style





**Get results, fast!** You can even bookmark the crimp spec page and add it as an app on the home screen of your mobile device for easy access at any time!

**For iOS,** open the webpage in Safari, click the boxed arrow icon at the bottom of the screen, and select the plus sign icon “Add to Home Screen.”

**For Android,** open the webpage, click the three vertical dots on the top right hand corner, and select “Add to Home Screen.”

# Standard and premium fittings - **the right product for every application**

Braided or spiral, premium or standard, there is a Danfoss fitting designed for your application.

Braided Hose Fittings	Features:
<p><b>Premium</b> 1A/1G</p> 	<ul style="list-style-type: none"> <li>• New <b>Dura-Kote™</b> plating technology for up to 1,000 hours of corrosion resistance</li> <li>• Bite the wire technology for best in class connection and sealing</li> <li>• Class zero leakage SAE J1176 on approved hose styles</li> <li>• Danfoss' <b>MatchMate®</b> program provides identification markings on the hose, hose fittings, and crimp dies for quick and easy assembly</li> </ul>
<p><b>Standard</b> Two-piece Winner</p> 	<ul style="list-style-type: none"> <li>• Non-skive, two-piece crimp fitting</li> <li>• One nipple part number for EC115, EC215, EC110, EC210, EC118, EC082, WH004, WH005, WH006, WH007, EC426, EC330 standard hoses</li> <li>• Meets industry specifications when used with the EC115, EC215, EC110, EC210, EC118, EC082, WH004, WH005, WH006, WH007, EC426, EC330 standard hoses</li> <li>• Clear silver hexavalent chromium-free plating</li> <li>• Carbon steel material</li> </ul>
Spiral Hose Fittings	Features:
<p><b>Premium</b> 4S/6S/1W Spiral Series</p> 	<ul style="list-style-type: none"> <li>• New <b>Dura-Kote</b> plating technology for up to 1,000 hours of corrosion resistance</li> <li>• New patent pending <b>Dura-Seal™</b> technology to eliminate hose assembly cool-down leakage</li> <li>• Class zero leakage SAE J1176 on approved hose styles</li> <li>• Danfoss' <b>MatchMate</b> spiral-hose/fitting identification system provides identification markings on the hose, hose fittings, and crimp dies for quick and easy assembly</li> </ul>
Reusable Hose Fittings	Features:
<p><b>Premium</b> Reusable</p> 	<ul style="list-style-type: none"> <li>• New <b>Dura-Kote</b> plating technology for up to 1,000 hours of corrosion resistance</li> <li>• Engineered to provide peak performance with Danfoss' core braided hose products</li> <li>• Can be assembled in the field without special tooling</li> <li>• Reduced downtime</li> <li>• Quick repair</li> </ul>



## Dura-Kote and Dura-Seal technology extends the life of your hose assembly



**3X** Carbon Steel Corrosion Protection

### Dura-Kote Plating Technology

Hose fittings that will now offer 3x the corrosion protection on carbon steel fittings as compared to competitive hose fittings. Danfoss' Dura-Kote fittings provide up to 1000 hours of corrosion protection. This is a huge step forward in metal fitting corrosion protection. (Aeroquip fittings only)



4S/6S Fitting

**Class 0** Cool-Down Leakage Protection

### Dura-Seal™ Technology

This patent-pending innovation from Danfoss eliminates hose assembly cool-down leakage, while extending hose assembly life, reducing equipment down-time. (Aeroquip fittings only)

## Need **Metric or Imperial?**

Danfoss has the answer.

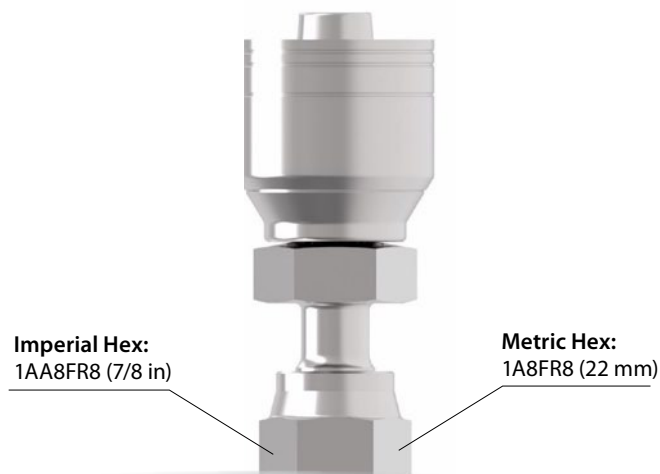
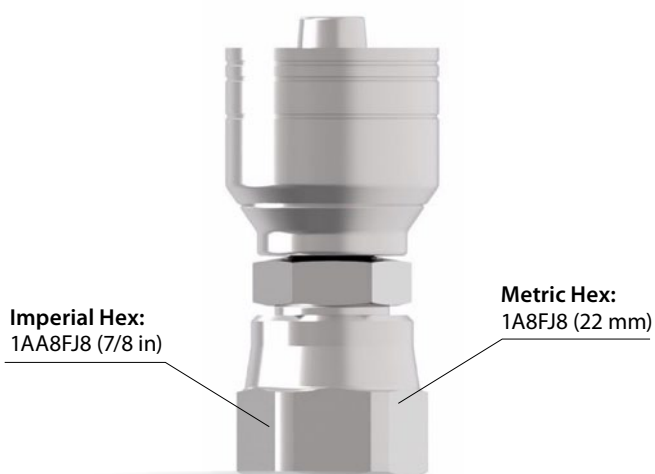

### Available imperial fitting configurations\*:

- JIC
- ORS
- Many metric FJ and FR fittings have an imperial equivalent

\*Danfoss imperial fittings are not listed in this catalog, please contact customer service for more information.

Knowledge is power,  
**invest in your career!**

Danfoss fluid conveyance training

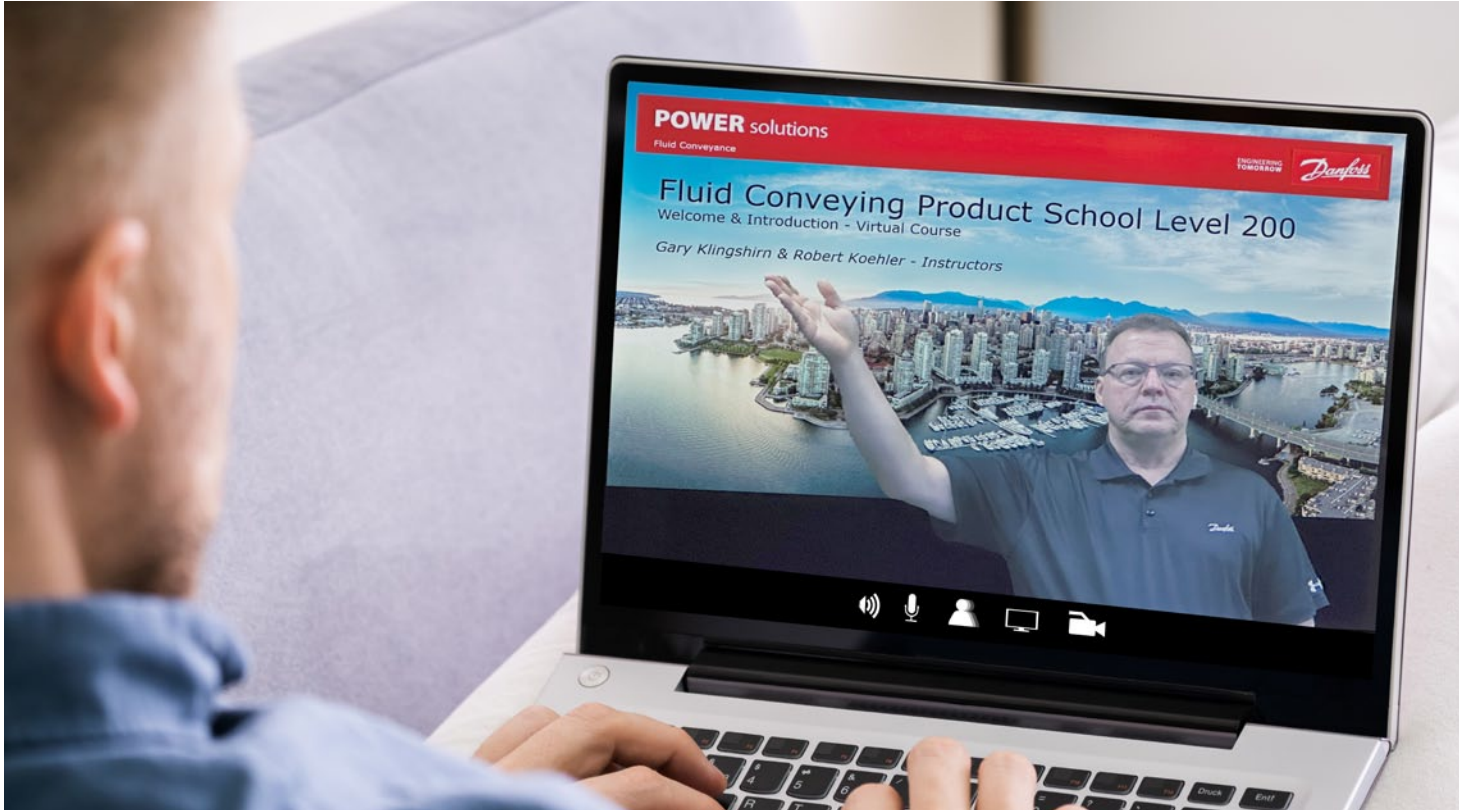

Master Danfoss's core fluid conveyance products and more with the help of our training team! Danfoss offers in depth, formal training courses designed to make you an expert in the field.

Attend Danfoss's 200 Level Fluid Conveying Products School to learn more about general product and application information or Danfoss' 300 and 400 Level Fluid Conveying Products Specialist School for a class focused on more technical information as well as competitive advantage materials.

Check out <https://www.danfoss.com/en/service-and-support/learning/dps-learning-and-training-solutions/> for specific product courses and dates. Contact [hydraulicstraining@Danfoss.com](mailto:hydraulicstraining@Danfoss.com) for further details.

**Danfoss hydraulics training center**

Nordborgvej 81,  
6430 Nordborg, Denmark  
Phone toll free: 1-800-413-8809  
Fax: (952) 906-3731

[HydraulicsTraining@Danfoss.com](mailto:HydraulicsTraining@Danfoss.com)

# UniqID™ Asset Tracker

Small label. Big Impact.



The Danfoss UniqID asset management solution seamlessly drives new efficiencies into every aspect of the asset lifecycle—from asset tracking, to routinized maintenance alerts, replacement orders and more. Through the use of an intuitive six-digit coding system and cloud-based portal—UniqID asset tracker makes it easy to label, track and replace hose assemblies.



To get started, contact [UniqID@Danfoss.com](mailto:UniqID@Danfoss.com) or visit [Danfoss.com/UniqID](http://Danfoss.com/UniqID)

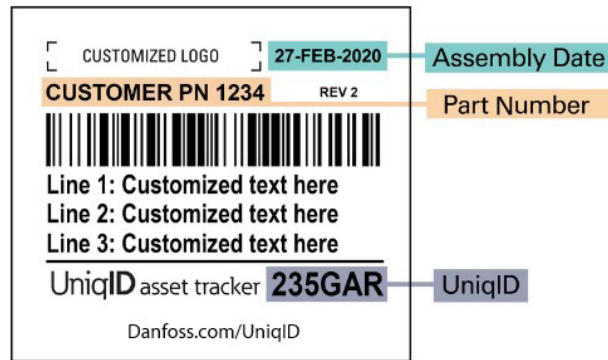

Label	Replace	Track	Assemble
<p><b>Drive aftermarket sales</b> Via the UniqID code or label branding</p> <hr/> <p><b>Grow your business</b> Offer services to set yourself apart from the competition</p> <hr/> <p><b>Prevent attrition</b> Provide shared asset management information with key accounts</p>	<p><b>Increase uptime</b> With proactive maintenance capabilities</p> <hr/> <p><b>Reduce downtime</b> Order replacements without ever bringing in a hose assembly</p> <hr/> <p><b>Reduce fines</b> By having critical documentation easy to find electronically</p>	<p><b>Eliminate paper</b> With a web-based platform</p> <hr/> <p><b>Proactive inspection and replacement</b> Cyclical approach to maintenance, increasing sales potential</p> <hr/> <p><b>Improve decision making</b> With product lifecycle analysis tools</p> <hr/> <p><b>Manage safety certificatio</b> With electronic attachment features</p>	<p><b>Save time</b> UniqID's bill of material feature takes the guesswork out of hose replacement</p> <hr/> <p><b>Reduce errors</b> Labels provide critical data at-a-glance</p> <hr/> <p><b>Increase efficiency</b> Leverage shared attachments; no time wasted searching paper trails</p>

Intelligent layline

Our laylines provide **vital hose data** instantly.

Engineering is complex. We made it easier.  
Get critical data at a glance with **Danfoss Intelligent Laylines**

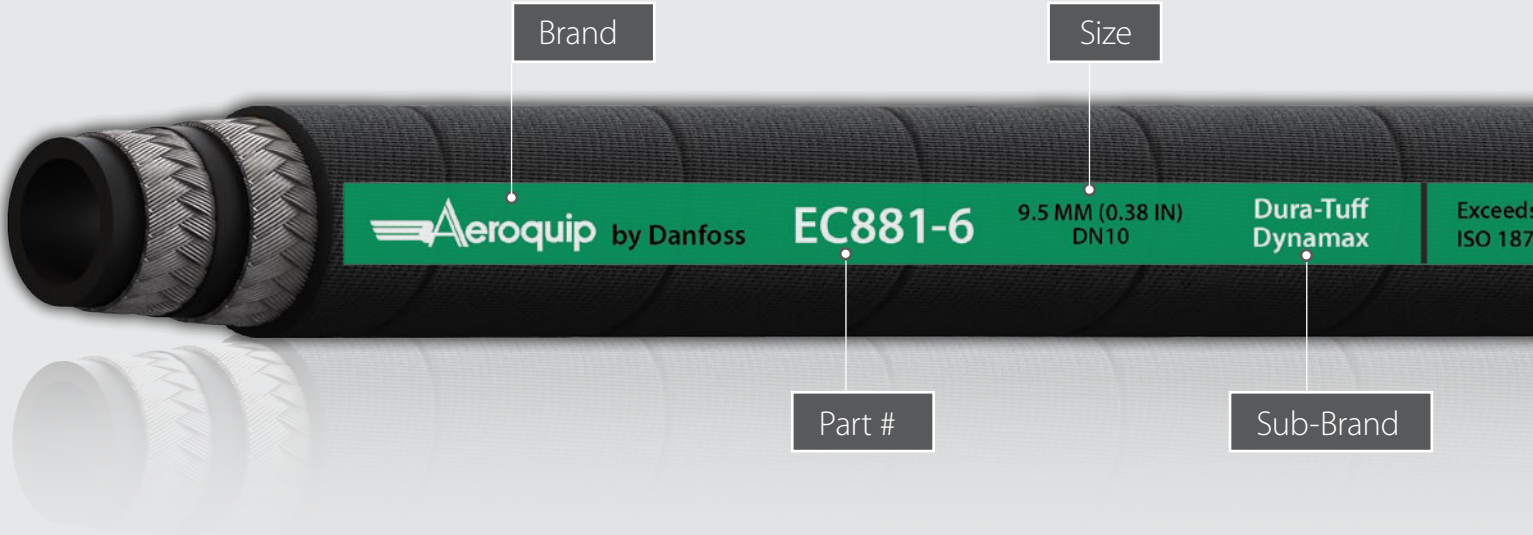

**Danfoss MatchMate® system:** Match fittings to hose with ease.

Braided

**Fitting Part Number:**

A 1A on the layline should pair with a 1A on the fitting part number.

**1 or 2-wire braid:**

One O on the layline will match with one ring on fitting designating 1-wire braided hose.

Double OO on layline will match with two rings on fitting designating 2-wire braided hose.

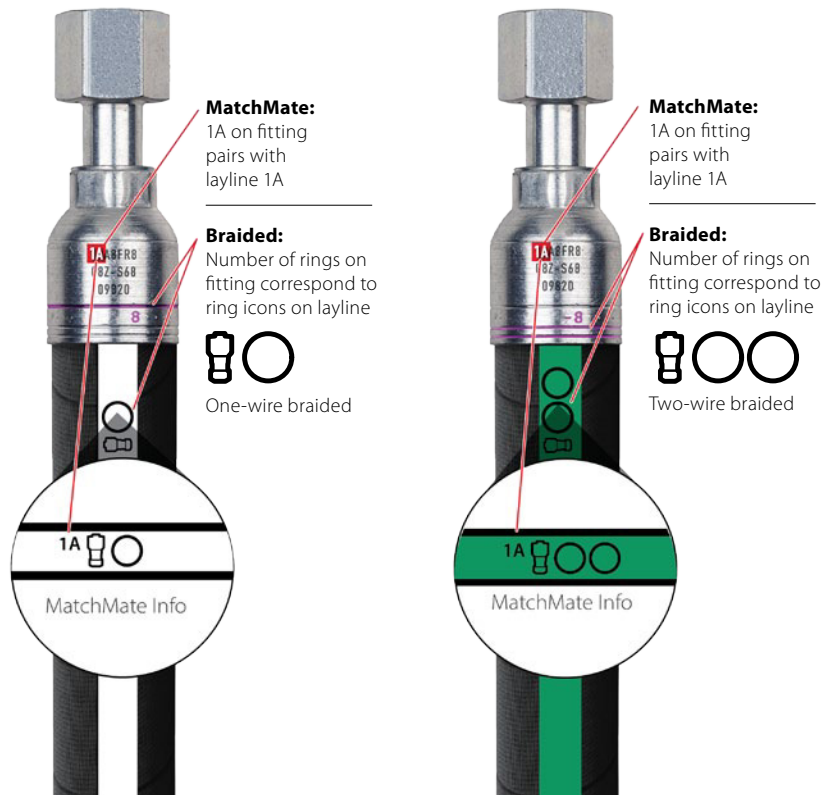



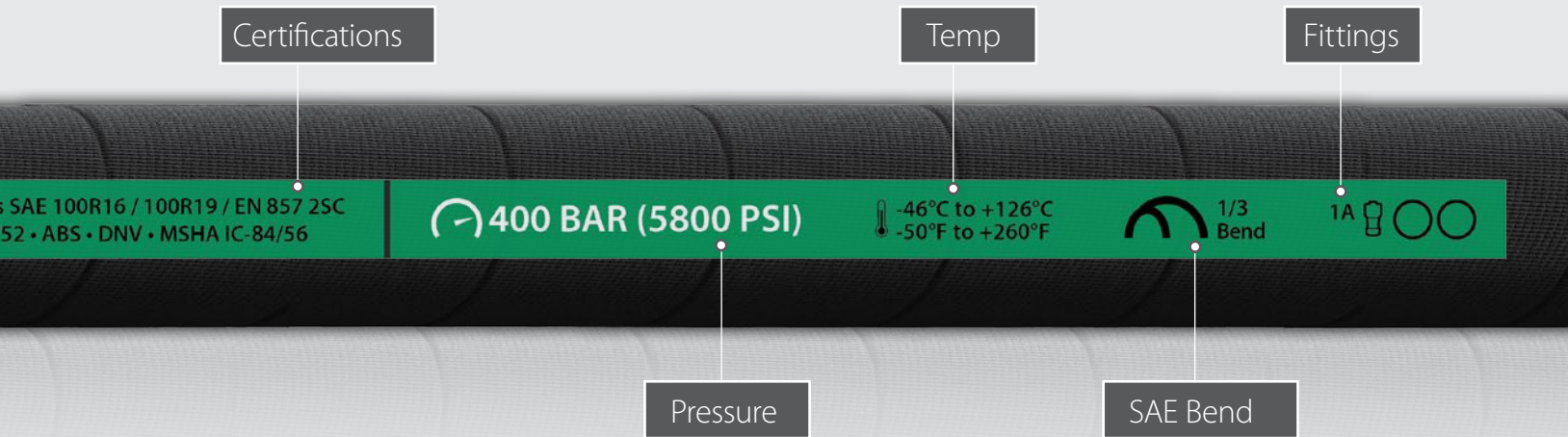

## Spiral

### Fitting Part Number:

A 4S or 6S on the layline should pair with a 4S or 6S on the fitting part number.

### 4 or 6 wire spiral

A 4S on layline should pair with four rings on fitting designating 4-wire spiral hose.

A 6S on layline will match with six rings on fitting designating 6-wire spiral hose.

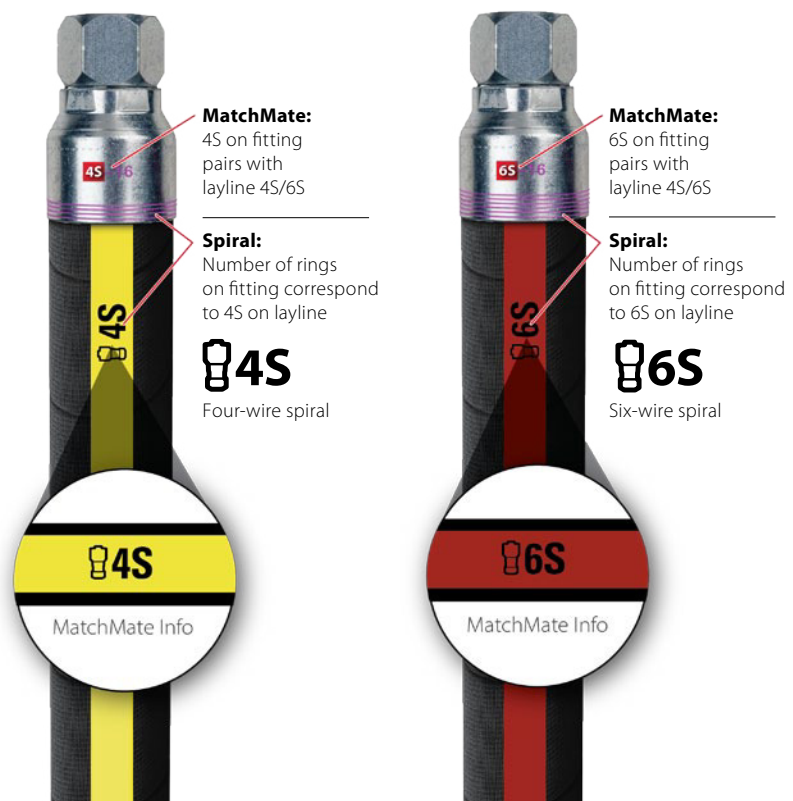



Two-tier product portfolio

From the ordinary to the extreme, Danfoss has a **solution that fits\***.



Premium



High-Temp



Low-Temp



Abrasion



Suction



Standard



**Premium and standard hydraulic hose options:**

**Premium:** Aeroquip by Danfoss

**Standard:** Winner by Danfoss





At Danfoss, we understand that hydraulic hose and fittings need to match the application, for the ultimate in performance and safety.

Because fluid conveyance platforms run the extreme, from low-pressure to high, moderate impulse to intense, from stable familiar environments to unforgiving conditions Danfoss Rubber Hydraulic Hose & Fittings provides options. The option to choose between standard-performance value based hose for less extreme environments and premium hoses developed for specific applications that push to the edge.

We do that for our customers, our partners. For those that put their trust in us. We don't compromise our standards and neither should you. When it comes to safety, technology and performance, we pledge our best, everyday.

---

\*All **core** premium and standard hoses in the catalog are designated with an icon highlighting premium, premium specialty or standard. See chart on following page for more information.

## Two-tier product portfolio

The Core Premium		Hose Specialty	Operating Temp	Abrasion Resistance	Bend Radius	Fluid Compatibility and Rubber Compounding	Impulse Cycles
<b>PREMIUM</b>		<b>Certifications:</b> SAE ABS EN MSHA ISO DNV Customer spec					
		 Premium	 High: Up to 126 °C Low: -40 °C	 Dura-Tuff® Cover (8x greater than standard)	 1/2 Bend	 Danfoss Premium	 Exceed Industry Standard
<b>HIGH-TEMP</b>		<b>Certifications:</b> SAE ABS EN MSHA Customer spec					
		 High-Temp	 High: 150 °C Low: -40 °C	 Dura-Tuff® Cover (8x greater than standard)	 Full Bend	 Danfoss Premium	 Exceed Industry Standard
<b>LOW-TEMP</b>		<b>Certifications:</b> SAE EN MSHA Customer spec					
		 Low-Temp	 High: 100 °C Low: -57 °C	 Dura-Tuff® Cover (8x greater than standard)	 1/2 Bend	 Danfoss Premium	 Exceed Industry Standard
<b>ABRASION</b>		<b>Certifications:</b> SAE ABS EN DNV Customer spec					
		 Abrasion	 High: 100 °C Low: -40 °C	 Bruiser Cover (700x greater than standard)	 1/2 Bend	 Danfoss Premium	 Exceed Industry Standard
<b>SUCTION</b>		<b>Certifications:</b> SAE ABS EN MSHA ISO DNV USCG					
		 Suction	 High: Up to 150 °C Low: -40 °C	 Standard Cover	 1/2 Bend	 Danfoss Premium	 Exceed Industry Standard
The Core Standard		Hose Specialty	Operating Temp	Abrasion Resistance	Bend Radius	Fluid Compatibility and Rubber Compounding	Impulse Cycles
<b>STANDARD</b>		<b>Certifications:</b> SAE EN MSHA Customer spec					
		 Standard	 High: 100 °C Low: -40 °C	 Standard Cover Standard Abrasion	 Full Bend	 Danfoss Standard	 Industry Standard

Premium & standard hydraulic hose.  
 Know the **difference.**

 <p>Premium</p>	 <p>High-Temp</p>	 <p>Low-Temp</p>	 <p>Abrasion</p>	 <p>Suction</p>	 <p>Standard</p>
--	--	---	---	--	---

**Premium**

Our core premium hoses for OEM or aftermarket use exceed industry standards for pressure, temperature and abrasion resistance, with options adapted to handle your toughest jobs.

**Standard**

Winner® by Danfoss hoses meet all industry standards for pressure, temperature and abrasion resistance, offering the right product at a competitive price point for OEM markets.

# Hose product page diagram

## Top hose section

**1 Core hose key**

**2 Part # and description**  
**GH681**  
 Core premium one wire braided hose

**3 Hose part number & hose classification**  
 Premium core hose  
 GH681

**4 Performance qualifications**  
 Meets or exceeds:  
 SAE 100R17 performance | EN 857 Type 1SC performance | ISO 1436 1SN | ISO 18752

**5 Layline**

**6 Hose construction image**

## Middle hose section

**7 Application and hose information**

**Typical application:**  
 Petroleum and fire-resistant hydraulic fluids, fuel and lubricating oils, gasoline, water and other industrial fluids

<b>Agency specifications:</b>	MSHA   ABS   DNV   USCG		
<b>Hose construction:</b>	<b>Inner Tube:</b> Nitrile	<b>Reinforcement:</b> One wire braid	<b>Cover:</b> Dura-Tuff Premium Abrasion
<b>Operating temperature:</b>	-46°C to +126°C (-50°F to +260°F)		
<b>Qualified fittings:</b>	1A Series 1R Series (-4, -6, -8, -12, -16)		

## Bottom hose section

**8 Part # and hose specs**

PART #	SIZE DIMENSIONS				PRESSURE				BEND		WEIGHT	
	Hose I.D.		Hose O.D. (nominal)		Working Pressure		Min. Burst Pressure		Min. Bend Radius		Weight	
	mm	in	mm	in	bar	psi	bar	psi	mm	in	kg/m	lbs/ft
<b>GH681-3</b>	4,8	0.19	10,9	0.42	250,0	3650	1000	14500	45,0	1.77	0,16	0.11
<b>GH681-4</b>	6,4	0.25	12,9	0.51	255,0	3700	1020	14800	50,0	1.97	0,21	0.14
<b>GH681-5</b>	7,9	0.31	14,0	0.55	225,0	3250	900	13000	55,0	2.17	0,22	0.15
<b>GH681-6</b>	9,5	0.38	16,3	0.64	235,0	3400	940	13600	63,0	2.48	0,31	0.21
<b>GH681-8</b>	12,7	0.50	19,9	0.78	221,0	3200	883	12800	90,0	3.54	0,43	0.29
<b>GH681-10</b>	15,9	0.63	22,3	0.88	140,0	2025	559	8100	100,0	3.94	0,44	0.29
<b>GH681-12</b>	19,0	0.75	26,0	1.02	138,0	2000	552	8000	120,0	4.72	0,56	0.37
<b>GH681-16</b>	25,4	1.00	34,0	1.34	103,0	1500	414	6000	150,0	5.91	0,84	0.56
<b>GH681-20</b>	31,8	1.25	41,5	1.63	69,0	1000	276	4000	210,0	8.27	1,01	0.68
<b>GH681-24</b>	38,1	1.50	47,9	1.89	52,0	750	207	3000	250,0	9.84	1,23	0.83
<b>GH681-32</b>	50,8	2.00	64,0	2.52	41,0	600	166	2400	315,0	12.4	2,01	1.32

## 9 Hose classification

Core | Premium | Standard | Braided | Spiral | High-Temp | Low-Temp | Abrasion | Suction

## Top hose section

### 1 Core hose key

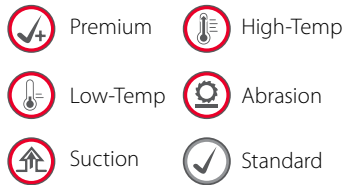

### 2 Part # & description

Hose part number and product description

### 3 Hose part number and hose classification

Corner key provides easy identification of hose name and premium, standard or core designation

### 4 Performance qualifications

Hose performance qualifications

- EN
- SAE
- ISO

### 5 Intelligent layline

Visual representation hose layline

### 6 Hose construction

Visual representation of hose construction

- One or two wire braid
- Four or six wire spiral
- Other

## Middle hose section

### 7 Application & hose info

Application info

- Agency specifications
  - MSHA
  - ABS
  - DNV
  - USCG
- Hose construction
  - Inner tube
  - Reinforcement
  - Cover
- Operating temperature
- Qualified fittings

## Bottom hose section

### 8 Part # and hose specs

Quickly locate hose part number, sizing, pressure rating, bend radius and weight in an easy to read chart

- Hose Part #
- Size (mm, in):
  - Hose I.D.
  - Hose O.D.
- Pressure (Bar/PSI)
  - Working Pressure
  - Burst Pressure
- Hose bend (mm/in)
- Weight (kg/m | lbs./ft.)

### 9 Easy hose classification

Easy hose reference identification located at the bottom of all hose part pages

- Core
- Premium
- Standard
- Spiral
- High-temp
- Low-temp
- Abrasion
- Suction



# Agency Listings

## Listed Standard and Industrial Agencies

<b>MSHA</b>	Mine Safety and Health Administration	<b>DIN</b>	Deutsches Institut für Normung	<b>UL</b>	Underwriters Laboratories
<b>USCG</b>	US Coast Guard	<b>EN</b>	Committee for European Normalization	<b>ISO</b>	International Standards Organization
<b>DNV</b>	DNV/Agency for Maritime Industry	<b>ABS</b>	American Bureau of Shipping	<b>BAAINBw</b>	Bundesamt für Ausrüstung, Informationstechnik und Nutzung der Bundeswehr
		<b>SAE</b>	Society of Automotive Engineers		

## ISO 18752 performance

Type	Temperature	Impulse Pressure <small>% of Max Working Pressure</small>	Minimum # of cycles
AC	212° F (100° C)	133%	200,000
BC	212° F (100° C)	133%	500,000
CC	250° F (120° C)	120 % / 133%	500,000
DC	250° F (120° C)	133%	1,000,000

## EN hose series

EN Hose Series	Description
1ST	1-wire braid - standard cover
1SN	1-wire braid - thin cover
2ST	2-wire braid - standard cover
2SN	2-wire braid - thin cover
4SP	4-wire spiral
4SH	High Pressure 4-wire spiral
1SC	Compact 1-wire braid
2SC	Compact 2-wire braid
1TE	1-textile braid
2TE	1-textile braid
3TE	2-textile braid

## SAE 100R hose series

SAE 100R Series	Description
100R1	Steel wire reinforced, rubber covered hydraulic hose (one wire braid)
100R2	High pressure, steel wire reinforced, rubber covered hydraulic hose (two wire braid)
100R3	Double fiber braid (non-metallic), rubber covered hydraulic hose
100R4	Wire inserted hydraulic suction hose
100R5	Single wire braid, textile covered hydraulic hose
100R6	Single fiber braid (non-metallic), rubber covered hydraulic hose
100R7	Thermoplastic hydraulic hose Black - conductive Orange - non-conductive
100R8	High pressure thermoplastic hydraulic hose Black - conductive Orange - non-conductive

SAE 100R Series	Description
100R12	Heavy duty, high impulse, four-spiral wire reinforced, rubber covered hydraulic hose Heavy duty, high impulse, multiple-spiral wire reinforced, rubber covered hydraulic hose
100R13	Heavy duty, high impulse, multiple-spiral wire reinforced, rubber covered hydraulic hose
100R14	Polytetrafluorethylene (PTFE)-lined hydraulic hose, single-stainless steel braid
100R15	Heavy duty, high impulse, multiple-spiral wire reinforced, rubber
100R16	Compact high pressure, one- and two-wire reinforced rubber covered hydraulic hose
100R17	Compact 21 MPa maximum operating pressure, one- and two-steel wire reinforced rubber covered hydraulic hose with smaller bend radius
100R19	Compact 28 MPa maximum operating pressure, one- and two-steel wire reinforced rubber covered hydraulic hose with smaller bend radius

Aeroquip by Danfoss

## Core premium and premium hose



Premium



High-Temp



Low-Temp



Abrasion



Suction

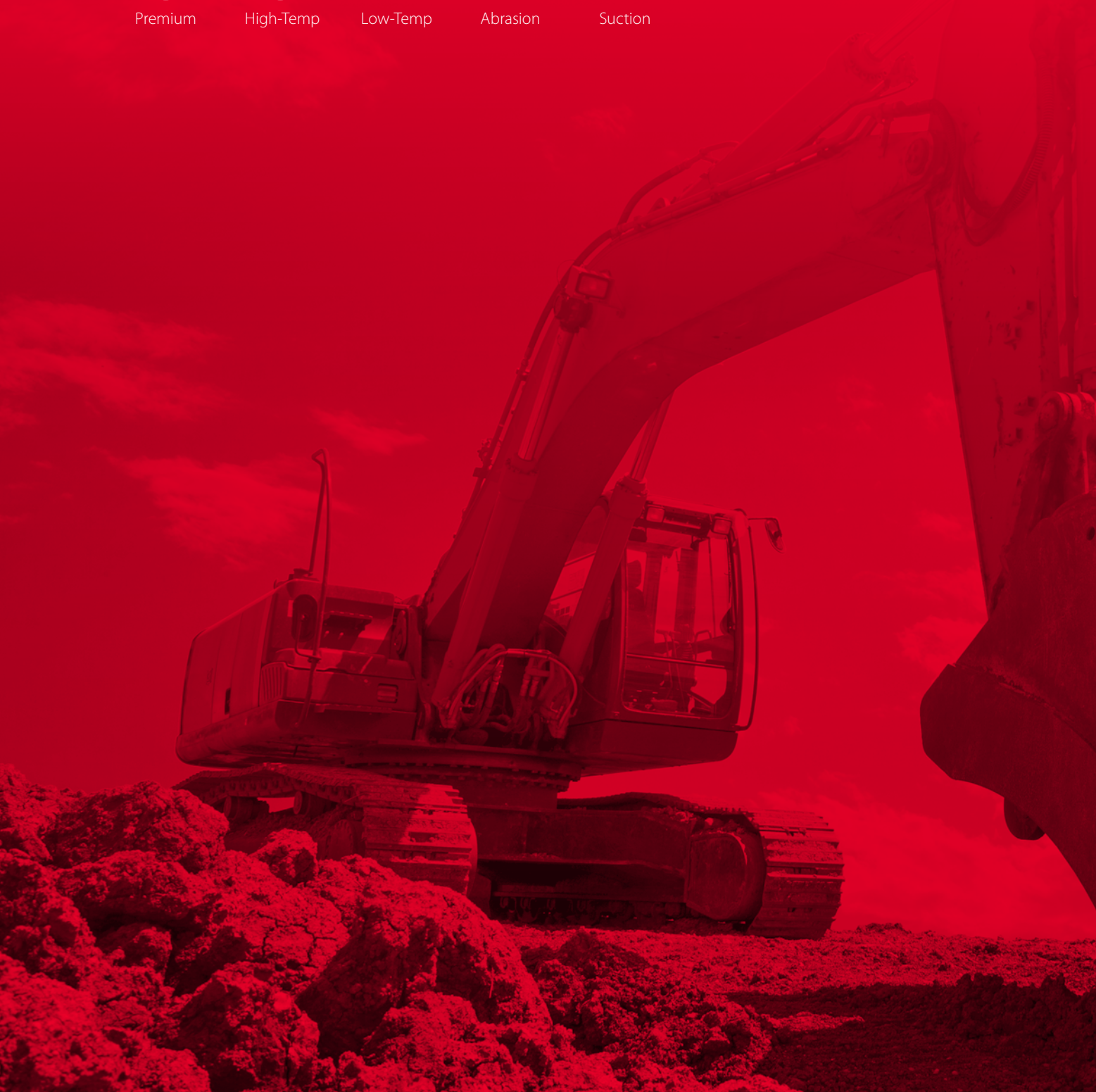

## Ordering information

# Ordering & hose numbering system

### How to order

Accurate processing and prompt delivery of your order depends on easy identification of your requirements. Please order Aeroquip and Winner brand parts using correct part numbers as described in this guide. Inquiries and orders should be directed to your distributor or:

**Danfoss Distribution II**  
 A/S Nordborgvej 81,  
 6430  
 Nordborg, Denmark  
[www.Danfoss.com/hydraulics](http://www.Danfoss.com/hydraulics)  
 Inside.Sales.DPS.EMEA@  
 danfoss.com

#### Part numbers and dash sizes

Dash size designates the nominal size in 16th of an inch. This number immediately follows the part number and is separated from it with a dash.

#### Dimensions

Dimensions given in this guide for Aeroquip and Winner products are approximate and should be used for reference only. Exact dimensional information for a given product is subject to change and varying tolerances;

contact Danfoss directly for full current information.

#### **WARNING**

##### Hose assemblies

Danfoss manufactures the terminal ends of our hose fittings to the appropriate requirements established by the SAE or DIN. Therefore, the performance ratings of these hose fittings meet the SAE or DIN requirements. It is possible to order a hose assembly with a fitting terminal end that has a

performance rating lower than the hose rating. When ordering hose assemblies, please keep the connecting end performance rating in mind since this may affect overall hose assembly performance. Hose assembly components (hose and fittings) are easily assembled in the field. However, factory assembled reusable and crimped hose assemblies are available. For complete information, contact Danfoss.

### Numbering system - hydraulic hose

Depending on the production type, hoses will be bundled in pre-defined hose lengths:

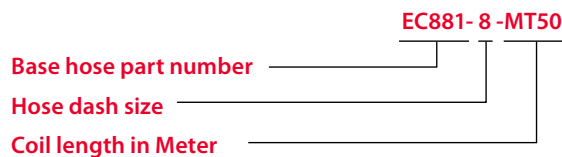

Danfoss is committed to providing pre-defined hose lengths with as few cuts as possible. Nevertheless, please note that following specifications will be valid for the bundled part numbers:

	< <b>MT61</b>	> <b>MT61</b>
<b>Max number of pieces in one bundled coil</b>	Max. 3 pieces	Max. 5 pieces
<b>Shortest length</b>	5 meter	5 meter
<b>Overall length tolerance</b>	+/- 1%	+/- 1%

# The premium hoses

Core hose

Core premium braided hoses		Core premium spiral hoses		Premium braided speciality hoses	
Hose	Page	Hose	Page	Hose	Page
<b>GH681</b> Core premium one wire braided hose	36 	<b>FC500</b> Core premium X-Flex® four and six wire spiral hose	45 	<b>GH585</b> Premium one textile braided hose	53
<b>FC510</b> Core premium AQP™ high-temp HI-PAC one wire braided hose	37 	<b>GH466</b> Core premium six wire spiral hose	46 	<b>FC310</b> Premium Hi-Pac mining one wire braided hose	54
<b>GH781</b> Core premium two wire braided hose	38 	<b>EC600</b> Core premium X-Flex® four and six wire spiral hose	47 	<b>SH222</b> Premium Hi-Pac mining two wire braided hose	55
<b>EC881</b> Core premium Dynamax ultra- performance two wire braided hose	39 	<b>EC850</b> Core Dynamax ultra-performance four and six wire spiral hose	48 	<b>Premium spiral speciality hoses</b>	
<b>GH195</b> Core premium AQP high-temp two wire braided hose	40 	<b>EC525</b> Core premium AQP high-temp four wire spiral hose	49 	<b>GH507</b> Premium heavy wire four spiral hose	56 
<b>GH120</b> Core premium low-temp two wire braided hose	41 	<b>EC810</b> Core premium low-temp four and six wire spiral hose	50 	<b>GH435</b> Premium phosphate-ester four wire spiral hose	57 
<b>Core premium spiral hoses</b>		<b>Premium suction hoses</b>		<b>Core premium ultra-abrasion hoses</b>	
<b>GH425</b> Core premium four wire spiral hose	42	<b>FC619</b> Core premium suction one wire braided hose	51 	<b>GH681B</b> Core premium ultra-abrasion one wire braided hose	58 
<b>GH493</b> Core premium four wire spiral hose	43 	<b>2661</b> Premium high-temp wire-inserted suction hose	52	<b>EC881B</b> Core premium Dynamax ultra-performance ultra-abrasion two wire braided hose	59 
<b>GH506</b> Core premium four wire spiral hose	44 			<b>GH425B</b> Premium ultra-abrasion four wire spiral hose	60 

## Premium hose



# GH681

Core premium  
one wire braided hose

Meets or exceeds: SAE 100R17 | EN 857 Type 1SC | ISO 1436 1SN | ISO 18752

	<b>GH681-4</b>	6.4 MM (0.25 IN) DN6	<b>Dura-Tuff</b>	Exceeds SAE 100R17 / EN 857 1SC Performance ISO 1436 1SN - MSHA IC-84/19 - ABS - DNV - USCG+	<b>255 BAR (3700 PSI)</b>	-46°C to +126°C -50°F to +260°F	1A 1R	
--	----------------	-------------------------	------------------	---	---------------------------	------------------------------------	----------	--

### Typical application:

Low and medium pressure hydraulic systems with petroleum and water-based fluids, construction equipment and agriculture equipment, industrial hydraulic systems. For applications where surpassing the 1SC standard is needed. Qualified to one million impulse cycles.

### Agency specifications:

MSHA | ABS | DNV | USCG

### Hose construction:

<b>Inner Tube:</b>	<b>Reinforcement:</b>	<b>Cover:</b>
Synthetic rubber	One wire braid	Dura-Tuff premium abrasion

### Operating temperature:

-46°C to +126°C (-50°F to +260°F)

### Qualified fittings:

1A (-4 to -32) | 1R (-4 -6 -8 -12 -16)

PART	SIZE DIMENSIONS					PRESSURE				BEND		WEIGHT	
	#	Hose I.D.			Hose O.D. (nominal)		Working Pressure		Min. Burst Pressure		Min. Bend Radius		Weight
	DN	mm	in	mm	in	bar	psi	bar	psi	mm	in	kg/m	lbs/ft
<b>GH681-3</b>	5	4.8	0.19	10.9	0.43	250	3,650	1,000	14,500	45	1.77	0.16	0.11
<b>GH681-4</b>	6	6.4	0.25	12.9	0.51	255	3,700	1,020	14,800	50	1.97	0.21	0.14
<b>GH681-5</b>	8	7.9	0.31	14.1	0.55	225	3,250	900	13,000	55	2.17	0.22	0.15
<b>GH681-6</b>	10	9.5	0.38	16.3	0.64	235	3,400	940	13,600	63	2.48	0.31	0.21
<b>GH681-8</b>	12	12.7	0.50	19.9	0.78	221	3,200	883	12,800	90	3.54	0.43	0.29
<b>GH681-10</b>	16	15.9	0.62	22.3	0.88	140	2,025	559	8,100	100	3.94	0.44	0.29
<b>GH681-12</b>	19	19.0	0.75	26.0	1.02	138	2,000	552	8,000	120	4.72	0.56	0.37
<b>GH681-16</b>	25	25.4	1.00	34.0	1.34	103	1,500	414	6,000	150	5.91	0.84	0.56
<b>GH681-20</b>	31	31.8	1.25	41.5	1.63	69	1,000	276	4,000	210	8.27	1.01	0.68
<b>GH681-24</b>	38	38.1	1.50	47.9	1.89	52	750	207	3,000	250	9.84	1.23	0.83
<b>GH681-32</b>	51	50.8	2.00	64.0	2.52	41	600	166	2,400	315	12.40	2.01	1.32

Also available with Bruiser ultra-abrasion resistant cover for the highest abrasion protection, see end of this chapter.



# FC510

Core premium AQP™ high-temp HI-PAC one wire braided hose

Exceeds: EN 857 1SC

**FC510-04**
 6.4 MM (0.25 IN) DN6
 AQP High-Temp Hi-Pac
 Exceeds EN 857 1SC MSHA IC-84/18 • DNV • USCG
 345 BAR (5000 PSI)
 -40°C to +149°C / -40°F to +300°F
 1A

### Typical application:

For applications operating in high temperature conditions, or applications with higher than average hydraulic fluid temperatures such as: mini excavators, skid steer loaders, mini hydraulic breakers, industrial high pressure compact power packs. Our Hi-Pac(kage) hoses have significantly higher volume of braiding compared with our general offering. This hose is specifically designed for to increase the pressure and impulse performance.

### Agency specifications:

MSHA | DNV | USCG

<b>Hose construction:</b>	<b>Inner Tube:</b>	<b>Reinforcement:</b>	<b>Cover:</b>
	AQP® Elastomer	Hi-Pac® one wire braid	Blue AQP Elastomer
<b>Operating temperature:</b>	-40°C to +149°C (-40°F to +300°F)		
<b>Qualified fittings:</b>	1A (-4 to -20)		

PART #	SIZE DIMENSIONS					PRESSURE				BEND		WEIGHT	
	Hose I.D.			Hose O.D. (nominal)		Working Pressure		Min. Burst Pressure		Min. Bend Radius		Weight	
	DN	mm	in	mm	in	bar	psi	bar	psi	mm	in	kg/m	lbs/ft
<b>FC510-04</b>	6	6.4	0.25	14.5	0.57	345	5,000	1,380	20,010	76	3.00	0.34	0.23
<b>FC510-06</b>	10	9.5	0.38	17.6	0.69	275	4,000	1,100	16,000	89	3.50	0.43	0.29
<b>FC510-08</b>	12	12.7	0.50	20.2	0.80	240	3,500	960	13,920	127	5.00	0.50	0.34
<b>FC510-10</b>	16	15.9	0.62	23.9	0.94	190	2,750	760	11,020	152	6.00	0.66	0.44
<b>FC510-12</b>	19	19.0	0.75	27.7	1.09	155	2,250	620	9,000	178	7.00	0.77	0.52
<b>FC510-16</b>	25	25.4	1.00	34.6	1.36	138	2,000	552	8,000	229	9.00	1.05	0.71
<b>FC510-20</b>	31	31.8	1.25	43.1	1.70	112	1,625	448	6,500	279	11.00	1.61	1.08



## Premium hose



Premium

# GH781

Core premium  
two wire braided hose

Meets or exceeds: SAE 100R16 | EN857 Type 2SC | ISO 18752

GH781-6
9.5 MM (0.38 IN) DN10
Dura-Tuff
Exceeds SAE 100R16 / EN857 2SC • ISO 18752  
MSHA IC-84/19 • ABS • DNV • USCG
 400 BAR (5800 PSI)
 -46°C to +126°C  
-50°F to +260°F
 Half Bend
 1A 2R

### Typical application:

For medium pressure diverse applications where all-round premium performance, and enhanced flexibility needed. Hydraulic systems service with petroleum and water-based fluids, for general use.

### Agency specifications:

MSHA | ABS | DNV | USCG

Hose construction:	Inner Tube:	Reinforcement:	Cover:
	Synthetic rubber	Two wire braid	Dura-Tuff premium abrasion

### Operating temperature:

-46°C to +126°C (-50°F to +260°F)

### Qualified fittings:

1A (-4 to 32) | 2R (-4 -6 -8 -12 -16)

PART #	SIZE DIMENSIONS					PRESSURE				BEND		WEIGHT	
	Hose I.D.			Hose O.D. (nominal)		Working Pressure		Min. Burst Pressure		Min. Bend Radius		Weight	
	DN	mm	in	mm	in	bar	psi	bar	psi	mm	in	kg/m	lbs/ft
<b>GH781-4</b>	6	6.4	0.25	13.9	0.55	448	6,500	1,792	26,000	50	1.96	0.33	0.22
<b>GH781-5</b>	8	7.9	0.31	14.5	0.59	350	5,100	1,400	20,400	55	2.16	0.36	0.24
<b>GH781-6</b>	10	9.5	0.38	17.5	0.69	400	5,800	1,600	23,200	65	2.55	0.43	0.29
<b>GH781-8</b>	12	12.7	0.50	20.9	0.82	350	5,100	1,400	20,400	90	3.54	0.58	0.39
<b>GH781-10</b>	16	15.9	0.62	24.0	0.94	280	4,050	1,120	16,200	100	3.94	0.65	0.44
<b>GH781-12</b>	19	19.0	0.75	27.9	1.10	240	3,500	960	14,000	120	4.72	0.79	0.53
<b>GH781-16</b>	25	25.4	1.00	35.9	1.41	210	3,050	840	12,200	150	5.90	1.07	0.72
<b>GH781-20</b>	31	31.8	1.25	43.4	1.71	172	2,500	688	10,000	210	8.26	1.62	1.09
<b>GH781-24</b>	38	38.1	1.50	51.5	2.03	140	2,050	560	8,200	250	9.84	2.08	1.40
<b>GH781-32</b>	51	50.8	2.00	63.9	2.52	110	1,600	440	6,400	315	12.40	2.82	1.90



# EC881

Core premium Dynamax ultra-performance two wire braided hose

**Exceeds:** SAE 100R16 Type S | EN 857 2SC | ISO 11237-1 Type 2SC

	<b>EC881-6</b>	9.5 MM (0.38 IN) DN10	Dura-Tuff Dynamax	Exceeds SAE 100R16 / 100R19 / EN857 2SC ISO 18752 • ABS • DNV • MSHA IC-84/56	<b>400 BAR (5800 PSI)</b>	-46°C to +126°C -50°F to +260°F	1/3 Bend	1A
--	----------------	-----------------------	-------------------	--	---------------------------	------------------------------------	----------	----

### Typical application:

Medium to high pressure hydraulic systems, petroleum & water-based fluids, construction equipment, agriculture equipment. This Dynamax ultra-performance hose with the Danfoss Dura-Pulse inner tube combines the lightweight flexibility of a two-wire braided hose with the pressure and performance of spiral 100R12 hoses (-16 and smaller). For high abrasion applications select Bruiser cover. Extra demanding applications requiring high performance- EC881 offers one million impulse cycle performance and 1/3 SAE bend radius.

### Agency specifications:

MSHA | ABS | DNV

<b>Hose construction:</b>	<b>Inner Tube:</b> Dura-Pulse™ patented tube	<b>Reinforcement:</b> Two wire braid	<b>Cover:</b> Dura-Tuff premium abrasion
<b>Operating temperature:</b>	-46°C to +126°C (-50°F to +260°F) -46° C to +70° C (-50°F to +158° F) for water-based hyd. fluids 0° C to +70° C (+32°F to 158° F) for water		
<b>Qualified fittings:</b>	1A (-4 to -32)		

PART #	SIZE DIMENSIONS					PRESSURE				BEND		WEIGHT	
	Hose I.D.			Hose O.D. (nominal)		Working Pressure		Min. Burst pressure		Min. Bend Radius		Weight	
	DN	mm	in	mm	in	bar	psi	bar	psi	mm	in	kg/m	lbs/ft
<b>EC881-4</b>	6	6.4	0.25	13.6	0.54	450	6,525	1,800	26,100	33	1.30	0.32	0.22
<b>EC881-5</b>	8	7.9	0.31	15.4	0.61	400	5,800	1,600	23,200	38	1.50	0.38	0.26
<b>EC881-6</b>	10	9.5	0.38	17.3	0.68	400	5,800	1,600	23,200	42	1.65	0.42	0.28
<b>EC881-8</b>	12	12.7	0.50	20.9	0.82	360	5,220	1,440	20,880	60	2.36	0.58	0.39
<b>EC881-10</b>	16	15.9	0.62	24.0	0.94	350	5,075	1,400	20,300	68	2.68	0.75	0.50
<b>EC881-12</b>	19	19.0	0.75	27.9	1.10	330	4,785	1,320	19,140	80	3.15	1.03	0.69
<b>EC881-16</b>	25	25.4	1.00	34.6	1.36	280	4,060	1,120	16,240	150	5.91	1.47	0.99
<b>EC881-20</b>	31	31.8	1.25	43.4	1.71	172	2,500	688	9,980	210	8.27	1.75	1.18
<b>EC881-24</b>	38	38.1	1.50	51.8	2.04	138	2,000	552	8,000	250	9.84	1.91	1.28
<b>EC881-32</b>	51	50.8	2.00	64.0	2.52	110	1,600	440	6,400	315	12.40	2.62	1.76

Also available with Bruiser ultra-abrasion resistant cover for the highest abrasion protection, see end of this chapter.

## Premium hose



# GH195

Core premium AQP high-temp  
two wire braided hose

Meets or exceeds: SAE 100R2 | EN 853 2SN | ISO 1436-1 2SN

<b>GH195-6</b>	9.5 MM (0.38 IN) DN10	AQP High-Temp	Exceeds SAE 100R2 / EN853 2SN - ISO 1436-1 2SN MSHA IC-84/18 - ABS - DNV - USCG	<b>345 BAR (5000 PSI)</b>	-40°C to +150°C -40°F to +302°F	1A
----------------	--------------------------	------------------	--	---------------------------	------------------------------------	----

### Typical application:

For applications operating in high temperature conditions, or applications with higher than average hydraulic fluid temperatures such as: mini excavators, skid steer loaders, mini hydraulic breakers, industrial high pressure compact power packs. With an AQP inner tube, it withstands temperatures up to 150°C.

### Agency specifications:

MSHA | ABS | DNV | USCG

<b>Hose construction:</b>	<b>Inner Tube:</b>	<b>Reinforcement:</b>	<b>Cover:</b>
	AQP elastomer	Two wire braid	Blue AQP elastomer
<b>Operating temperature:</b>	-40°C to +150°C (-40°F to +302°F)		
<b>Qualified fittings:</b>	1A (-4 to -32)		

PART #	SIZE DIMENSIONS					PRESSURE				BEND		WEIGHT	
	Hose I.D.			Hose O.D. (nominal)		Working Pressure		Min. Burst Pressure		Min. Bend Radius		Weight	
	DN	mm	in	mm	in	bar	psi	bar	psi	mm	in	kg/m	lbs/ft
<b>GH195-4</b>	6	6.4	0.25	15.1	0.59	400	5,800	1,600	23,200	102	4.02	0.40	0.27
<b>GH195-6</b>	10	9.5	0.38	19.2	0.75	345	5,000	1,380	20,000	127	5.00	0.58	0.39
<b>GH195-8</b>	12	12.7	0.50	22.1	0.87	293	4,250	1,172	17,000	178	7.01	0.68	0.46
<b>GH195-10</b>	16	15.9	0.62	25.5	1.00	250	3,650	1,000	14,600	203	7.99	0.80	0.54
<b>GH195-12</b>	19	19.0	0.75	29.5	1.16	215	3,125	860	12,500	241	9.49	1.00	0.67
<b>GH195-16</b>	25	25.4	1.00	37.8	1.49	175	2,550	700	10,200	305	12.01	1.44	0.97
<b>GH195-20</b>	31	31.8	1.25	48.5	1.91	155	2,250	620	9,000	419	16.50	2.38	1.60
<b>GH195-24</b>	38	38.1	1.50	55.1	2.17	125	1,800	500	7,250	508	20.00	2.59	1.74
<b>GH195-32</b>	51	50.8	2.00	67.8	2.67	105	1,525	420	6,100	635	25.00	3.38	2.27



Low-Temp



# GH120

 Core premium low-temp  
two wire braided hose

Exceeds: SAE 100R16 | EN 857 2SC | ISO 11237-1 2SC

	<b>GH120-6</b>	9.5 mm (0.38 in) DN10	Low-Temp	Exceeds SAE 100R16 / EN857 2SC ISO 11237-1	345 BAR (5000 PSI)	-57°C to +100°C -70°F to +212°F	1A
--	----------------	--------------------------	----------	---	--------------------	------------------------------------	----

### Typical application:

For applications operating in low temperature conditions, cold climate, extreme outdoor conditions such as snow snowploughs or material handling in freezer stores.

### Agency specifications:

MSHA

### Hose construction:

#### Inner Tube:

Special low temperature synthetic rubber

#### Reinforcement:

Two wire braid

#### Cover:

Dura-Tuff premium abrasion

### Operating temperature:

-57°C to +100°C (-70°F to +212°F)

### Qualified fittings:

1A (-4 to -32)

PART	SIZE DIMENSIONS					PRESSURE				BEND		WEIGHT	
	#	Hose I.D.			Hose O.D. (nominal)		Working Pressure		Min. Burst Pressure		Min. Bend Radius		Weight
	DN	mm	in	mm	in	bar	psi	bar	psi	mm	in	kg/m	lbs/ft
<b>GH120-4</b>	6	6.4	0.25	13.8	0.54	414	6,000	1,656	24,025	51	2.00	0.30	0.20
<b>GH120-6</b>	10	9.5	0.38	17.4	0.69	345	5,000	1,380	20,025	64	2.50	0.40	0.27
<b>GH120-8</b>	12	12.7	0.50	20.8	0.82	310	4,500	1,240	18,000	89	3.50	0.58	0.39
<b>GH120-10</b>	16	15.9	0.62	24.9	0.98	276	4,000	1,104	16,000	102	4.00	0.74	0.50
<b>GH120-12</b>	19	19.0	0.75	28.5	1.12	241	3,500	964	14,000	121	4.75	0.92	0.62
<b>GH120-16</b>	25	25.4	1.00	35.7	1.41	193	2,800	772	11,200	152	6.00	1.22	0.82
<b>GH120-20</b>	31	31.8	1.25	43.3	1.71	159	2,300	636	9,225	210	8.25	1.59	1.07
<b>GH120-24</b>	38	38.1	1.50	51.5	2.03	138	2,000	552	8,000	254	10.00	2.11	1.42
<b>GH120-32</b>	51	50.8	2.00	63.9	2.51	103	1,500	412	6,000	318	12.50	2.80	1.88

## Premium hose



# GH425

Core premium  
four wire spiral hose

Exceeds: EN 856 4SP

**GH425-8** 12.7 MM (0.50 IN) DN12 **Dura-Tuff**
Exceeds EN 856 4SP  
MSHA IC-84/56 · ABS · DNV
**420 BAR (6100 PSI)**

 -40°C to +100°C  
 -40°F to +212°F
 1T

### Typical application:

High pressure hydraulic system service with petroleum and water-base fluids applications. Enhanced compatibility for water-based fluids makes this hose suitable for underground mining applications.

**Agency specifications:** MSHA | DNV | ABS

<b>Hose construction:</b>	<b>Inner tube:</b>	<b>Reinforcement:</b>	<b>Cover:</b>
	Synthetic rubber	Four wire spiral	Dura-Tuff premium abrasion

**Operating temperature:** -40°C to +100°C (-40°F to +212°F)

**Qualified fittings:** 1T (-6 to -10) | 4S (-12 to -16)

PART #	SIZE DIMENSIONS					PRESSURE				BEND		WEIGHT	
	Hose I.D.			Hose O.D. (nominal)		Working Pressure		Min. Burst Pressure		Min. Bend Radius		Weight	
	DN	mm	in	mm	in	bar	psi	bar	psi	mm	in	kg/m	lbsft
<b>GH425-6</b>	10	9.5	0.38	20.5	0.81	490	7,100	1,960	28,400	180	7.09	0.70	0.47
<b>GH425-8</b>	12	12.7	0.50	24.0	0.94	420	6,100	1,680	24,400	230	9.06	0.92	0.62
<b>GH425-10</b>	16	15.9	0.62	27.9	1.10	420	6,100	1,680	24,400	250	9.84	1.13	0.76
<b>GH425-12</b>	19	19.0	0.75	32.0	1.26	380	5,500	1,520	22,000	300	11.81	1.50	1.01
<b>GH425-16</b>	25	25.4	1.00	39.0	1.54	320	4,650	1,280	18,600	340	13.39	2.15	1.44

Also available with Bruiser cover for higher abrasion resistance, see end of this chapter.



# GH493

Core premium  
four wire spiral hose

Meets or exceeds: SAE 100R12 | EN856 Type 4SP (-10 to -32) |  
EN856 Type R12 | ISO 18752

	<b>GH493-12</b>	19.0 mm (0.75 in) DN19	Dura-Tuff	Exceeds SAE 100R12 / EN 856 R12 • ISO 18752 MSHA IC-84/19 • ABS • DNV • USCG +	380 BAR (5500 PSI)	-40°C to +126°C -40°F to +260°F	Half Bend	4S
--	-----------------	---------------------------	-----------	---	--------------------	------------------------------------	-----------	----

### Typical application:

A versatile hose compliant with 4 main industry standards, for very high pressure hydraulic lines subjected to pressure surges and flexing. Typical applications include construction, mining, farming and high performance industrial equipment. Sizes -6 and -8 meet the working and the burst pressure but not the impulse pressure performance of EN 856 4SP.

Agency specifications: MSH | ABS | DNV | USCG

<b>Hose construction:</b>	<b>Inner Tube:</b>	<b>Reinforcement:</b>	<b>Cover:</b>
	Synthetic rubber	Four wire spiral	Dura-Tuff® Premium Abrasion
<b>Operating temperature:</b>	-40°C to +126°C (-40°F to +260°F)		
<b>Qualified fittings:</b>	1T (-6 -8 -10)   4S (-6 to -32)		

PART #	SIZE DIMENSIONS					PRESSURE				BEND		WEIGHT	
	Hose I.D.			Hose O.D. (nominal)		Working Pressure		Min. Burst Pressure		Min. Bend Radius		Weight	
	DN	mm	in	mm	in	bar	psi	bar	psi	mm	in	kg/m	lbs/ft
<b>GH493-6*</b>	10	9.5	0.38	20.2	0.80	448	6,500	1,792	26,000	63	2.46	0.71	0.47
<b>GH493-8*</b>	12	12.7	0.50	23.6	0.93	415	6,000	1,660	24,000	90	3.54	0.88	0.59
<b>GH493-10</b>	16	15.9	0.62	27.4	1.08	415	6,000	1,660	24,000	100	3.94	1.04	0.70
<b>GH493-12</b>	19	19.0	0.75	30.7	1.21	380	5,500	1,520	22,000	120	4.72	1.34	0.90
<b>GH493-16</b>	25	25.4	1.00	37.9	1.49	350	5,100	1,400	20,400	150	5.91	1.79	1.20
<b>GH493-20</b>	31	31.8	1.25	46.6	1.83	310	4,500	1,240	18,000	210	8.27	2.23	1.50
<b>GH493-24</b>	38	38.1	1.50	53.9	2.12	275	4,000	1,100	16,000	250	9.84	3.03	2.03
<b>GH493-32</b>	51	50.8	2.00	66.8	2.63	275	4,000	1,100	16,000	320	12.60	4.38	2.94

\* Sizes -6 and -8 meet the working and burst pressure but not the impulse pressure performance of EN 856 4SP.



## Premium hose



# GH506

Core premium  
four wire spiral hose

Meets or exceeds: EN 856 Type 4SH | ISO 18752 | ISO 3862 Type 4SH

	<b>GH506-12</b>	<small>19.0 mm (0.75 in) DN19</small>	<b>Dura-Tuff</b>	<small>EN 856 4SH - ISO 3862 4SH - ISO 18752 MSHA IC-84/19 - ABS - DNV</small>	<b>420 BAR (6100 PSI)</b>	<small>-40°C to +100°C -40°F to +212°F</small>	<b>1W</b>
--	-----------------	---	------------------	--	---------------------------	--	-----------

### Typical application:

High pressure hydraulic systems with petroleum and water-glycol based fluids. Challenging applications like construction equipment, agriculture machines, stationary applications. 2 Million flex impulse cycle performance according ISO6802 for size 12' and 16'.

### Agency specifications:

MSHA | DNV | ABS

### Hose construction:

<b>Inner Tube:</b> Synthetic rubber	<b>Reinforcement:</b> Four wire spiral	<b>Cover:</b> Dura-Tuff premium abrasion
--	---	---

### Operating temperature:

-40°C to +100°C (-40°F to +212°F), short term to +120°C (+248°F)

### Qualified fittings:

1W (-12 to -32)

PART	SIZE DIMENSIONS					PRESSURE				BEND		WEIGHT	
	#	Hose I.D.			Hose O.D. (nominal)		Working Pressure		Min. Burst Pressure		Min. Bend Radius		Weight
	DN	mm	in	mm	in	bar	psi	bar	psi	mm	in	kg/m	lbs/ft
<b>GH506-12*</b>	19	19.0	0.75	32.2	1.27	420	6,100	1,680	24,400	280	11.02	1.49	1.00
<b>GH506-16*</b>	25	25.4	1.00	38.3	1.51	420	6,100	1,680	24,400	340	13.39	2.05	1.38
<b>GH506-20</b>	31	31.8	1.25	45.5	1.79	350	5,100	1,400	20,300	460	18.11	2.54	1.71
<b>GH506-24</b>	38	38.1	1.50	53.5	2.11	300	4,350	1,200	17,400	560	22.05	3.27	2.20
<b>GH506-32</b>	51	50.8	2.00	68.1	2.68	250	3,650	1,000	14,500	700	27.56	4.58	3.08

\* 2 Million flex impulse cycle performance according ISO6802



# FC500

Core premium X-Flex®  
four and six wire spiral hose

Meets or exceeds: SAE 100R13 | EN 856 R13 | ISO 3862 R13

by Danfoss	<b>FC500-16</b>	25.4 mm (1.00 in) DN25	Dura-Tuff X-Flex	Exceeds SAE 100R13 / EN 856 R13 / ISO 3862 R13 MSHA IC-84/19 - DNV - USCG	350 BAR (5100 PSI)	-40°C to +127°C -40°F to +260°F	Half Bend	4S
------------	-----------------	---------------------------	---------------------	--	--------------------	------------------------------------	-----------	----

**Typical application:**

High pressure hydraulic system service with petroleum and water-base fluids for applications where extra flexibility needed.

**Agency specifications:** MSHA | USCG

<b>Hose construction:</b>	<b>Inner Tube:</b> Synthetic rubber	<b>Reinforcement:</b> Four wire spiral (-12 to -24) Six wire spiral (-32)	<b>Cover:</b> Dura-Tuff premium abrasion
---------------------------	--	---	---

**Operating temperature:** -40°C to +127°C (-40°F to +260°F)

**Qualified fittings:** 4S (-12 to -24) | 6S (-32)

PART #	SIZE DIMENSIONS					PRESSURE				BEND		WEIGHT	
	Hose I.D.			Hose O.D. (nominal)		Working Pressure		Min. Burst Pressure		Min. Bend Radius		Weight	
	DN	mm	in	mm	in	bar	psi	bar	psi	mm	in	kg/m	lbs/ft
<b>FC500-12</b>	19	19.0	0.75	31.0	1.22	350	5,100	1,400	20,400	121	4.75	1.28	0.86
<b>FC500-16</b>	25	25.4	1.00	38.4	1.51	350	5,100	1,400	20,400	152	6.00	1.85	1.24
<b>FC500-20</b>	31	31.8	1.25	45.5	1.79	350	5,100	1,400	20,400	210	8.25	2.50	1.68
<b>FC500-24</b>	38	38.1	1.50	53.5	2.11	350	5,100	1,400	20,400	254	10.00	3.38	2.27
<b>FC500-32</b>	51	50.8	2.00	71.8	2.83	350	5,100	1,400	20,400	476	18.75	6.07	4.08

## Premium hose

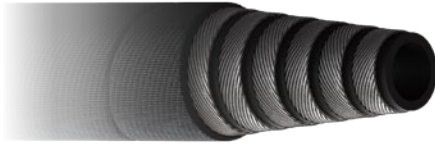

# GH466

Core premium  
six wire spiral hose

Meets or exceeds: SAE 100R15 | ISO 3862 Type R15 | EN856 R13

**GH466-24**  
31.8 mm (1.25 in) DN20

**Dura-Tuff**  
2M Cycles

Exceeds SAE 100R15 / EN856 R13  
MSHA IC-84/19 • ABS • DNV

**420 BAR (6100 PSI)**

-40°C to +121°C  
-40°F to +250°F

**1W 6S**

### Typical application:

High pressure hydraulic systems with constant high working pressure for use with petroleum and water-glycol based fluids. 2 Million flex impulse cycle performance according ISO6802.

### Agency specifications:

MSHA | DNV | ABS

### Hose construction:

Inner Tube:	Reinforcement:	Cover:
Synthetic rubber	Six wire spiral	Dura-Tuff premium abrasion

### Operating temperature:

-40°C to +121°C (-40°F to +250°F)

### Qualified fittings:

6S (-20 to -24) | 1W (-20 to -32)

PART #	SIZE DIMENSIONS					PRESSURE				BEND		WEIGHT	
	Hose I.D.			Hose O.D. (nominal)		Working Pressure		Min. Burst Pressure		Min. Bend Radius		Weight	
	DN	mm	in	mm	in	bar	psi	bar	psi	mm	in	kg/m	lbs/ft
<b>GH466-20</b>	31	31.8	1.25	49.4	1.94	420	6,100	1,680	24,400	420	16.53	3.48	2.34
<b>GH466-24</b>	38	38.1	1.50	57.3	2.26	420	6,100	1,680	24,400	500	19.69	4.63	3.11
<b>GH466-32</b>	51	50.8	2.00	71.7	2.82	420	6,100	1,490	21,600	630	24.80	6.70	4.50

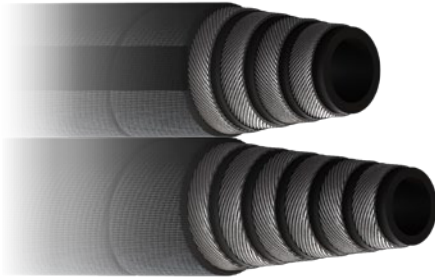

# EC600

Core premium X-Flex®  
four and six wire spiral hose

Meets or exceeds: SAE 100R15 | ISO 18752-DC

<b>EC600-12</b>	19.0 MM (0.75 IN) DN19	Dura-Tuff X-Flex	Exceeds SAE 100R15 • ISO 18752 MSHA IC-84/19 • ABS • DNV • USCG+	420 BAR (6100 PSI)	-40°C to +127°C -40°F to +260°F	Half Bend	1W <b>4S</b>
-----------------	---------------------------	---------------------	---	--------------------	------------------------------------	-----------	--------------

### Typical application:

For applications where extra flexibility and high pressure is needed, like hydrostatic drives and large excavator work cycles. High pressure hydraulic system service with petroleum and waterglycol based fluids, for general industrial service where extra flexibility needed.

**Agency specifications:** MSHA | ABS | USCG | DNV

<b>Hose construction:</b>	<b>Inner Tube:</b> Dura-Pulse patented tube	<b>Reinforcement:</b> Four wire spiral (-12 to -16) Six wire spiral (-20 to -32)	<b>Cover:</b> Dura-Tuff premium abrasion
<b>Operating Temperature:</b>	-40°C to +127°C (-40°F to +260°F)		
<b>Qualified fittings:</b>	4S (-12 to -16)   6S (-20 to 32)   1W (-12 to -32)		

PART #	SIZE DIMENSIONS					PRESSURE				BEND		WEIGHT	
	Hose I.D.			Hose O.D. (nominal)		Working Pressure		Min. Burst Pressure		Min. Bend Radius		Weight	
	DN	mm	in	mm	in	bar	psi	bar	psi	mm	in	kg/m	lbs/ft
<b>EC600-12</b>	19	19.0	0.75	32.2	1.27	420	6,100	1,680	24,400	135	5.31	1.52	1.01
<b>EC600-16</b>	25	25.4	1.00	38.6	1.52	420	6,100	1,680	24,400	165	6.50	2.04	1.36
<b>EC600-20</b>	31	31.8	1.25	49.7	1.96	420	6,100	1,680	24,400	225	8.86	3.89	2.61
<b>EC600-24</b>	38	38.1	1.50	57.5	2.26	420	6,100	1,680	24,400	265	10.43	4.83	3.24
<b>EC600-32*</b>	51	50.8	2.00	71.0	2.79	420	6,100	1,680	24,400	375	14.76	7.10	4.77

\* EC600-32 meets ISO 18752-DC performance to 400,000 cycles.

## Premium hose

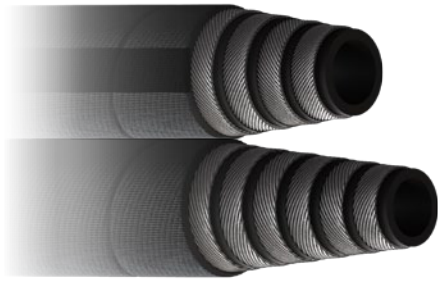

# EC850

Core Dynamax ultra-performance  
four and six wire spiral hose

Meets or exceeds: SAE 100R15 | ISO 18752 | EN 856 R13

	<b>EC850-12</b>	19.0 mm (0.75 in) DN19	<b>Dura-Tuff Dynamax</b>	SAE 100R15 / EN 856R13 Type ISO 18752 • MSHA IC-84/56	<b>500 BAR (7250 PSI)</b>	-40°C to +100°C -40°F to +212°F	<b>1W</b>
--	-----------------	---------------------------	------------------------------	--	---------------------------	------------------------------------	-----------

### Typical application:

Demanding ultra-high pressure applications requiring EN856 R13 and SAE J517 100R15 compliant solutions at pressures up to 500 bar—including hydrostatic drives, direct drive steering systems and critical subsystems in off-highway equipment delivering up to 3 million impulse cycles in sizes -10 and -12.

**Agency specifications:** MSHA

<b>Hose construction:</b>	<b>Inner Tube:</b> Synthetic rubber	<b>Reinforcement:</b> Four wire spiral (-10, -12, -16) Six wire spiral (-20)	<b>Cover:</b> Dura-Tuff premium abrasion
---------------------------	--	--	---

**Operating temperature:** -40°C to +100°C (-40°F to +212°F)

**Qualified fittings:** 1W (-10 to -20)

PART #	SIZE DIMENSIONS					PRESSURE				BEND		WEIGHT	
	Hose I.D.			Hose O.D. (nominal)		Working Pressure		Min. Burst Pressure		Min. Bend Radius		Weight	
	DN	mm	in	mm	in	bar	psi	bar	psi	mm	in	kg/m	lbs/ft
<b>EC850-10</b>	16	15.9	0.62	27.9	1.10	500	7,250	2,000	29,000	200	7.87	1.23	0.82
<b>EC850-12</b>	19	19.0	0.75	32.2	1.27	500	7,250	2,000	29,000	215	8.46	1.52	1.01
<b>EC850-16</b>	25	25.4	1.00	39.2	1.54	500	7,250	2,000	29,000	270	10.63	2.31	1.54
<b>EC850-20</b>	31	31.8	1.25	49.4	1.94	500	7,250	2,000	29,000	380	14.96	4.01	2.69



# EC525

Core premium AQP high-temp  
four wire spiral hose

Exceeds: SAE 100R12 | EN 856 R12

**EC525-12** 19.0 MM (0.75 IN) DN19 **AQP High-Temp** MSHA IC-84/18 **345 BAR (5000 PSI)** -40°C to +149°C / -40°F to +300°F **4S**

### Typical application:

For applications operating in high temperature conditions, or applications with higher than average hydraulic fluid temperatures such as: mini excavators, skid steer loaders, mini hydraulic breakers, industrial high pressure compact power packs. With an AQP inner tube, it withstands temperatures up to 150°C.

### Agency specifications:

MSHA

Hose construction:	Inner Tube:	Reinforcement:	Cover:
	AQP Elastomer	Four wire spiral	Blue AQP elastomer

### Operating Temperature:

Typical fluids: -40°C To +149°C (-40°F To +300°F)  
Phosphate-ester base fluids: -40°C To +82°C (-40°F To +180°F)

### Qualified fittings:

4S (-12 to -32)

PART #	SIZE DIMENSIONS					PRESSURE				BEND		WEIGHT	
	Hose I.D.			Hose O.D. (nominal)		Working Pressure		Min. Burst Pressure		Min. Bend Radius		Weight	
	DN	mm	in	mm	in	bar	psi	bar	psi	mm	in	kg/m	lbs/ft
<b>EC525-12</b>	19	19.0	0.75	30.7	1.21	345.0	5,000	1,380	20,000	241	9.50	1.28	0.86
<b>EC525-16</b>	25	25.4	1.00	37.9	1.49	345.0	5,000	1,380	20,000	305	12.00	1.73	1.16
<b>EC525-20</b>	31	31.8	1.25	46.6	1.83	240.0	3,500	960	14,000	419	16.50	2.31	1.55
<b>EC525-24</b>	38	38.1	1.50	53.9	2.12	240.0	3,500	960	14,000	508	20.00	2.96	1.99
<b>EC525-32</b>	51	50.8	2.00	67.3	2.65	225.0	3,250	900	13,000	635	25.00	4.42	2.97



## Premium hose



# EC810

Core premium low-temp  
four and six wire spiral hose

**EC810-12** 19.0 MM (0.75 IN) DN19 **Low-Temp**
MSHA IC-84/68
 **420 BAR (6100 PSI)**
 -57°C to +100°C  
-70°F to +212°F
 **4S**

### Typical application:

For applications operating in low temperature conditions, cold climate, extreme outdoor conditions such as snow snowploughs or material handling in freezer stores.

**Agency specifications:** MSHA

Hose construction:	Inner tube:	Reinforcement:	Cover:
Special low temperature synthetic rubber	Special low temperature synthetic rubber	Four wire spiral (-12 to -16) Six wire spiral (-20 to -32)	Synthetic rubber

**Operating temperature:** -57°C to +100°C (-70°F to +212°F)

**Qualified fittings:** 4S (-12 to -16) | 6S (-20 to -32) | 1W (-12 to -32)

PART #	SIZE DIMENSIONS					PRESSURE				BEND		WEIGHT	
	Hose I.D.			Hose O.D. (nominal)		Working Pressure		Min. Burst Pressure		Min. Bend Radius		Weight	
	DN	mm	in	mm	in	bar	psi	bar	psi	mm	in	kg/m	lbs/ft
<b>EC810-06</b>	10	9.5	0.38	21.4	0.84	420	6,100	1,680	24,360	180	7.09	0.74	0.50
<b>EC810-08</b>	12	12.7	0.50	24.6	0.97	420	6,100	1,680	24,360	230	9.06	0.95	0.64
<b>EC810-10</b>	16	15.9	0.62	28.2	1.11	420	6,100	1,680	24,360	250	9.84	1.11	0.75
<b>EC810-12</b>	19	19.0	0.75	32.2	1.27	420	6,100	1,680	24,360	280	11.02	1.61	1.08
<b>EC810-16</b>	25	25.4	1.00	39.0	1.54	420	6,100	1,680	24,360	340	13.39	2.02	1.36
<b>EC810-20</b>	31	31.8	1.25	49.4	1.94	420	6,100	1,680	24,360	420	16.54	3.55	2.39
<b>EC810-24</b>	38	38.1	1.50	57.3	2.26	420	6,100	1,680	24,360	510	20.08	4.74	3.19
<b>EC810-32*</b>	51	50.8	2.00	71.7	2.82	420	6,100	1,490	21,610	630	24.80	6.70	4.50

\*With the 6S fitting the -32 size working pressure is 350 bar (5100 psi) with a 4:1 safety factor.



Suction

# FC619

 Core premium suction  
one wire braided hose

Exceeds: SAE 100R4 | EN 45545

	<b>FC619-12</b>	19.0 MM (0.75 IN) DN19	<b>Dura-Tuff</b>	Exceeds SAE 100R4 • ABS MSHA IC-84/19 • EN45545	<b>21 BAR (305 PSI)</b>	-40°C to +135°C -40°F to +275°F	1/3 Bend	4S • 1A 1G
--	-----------------	---------------------------	------------------	--	-------------------------	------------------------------------	----------	---------------

### Typical application:

Suction and transfer applications for petroleum hydraulic fluids, fuel, lubricating oils, gasoline, water and many other industrial fluids. Applicable also for high temperature liquids, up to 135°C.

**Agency specifications:** MSHA | EN45545 | ABS

Hose construction:	Inner Tube:	Reinforcement:	Cover:
AQP elastomer		Helical wire between two textile reinforcement layers	Synthetic rubber

**Operating temperature:** -40°C to +135°C (-40°F to +275°F)

**Qualified fittings:** 1A (-12 -16 -20 -24 -32) | 1G (-12 -16 -20 -24 -32) | 4S (-12)

PART #	SIZE DIMENSIONS					PRESSURE				BEND		VACUUM		WEIGHT	
	Hose I.D.		Hose O.D. (nominal)		Working Pressure		Min. Burst Pressure		Min. Bend Radius		Vacuum		Weight		
	DN	mm	in	mm	in	bar	psi	bar	psi	mm	in	kPa	in/Hg	kg/m	lbs/ft
<b>FC619-12</b>	19	19.0	0.75	30.0	1.18	21.0	305 †	84	1,220	40	1.57	94.8	28	0.65	0.44
<b>FC619-16</b>	25	25.4	1.00	37.1	1.46	17.0	245 †	68	980	45	1.77	94.8	28	0.77	0.52
<b>FC619-20</b>	31	31.8	1.25	44.8	1.76	14.0	205 †	56	820	60	2.36	94.8	28	1.12	0.75
<b>FC619-24</b>	38	38.1	1.50	51.2	2.01	10.5	150 †	42	600	65	2.56	94.8	28	1.26	0.85
<b>FC619-32</b>	51	50.8	2.00	64.8	2.55	7.0	100 †	28	400	100	3.94	94.8	28	1.73	1.16
<b>FC619-40*</b>	63	63.5	2.50	77.7	3.06	4.0	60	16	240	140	5.51	94.8	28	2.35	1.58
<b>FC619-48*</b>	76	76.2	3.00	92.5	3.64	4.0	60	16	240	279.4	11.00	94.8	28	3.36	2.26

\*Only bulk hose

† Maximum working pressure for band clamp type fittings is 3.4 bar [50 psi]

## Premium hose

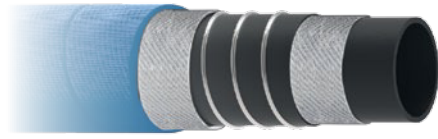

Suction



High-Temp

# 2661

Premium high-temp wire-inserted suction hose

Exceeds: SAE 100R4

**2661-12** 19.0 MM (0.75 IN) DN19 **AQP High-Temp** Exceeds SAE 100R4 MSHA IC-84/18 • USCG **21 BAR (305 PSI)** -40°C to +149°C -40°F to +300°F **1A** **1G**

### Typical application:

Suction and transfer applications for petroleum hydraulic fluids, fuel, lubricating oils, gasoline, water and many other industrial fluids. Applicable also for high temperature liquids, up to 149°C and in hot environments, such as motor compartments.

### Agency specifications:

MSHA | USCG

<b>Hose construction:</b>	<b>Inner Tube:</b> AQP elastomer	<b>Reinforcement:</b> Helical wire between two textile reinforcement layers	<b>Cover:</b> Blue AQP elastomer
---------------------------	-------------------------------------	--	-------------------------------------

### Operating temperature:

-40°C to +149°C (-40°F to +300°F)

### Qualified fittings:

1A (-12 -16 -20 -24 -32) | 1G (-12 -16 -20 -24 -32)

PART #	SIZE DIMENSIONS					PRESSURE				BEND		VACUUM		WEIGHT	
	Hose I.D.		Hose O.D. (nominal)			Working Pressure		Min. Burst Pressure		Min. Bend Radius		Vacuum		Weight	
	DN	mm	in	mm	in	bar	psi	bar	psi	mm	in	kPa	in/Hg	kg/m	lbs/ft
<b>2661-12</b>	19	19.0	0.75	31.8	1.25	21	305 †	84	1,220	125	4.92	94.8	28	0.62	0.42
<b>2661-16</b>	25	25.4	1.00	38.0	1.50	17.5	255 †	70	1,020	150	5.91	94.8	28	0.74	0.50
<b>2661-20</b>	31	31.8	1.25	45.8	1.80	14	205 †	56	820	200	7.87	94.8	28	1.34	0.90
<b>2661-24</b>	38	38.1	1.50	53.1	2.09	11	160 †	44	640	255	10.04	94.8	28	1.68	1.13
<b>2661-32</b>	51	50.8	2.00	64.8	2.55	7	100 †	28	400	300	11.81	94.8	28	1.93	1.30
<b>2661-40*</b>	63	63.5	2.50	78.0	3.07	4.5	65	18	260	355	13.98	94.8	28	2.56	1.72
<b>2661-48*</b>	76	76.2	3.00	92.5	3.64	4	60	16	240	457	17.99	94.8	28	2.92	1.96
<b>2661-64*</b>	102	101.6	4.00	119.1	4.69	3.5	50	14	200	610	24.02	94.8	28	4.58	3.08

\*Only bulk hose

† Maximum working pressure for band clamp type fittings is 3.4 bar [50 psi]

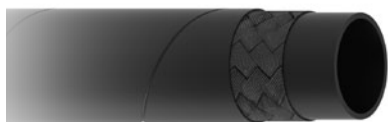

# GH585

Premium one textile braided hose

Exceeds: EN 854 2TE



### Typical application:

Hydraulic systems with petroleum base fluids for fuel and lubricating oils, air\* and water.

\* Rubber covered hose styles for use with gases above 17,5 bar (250 psi) must be perforated.

### Agency specifications:

MSHA

### Hose construction:

#### Inner tube:

Synthetic rubber

#### Reinforcement:

One synthetic textile braid

#### Cover:

Synthetic rubber

### Operating temperature:

-40°C to +100°C ( up to +125°C ) (-40°F to +212°F)

### Qualified fittings:

1G (-3 to -16)

PART	SIZE DIMENSIONS					PRESSURE				BEND		WEIGHT	
	#	Hose I.D.			Hose O.D. (nominal)		Working Pressure		Min. Burst Pressure		Min. Bend Radius		Weight
	DN	mm	in	mm	in	bar	psi	bar	psi	mm	in	kg/m	lbsft
<b>GH585-3</b>	5	4.8	0.19	11.8	0.46	80	1,160	320	4,600	35	1.38	0.12	0.08
<b>GH585-4</b>	6	6.4	0.25	13.4	0.53	75	1,100	300	4,400	40	1.57	0.14	0.09
<b>GH585-5</b>	8	7.9	0.31	14.9	0.59	68	985	272	3,940	50	1.97	0.17	0.11
<b>GH585-6</b>	10	9.5	0.38	16.5	0.65	63	915	252	3,660	60	2.36	0.18	0.12
<b>GH585-8</b>	12	12.7	0.50	19.7	0.78	58	840	232	3,360	70	2.76	0.22	0.15
<b>GH585-10</b>	16	15.9	0.62	23.9	0.94	50	725	200	2,900	90	3.54	0.30	0.20
<b>GH585-12</b>	19	19.0	0.75	27.0	1.06	45	655	180	2,620	110	4.33	0.35	0.24
<b>GH585-16</b>	25	25.4	1.00	34.4	1.35	40	580	160	2,320	150	5.91	0.49	0.33

## Premium hose



Premium

# FC310

Premium Hi-Pac mining  
one wire braided hose

Meets: SAE 100R2 performance

Aeroquip by Danfoss FC310-08 12.7 MM (0.50 IN) DN 12 240 BAR (3500 PSI) MSHA IC-84/19

### Typical application:

Our Hi-Pac(kage) hoses have significantly higher volume of braiding compared with our general offering. This hose is specifically designed for mining applications to increase the pressure and impulse performance.

### Agency specifications:

MSHA | DNV

### Hose construction:

#### Inner tube:

Synthetic rubber

#### Reinforcement:

One wire braid Hi-Pac

#### Cover:

Synthetic rubber

### Operating temperature:

-40°C to +100°C (-40°F to +212°F)

### Qualified fittings:

1A (-3 to -20)

PART	SIZE DIMENSIONS					PRESSURE				BEND		WEIGHT	
	#	Hose I.D.			Hose O.D. (nominal)		Working Pressure		Min. Burst Pressure		Min. Bend Radius		Weight
	DN	mm	in	mm	in	bar	psi	bar	psi	mm	in	kg/m	lbsft
<b>FC310-03</b>	5	4.8	0.19	11.8	0.46	350	5,100	1,400	20,300	45	1.77	0.23	0.15
<b>FC310-04</b>	6	6.4	0.25	14.1	0.56	345	5,000	1,380	20,000	50	1.97	0.28	0.19
<b>FC310-05</b>	8	7.9	0.31	15.4	0.61	300	4,350	1,200	17,400	60	2.36	0.32	0.22
<b>FC310-06</b>	10	9.5	0.38	17.1	0.67	275	4,000	1,100	16,000	65	2.56	0.36	0.24
<b>FC310-08</b>	12	12.7	0.50	20.2	0.80	240	3,500	960	13,930	90	3.54	0.45	0.30
<b>FC310-10</b>	16	15.9	0.62	23.8	0.94	190	2,750	760	11,020	100	3.94	0.54	0.36
<b>FC310-12</b>	19	19.0	0.75	27.4	1.08	155	2,250	620	8,990	120	4.72	0.70	0.47
<b>FC310-16</b>	25	25.4	1.00	34.6	1.36	138	2,000	552	8,000	150	5.90	0.98	0.66
<b>FC310-20</b>	31	31.8	1.25	43.3	1.70	112	1,625	448	6,500	210	8.27	1.46	0.98



# SH222

Premium Hi-Pac mining  
two wire braided hose

Exceeds: EN 853 2SN



<b>SH222-6</b>	9.5 MM (0.37 IN) DN10	Hi-Pac Dura-Tuff	Exceeds EN 853 2SN Performance MSHA I C-84/56	<b>350 BAR (5100 PSI)</b>	-40°C to +100°C -40°F to +212°F	1A
----------------	--------------------------	---------------------	--	---------------------------	------------------------------------	----

### Typical application:

Our Hi-Pac(kage) hoses have significantly higher volume of braiding compared with our general offering. This hose is specifically designed for mining applications to increase the pressure and impulse performance.

**Agency specifications:** MSHA

<b>Hose construction:</b>	<b>Inner tube:</b> Synthetic rubber	<b>Reinforcement:</b> Two wire braid Hi-Pac	<b>Cover:</b> Dura-Tuff premium abrasion
---------------------------	--	--	---

**Operating temperature:** -40°C to +100°C (-40°F to +212°F)

**Qualified fittings:** 1A (-4 to -16)

PART #	SIZE DIMENSIONS					PRESSURE				BEND		WEIGHT	
	Hose I.D.			Hose O.D. (nominal)		Working Pressure		Min. Burst Pressure		Min. Bend Radius		Weight	
	DN	mm	in	mm	in	bar	psi	bar	psi	mm	in	lbsft	kg/m
<b>SH222-4</b>	6	6.4	0.25	15.0	0.59	400	5,800	1,600	23,200	70	2.76	0.39	0.58
<b>SH222-6</b>	10	9.5	0.38	19.0	0.75	350	5,100	1,400	20,300	90	3.54	0.56	0.83
<b>SH222-8</b>	12	12.7	0.50	22.2	0.87	300	4,350	1,200	17,445	120	4.72	0.68	1.01
<b>SH222-12</b>	19	19.0	0.75	29.9	1.18	300	4,350	1,200	17,445	170	6.69	1.07	1.59
<b>SH222-16</b>	25	25.4	1.00	36.8	1.45	240	3,500	960	13,910	210	8.27	1.38	2.05



## Premium hose



Premium



# GH507

Premium heavy wire  
four spiral hose

Exceeds: EN 856 4SH | SAE 100R15



## GH507-20

31.8 MM (1.25 IN)  
DN31

Exceeds SAE 100R15 • MSHA IC-84/55  
Exceeds EN 856 4SH Performance

**420 BAR (6100 PSI)**

-40°C to +120°C  
 -40°F to +248°F

### Typical application:

High pressure hydraulic systems with petroleum and water-glycol based fluids. Challenging applications like construction equipment, agriculture machines, stationary applications .

### Agency specifications:

MSHA

### Hose construction:

#### Inner Tube:

Synthetic rubber

#### Reinforcement:

Four heavy wire spiral

#### Cover:

Synthetic rubber

### Operating temperature:

-40°C to +120°C (-40°F to +248°F)

### Qualified fittings:

1W

PART #	SIZE DIMENSIONS					PRESSURE				BEND		WEIGHT	
	Hose I.D.			Hose O.D. (nominal)		Working Pressure		Min. Burst Pressure		Min. Bend Radius		Weight	
	DN	mm	in	mm	in	bar	psi	bar	psi	mm	in	kg/m	lbsft
<b>GH507-20</b>	31	31.8	1.25	46.8	1.84	420	6,100	1,560	22,625	420	16.54	2.74	1.84



# GH435

Premium phosphate-ester  
four wire spiral hose



### Typical application:

For hydraulic systems with phosphate ester fluids (HFD fluids). Great compatibility against aggressive fluids such as phosphate ester due to the special inner tube.

### Agency specifications:

<b>Hose construction:</b>	<b>Inner tube:</b> Polyamide	<b>Reinforcement:</b> Four spiral wire	<b>Cover:</b> Synthetic EPDM rubber
<b>Operating temperature:</b>	-40°C to +70°C (-40°F to +158°F)		
<b>Qualified fittings:</b>	1T (-6 to -10)   4S (-12 to -16)		

PART #	SIZE DIMENSIONS					PRESSURE				BEND		WEIGHT	
	Hose I.D.			Hose O.D. (nominal)		Working Pressure		Min. Burst Pressure		Min. Bend Radius		Weight	
	DN	mm	in	mm	in	bar	psi	bar	psi	mm	in	kg/m	lbs/ft
<b>GH435-6</b>	10	9.5	0.37	19.0	0.75	490	7,105	1,960	28,420	180	7.09	0.65	0.44
<b>GH435-8</b>	12	12.7	0.50	21.5	0.85	420	6,090	1,680	24,360	230	9.06	0.80	0.54
<b>GH435-10</b>	16	15.9	0.62	25.4	1.00	400	5,800	1,600	23,200	250	9.84	0.95	0.64
<b>GH435-12</b>	19	19.0	0.74	28.8	1.13	380	5,510	1,520	22,040	300	11.81	1.28	0.86
<b>GH435-16</b>	25	25.4	1.00	35.4	1.39	320	4,640	1,280	18,560	340	13.39	1.55	1.04

## Premium hose



Ultra-abrasion



# GH681B

Core premium Bruiser ultra-abrasion one wire braided hose

Meets or exceeds: SAE 100R17 | EN 857 Type 1SC | ISO 1436 1SN | ISO 18752

	<b>GH681B-4</b>	6.4 MM (0.25 IN) DN6	<b>Bruiser</b>	Exceeds SAE 100R17 / EN 857 1SC Performance ISO 1436 1SN • MSHA IC-84/54 • DNV	<b>255 BAR (3700 PSI)</b>	-40°C to +126°C -40°F to +260°F	1A
--	-----------------	-------------------------	----------------	---	---------------------------	------------------------------------	----

### Typical application:

Low and medium pressure hydraulic systems with petroleum and water-based fluids, construction equipment and agriculture equipment, industrial hydraulic systems. For applications where surpassing the 1SC standard is needed. Qualified to one million impulse cycles. With Bruiser cover this hose offers seven hundred times higher abrasion resistance for challenging applications.

**Agency specifications:** MSHA | ABS | DNV

<b>Hose construction:</b>	<b>Inner Tube:</b> Synth. (NBR) rubber tube	<b>Reinforcement:</b> One wire braid	<b>Cover:</b> Bruiser ultra-abrasion
---------------------------	--	---	---

**Operating temperature:** -46°C to +126°C (-50°F to +260°F)

**Qualified fittings:** 1A (-4 to -32) | 1R (-4 -6 -8 -12 -16)

PART #	SIZE DIMENSIONS					PRESSURE				BEND		WEIGHT	
	Hose I.D.			Hose O.D. (nominal)		Working Pressure		Min. Burst Pressure		Min. Bend Radius		Weight	
	DN	mm	in	mm	in	bar	psi	bar	psi	mm	in	kg/m	lbs/ft
<b>GH681B-3</b>	5	4.8	0.19	10.9	0.43	250	3,650	1,000	14,500	45	1.77	0.16	0.11
<b>GH681B-4</b>	6	6.4	0.25	12.9	0.51	255	3,700	1,020	14,800	50	1.97	0.21	0.14
<b>GH681B-5</b>	8	7.9	0.31	14.1	0.55	225	3,250	900	13,000	55	2.17	0.23	0.15
<b>GH681B-6</b>	10	9.5	0.38	16.3	0.64	235	3,400	940	13,600	63	2.48	0.31	0.21
<b>GH681B-8</b>	12	12.7	0.50	19.9	0.78	221	3,200	883	12,800	90	3.54	0.46	0.31
<b>GH681B-10</b>	16	15.9	0.62	22.3	0.88	140	2,025	559	8,100	100	3.94	0.44	0.30
<b>GH681B-12</b>	19	19.0	0.75	26.0	1.02	138	2,000	552	8,000	120	4.72	0.61	0.41
<b>GH681B-16</b>	25	25.4	1.00	34.0	1.34	103	1,500	414	6,000	150	5.91	0.88	0.59
<b>GH681B-20</b>	31	31.8	1.25	41.5	1.63	69	1,000	276	4,000	210	8.27	1.04	0.70
<b>GH681B-24</b>	38	38.1	1.50	47.9	1.89	52	750	207	3,000	250	9.84	1.28	0.86
<b>GH681B-32</b>	51	50.8	2.00	64.0	2.52	41	600	166	2,400	315	12.40	2.20	1.48



# EC881B

Core premium Bruiser Dynamax ultra-performance ultra-abrasion two wire braided hose

Exceeds: SAE 100R16 Type S | EN 857 2SC | ISO 18752



**EC881B-6**
 9.5 MM (0.38 IN) DN10
   
 Bruiser Dynamax
   
 Exceeds SAE 100R16 / 100R19 / EN857 2SC ISO 18752 - DNV - MSHA IC-84/54
   
 400 BAR (5800 PSI)
   
 -40°C to +126°C (-40°F to +260°F)
   
 1/3 Bend 1A

### Typical application:

This Dynamax ultra-performance hose with the Danfoss Dura-Pulse inner tube combines the lightweight flexibility of a two-wire braided hose with the pressure and performance of spiral 100R12 hoses (-16 and smaller). Extra demanding applications requiring high performance EC881 offers one million impulse cycle performance and 1/3 SAE bend radius. With Bruiser cover this hose offers seven hundred times higher abrasion resistance for challenging applications.

### Agency specifications:

MSHA | DNV

<b>Hose construction:</b>	<b>Inner Tube:</b>	<b>Reinforcement:</b>	<b>Cover:</b>
	Dura-Pulse™ patented tube	Two wire braid	Bruiser ultra-abrasion
<b>Operating temperature:</b>	-40°C to +126°C (-40°F to +260°F) for petroleum based hyd. fluids -40° C to +70° C (-40°F to +158° F) for water-based hyd. fluids 0° C to +70° C (+32°F to 158° F) for water		

### Qualified fittings:

1A (-4 to -32)

PART #	SIZE DIMENSIONS					PRESSURE				BEND		WEIGHT	
	Hose I.D.			Hose O.D. (nominal)		Working Pressure		Min. Burst pressure		Min. Bend Radius		Weight	
	DN	mm	in	mm	in	bar	psi	bar	psi	mm	in	kg/m	lbs/ft
<b>EC881B-4</b>	6	6.4	0.25	13.6	0.54	450	6,525	1,800	26,100	33	1.30	0.32	0.22
<b>EC881B-5</b>	8	7.9	0.31	15.4	0.61	400	5,800	1,600	23,200	38	1.50	0.38	0.26
<b>EC881B-6</b>	10	9.5	0.38	17.3	0.68	400	5,800	1,600	23,200	42	1.65	0.43	0.29
<b>EC881B-8</b>	12	12.7	0.50	20.9	0.82	360	5,220	1,440	20,880	60	2.36	0.59	0.40
<b>EC881B-10</b>	16	15.9	0.62	24.0	0.94	350	5,075	1,400	20,300	68	2.68	0.77	0.52
<b>EC881B-12</b>	19	19.0	0.75	27.9	1.10	330	4,785	1,320	19,140	80	3.15	1.04	0.70
<b>EC881B-16</b>	25	25.4	1.00	34.6	1.36	280	4,060	1,120	16,240	150	5.91	1.43	0.96
<b>EC881B-20</b>	31	31.8	1.25	43.4	1.71	172	2,500	688	9,980	210	8.27	1.79	1.20
<b>EC881B-24</b>	38	38.1	1.50	51.8	2.04	138	2,000	552	8,000	250	9.84	1.96	1.32
<b>EC881B-32</b>	51	50.8	2.00	64.0	2.52	110	1,600	440	6,400	315	12.40	2.69	1.81

## Premium hose



Ultra-abrasion

# GH425B

 Core premium Bruiser ultra-abrasion  
four wire spiral hose

**Exceeds:** EN 856 4SP

	GH425B-6	9.5 MM (0.38 IN) DN10	Bruiser	Exceeds EN 856 4SP MSHA IC-84/54 • ABS • DNV	490 BAR (7100 PSI)	-40°C to +100°C -40°F to +212°F	1T
--	----------	--------------------------	---------	---	--------------------	------------------------------------	----

### Typical application:

High pressure hydraulic system service with petroleum and water-base fluids for low temperature applications. Enhanced compatibility for water-based fluids, optimal for mining applications. With Bruiser cover this hose offers seven hundred times higher abrasion resistance for challenging applications.

### Agency specifications:

MSHA | DNV | ABS

### Hose construction:

**Inner tube:** Synthetic rubber

**Reinforcement:** Four wire spiral

**Cover:** Bruiser ultra-abrasion

### Operating temperature:

 -40°C to +100°C (-40°F to +212°F)  
short-term to +120°C (+248°F)

### Qualified fittings:

1T (-6 to -10) | 4S (-12 to -16)

PART #	SIZE DIMENSIONS					PRESSURE				BEND		WEIGHT	
	Hose I.D.			Hose O.D. (nominal)		Working Pressure		Min. Burst Pressure		Min. Bend Radius		Weight	
	DN	mm	in	mm	in	bar	psi	bar	psi	mm	in	kg/m	lbsft
<b>GH425B-6</b>	10	9.5	0.38	20.5	0.81	490	7,100	1,960	28,400	180	7.09	0.70	0.47
<b>GH425B-8</b>	12	12.7	0.50	24.0	0.94	420	6,100	1,680	24,400	230	9.06	0.92	0.62
<b>GH425B-10</b>	16	15.9	0.62	27.9	1.10	420	6,100	1,680	24,400	250	9.84	1.17	0.79
<b>GH425B-12</b>	19	19.0	0.75	32.0	1.26	380	5,500	1,520	22,000	300	11.81	1.52	1.02
<b>GH425B-16</b>	25	25.4	1.00	39.0	1.54	320	4,650	1,280	18,600	340	13.39	1.94	1.30

Winner by Danfoss

# Standard hose



Standard





# Winner

## Ordering information

### Ordering & hose numbering system

#### How to order

Accurate processing and prompt delivery of your order depends on easy identification of your requirements. Please order Aeroquip and Winner brand parts using correct part numbers as described in this guide. Inquiries and orders should be directed to your distributor or:

**Danfoss Distribution II**  
 A/S Nordborgvej 81,  
 6430  
 Nordborg, Denmark  
[www.Danfoss.com/hydraulics](http://www.Danfoss.com/hydraulics)  
 Inside.Sales.DPS.EMEA@  
 danfoss.com

#### Part numbers and dash sizes

Dash size designates the nominal size in 16th of an inch. This number immediately follows the part number and is separated from it with a dash.

#### Dimensions

Dimensions given in this guide for Aeroquip and Winner products are approximate and should be used for reference only. Exact dimensional information for a given product is subject to change and varying tolerances;

contact Danfoss directly for full current information.

#### WARNING

##### Hose assemblies

Danfoss manufactures the terminal ends of our hose fittings to the appropriate requirements established by the SAE or DIN. Therefore, the performance ratings of these hose fittings meet the SAE or DIN requirements. It is possible to order a hose assembly with a fitting terminal end that has a

performance rating lower than the hose rating. When ordering hose assemblies, please keep the connecting end performance rating in mind since this may affect overall hose assembly performance. Hose assembly components (hose and fittings) are easily assembled in the field. However, factory assembled reusable and crimped hose assemblies are available. For complete information, contact Danfoss.

#### Numbering system - hydraulic hose

Depending on the production type, hoses will be bundled in pre-defined hose lengths:

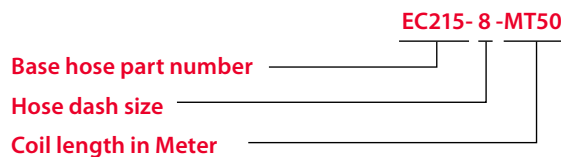











Danfoss is committed to providing pre-defined hose lengths with as few cuts as possible. Nevertheless, please note that following specifications will be valid for the bundled part numbers:

	< MT61	> MT61
<b>Max number of pieces in one bundled coil</b>	Max. 3 pieces	Max. 5 pieces
<b>Shortest length</b>	5 meter	5 meter
<b>Overall length tolerance</b>	+/- 1%	+/- 1%

Core Hose 

# The **standard** hoses

Standard braided hoses		Standard spiral hoses		Standard textile braided hoses	
Hoses	Page	Hoses	Page	Hoses	Page
<b>EC110</b> Standard one wire braided hose	64	<b>EC426</b> Core standard four wire spiral hose	70 	<b>WH005</b> Standard one braided textile hose	75 
<b>EC115</b> Core standard one wire braided hose	65 	<b>EC512</b> Core standard four wire spiral hose	71 	<b>WH006</b> Standard one braided textile hose	76 
<b>EC210</b> Standard two wire braided hose	66	<b>EC420</b> Core standard four and six wire spiral hose	72 	<b>WH007</b> Standard two braided textile hose	77 
<b>EC215</b> Core standard two wire braided hose	67 	<b>EC615</b> Core standard four and six wire spiral hose	73 	<b>Standard speciality hose</b>	
<b>EC118</b> Standard one and two wire braided hose	68	<b>Standard suction hose</b>		<b>EC330</b> Standard three wire braided 4SP performance mining hose	78 
<b>EC082</b> Pilot line one braided hose	69	<b>WH004</b> Core standard suction and return hose	74 		

# Winner

## Standard hose



Standard

# EC110

Standard  
one wire braided hose

Meets: SAE 100R1 | EN 853 1SN

**Winner** by Danfoss **EC110-04** 6.4 MM (0.25 IN) DN6 | SAE 100R1 • EN 853 1SN MSHA IC-84/41 • DNV | **225 BAR (3250 PSI)** -40°C to +100°C (-40°F to +212°F) 1A 2pc

### Typical application:

Hydraulic system service with petroleum and water-based fluids, for general industrial use.

### Agency specifications:

MSHA | DNV

### Hose construction:

**Inner tube:**  
Synthetic rubber

**Reinforcement:**  
One steel braid

**Cover:**  
Synthetic rubber

### Operating temperature:

-40°C to +100°C (-40°F to +212°F), short term up to +120°C (+248°F)

### Qualified fittings:

1A (-4 to 32) | 2-piece Winner (-4 to -32)

PART	SIZE.DIMENSIONS					PRESSURE				BEND		WEIGHT	
	#	Hose I.D.			Hose O.D. (nominal)		Working Pressure		Min. Burst Pressure		Min. Bend Radius		Weight
	DN	mm	in	mm	in	bar	psi	bar	psi	mm	in	kg/m	lbs/ft
<b>EC110-04L</b>	6	6.4	0.25	13.4	0.53	225	3,250	900	13,000	100	3.94	0.22	0.15
<b>EC110-05L</b>	8	7.9	0.31	15.0	0.59	215	3,125	860	12,500	115	4.53	0.26	0.17
<b>EC110-06L</b>	10	9.5	0.38	17.4	0.69	180	2,600	720	10,400	130	5.12	0.33	0.22
<b>EC110-08L</b>	12	12.7	0.50	20.6	0.81	160	2,300	640	9,200	180	7.09	0.41	0.28
<b>EC110-10L</b>	16	15.9	0.62	23.7	0.93	130	1,900	520	7,600	200	7.87	0.47	0.32
<b>EC110-12L</b>	19	19.0	0.75	27.7	1.09	105	1,525	420	6,100	240	9.45	0.59	0.40
<b>EC110-16L</b>	25	25.4	1.00	35.6	1.40	88	1,275	352	5,100	300	11.81	0.87	0.58
<b>EC110-20L</b>	31	31.8	1.25	43.7	1.72	63	925	252	3,700	420	16.54	1.20	0.81
<b>EC110-24L</b>	38	38.1	1.50	50.5	1.99	50	725	200	2,900	500	19.69	1.40	0.94
<b>EC110-32L</b>	51	50.8	2.00	63.8	2.51	40	580	160	2,320	630	24.80	1.91	1.28
<b>EC110-40L*</b>	63	63.5	2.50	76.5	3.01	40	580	200	2,900	762	30.00	2.52	1.69
<b>EC110-48L*</b>	76	76.2	3.00	88.8	3.49	35	508	160	2,320	900	35.43	2.70	1.81

\* Only bulk hose



Standard

# EC115

Core standard  
one wire braided hose

Meets: EN 857 Type 1SC | SAE 100R1

Winner by Danfoss

EC115-08

12.7 MM (0.50 IN)  
DN12

EN857 1SC - MSHA IC-84/41  
DNV-GL - USCG



160 BAR (2300 PSI)

-40°C to +100°C  
-40°F to +212°F

1A 2PC

### Typical application:

Hydraulic system service with petroleum and water-based fluids, for general industrial use.

Agency specifications: MSHA | DNV | USCG

Hose construction:	Inner tube:	Reinforcement:	Cover:
	Synthetic rubber	One wire braid	Synthetic rubber

Operating temperature: -40°C to +100°C (-40°F to +212°F), short term up to +120°C (+248°F)

Qualified fittings: 1A (-4 to 32) | 2-piece Winner (-4 to -32) | 1R (-4 -6 -8 -12 -16)

PART #	SIZE, DIMENSIONS					PRESSURE				BEND		WEIGHT	
	Hose I.D.			Hose O.D. (nominal)		Working Pressure		Min. Burst Pressure		Min. Bend Radius		Weight	
	DN	mm	in	mm	in	bar	psi	bar	psi	mm	in	kg/m	lbs/ft
EC115-04L	6	6.4	0.25	12.6	0.50	225	3,250	900	13,000	50	1.97	0.18	0.12
EC115-05L	8	7.9	0.31	13.8	0.54	215	3,125	860	12,500	55	2.17	0.20	0.13
EC115-06L	10	9.5	0.38	16.1	0.63	180	2,600	720	10,400	63	2.48	0.26	0.17
EC115-08L	12	12.7	0.50	19.5	0.77	160	2,300	640	9,200	90	3.54	0.34	0.23
EC115-10L	16	15.9	0.62	22.3	0.88	130	1,900	520	7,600	100	3.94	0.42	0.28
EC115-12L	19	19.0	0.75	26.0	1.02	105	1,525	420	6,100	120	4.72	0.50	0.34
EC115-16L	25	25.4	1.00	33.9	1.33	88	1,275	352	5,100	160	6.30	0.74	0.50
EC115-20L	31	31.8	1.25	40.9	1.61	63	925	252	3,700	210	8.27	0.99	0.67
EC115-24L	38	38.1	1.50	48.0	1.89	50	725	300	4,350	300	11.81	1.20	0.81
EC115-32L	51	50.8	2.00	61.0	2.40	40	580	220	3,190	400	15.75	1.50	1.01

# Winner

## Standard hose

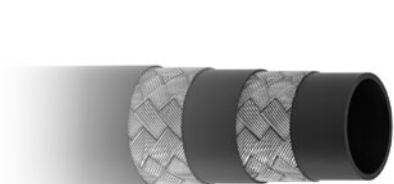

Standard

# EC210

Standard  
two wire braided hose

Meets: SAE 100R2 | EN 853 2SN

**Winner** by Danfoss **EC210-16** 25.4 MM (1.00 IN) DN25 | SAE 100R2 • EN 853 2SN MSHA IC-84/41 • DNV | **165 BAR (2400 PSI)** -40°C to +100°C -40°F to +212°F 1A 2pc

### Typical application:

Hydraulic system service with petroleum and water-based fluids, for general industrial use.

### Agency specifications:

MSHA | DNV

### Hose construction:

**Inner tube:**  
Synthetic rubber

**Reinforcement:**  
Two steel braid

**Cover:**  
Synthetic rubber

### Operating temperature:

-40°C to +100°C (-40°F to +212°F), short term up to +120°C (+248°F)

### Qualified fittings:

1A (-4 to 32) | 2-piece Winner (-4 to -32)

PART #	SIZE DIMENSIONS					PRESSURE				BEND		WEIGHT	
	Hose I.D.			Hose O.D. (nominal)		Working Pressure		Min. Burst Pressure		Min. Bend Radius		Weight	
	DN	mm	in	mm	in	bar	psi	bar	psi	mm	in	kg/m	lbsft
<b>EC210-04L</b>	6	6.4	0.25	15.1	0.59	400	5,800	1,600	23,200	100	3.94	0.38	0.26
<b>EC210-05L</b>	8	7.9	0.31	16.7	0.66	350	5,100	1,400	20,400	115	4.53	0.43	0.29
<b>EC210-06L</b>	10	9.5	0.38	19.0	0.75	330	4,800	1,320	19,200	125	4.92	0.54	0.36
<b>EC210-08L</b>	12	12.7	0.50	22.2	0.88	275	4,000	1,100	16,000	180	7.09	0.64	0.43
<b>EC210-10L</b>	16	15.9	0.62	25.4	1.00	250	3,650	1,000	14,600	200	7.87	0.75	0.50
<b>EC210-12L</b>	19	19.0	0.75	29.4	1.16	215	3,100	860	12,500	240	9.45	0.93	0.62
<b>EC210-16L</b>	25	25.4	1.00	37.7	1.48	165	2,400	660	9,600	300	11.81	1.29	0.87
<b>EC210-20L</b>	31	31.8	1.25	48.0	1.89	125	1,800	500	7,200	420	16.54	1.89	1.27
<b>EC210-24L</b>	38	38.1	1.50	54.3	2.14	90	1,300	360	5,200	500	19.69	2.10	1.41
<b>EC210-32L</b>	51	50.8	2.00	66.9	2.63	80	1,150	320	4,600	630	24.80	2.76	1.85
<b>EC210-40L*</b>	63	63.5	2.50	79.8	3.14	69	1,000	300	4,350	760	29.92	3.80	2.55
<b>EC210-48L*</b>	76	76.2	3.00	91.8	3.61	50	725	240	3,500	900	35.43	4.03	2.71

\* Only bulk hose



# EC215

Core standard  
two wire braided hose

Meets: EN 857 Type 2SC | ISO 18752

**Winner** by Danfoss **EC215-06** 9.5 mm (0.38 in) DN10 | EN857 2SC • ISO 18752 MSHA IC-84/41 • DNV-GL • USCG + | **345 BAR (5000 PSI)** | -40°C to +100°C (-40°F to +212°F) | Half Bend | 1A 2PC

**Typical application:**

Hydraulic system service with petroleum and water-based fluids, for general industrial use.

**Agency specifications:** MSHA | DNV | USCG

<b>Hose construction:</b>	<b>Inner tube:</b>	<b>Reinforcement:</b>	<b>Cover:</b>
	Synthetic rubber	Two wire braid	Synthetic rubber

**Operating temperature:** -40°C to +100°C (-40°F to +212°F), short term up to +120°C (+248°F)

**Qualified fittings:** 1A (-4 to 32) | 2-piece Winner (-4 to -32) | 2R (-4 -6 -8 -12 -16)

PART #	SIZE DIMENSIONS					PRESSURE				BEND		WEIGHT	
	Hose I.D.			Hose O.D. (nominal)		Working Pressure		Min. Burst Pressure		Min. Bend Radius		Weight	
	DN	mm	in	mm	in	bar	psi	bar	psi	mm	in	kg/m	lbsft
<b>EC215-04L</b>	6	6.4	0.25	13.5	0.53	400	5,800	1,600	23,200	50	1.97	0.28	0.19
<b>EC215-05L</b>	8	7.9	0.31	15.3	0.60	350	5,100	1,400	20,400	55	2.17	0.33	0.22
<b>EC215-06L</b>	10	9.5	0.38	17.5	0.69	345	5,000	1,380	20,000	65	2.56	0.41	0.28
<b>EC215-08L</b>	12	12.7	0.50	20.8	0.82	275	4,000	1,100	16,000	90	3.54	0.57	0.38
<b>EC215-10L</b>	16	15.9	0.62	24.0	0.94	250	3,650	1,000	14,600	100	3.94	0.68	0.46
<b>EC215-12L</b>	19	19.0	0.75	27.9	1.10	215	3,125	860	12,500	120	4.72	0.81	0.54
<b>EC215-16L</b>	25	25.4	1.00	35.7	1.40	165	2,400	660	9,600	160	6.30	1.17	0.79
<b>EC215-20L</b>	31	31.8	1.25	43.9	1.73	125	1,800	500	7,200	250	9.84	1.56	1.05
<b>EC215-24L</b>	38	38.1	1.50	51.0	2.01	100	1,450	400	5,800	300	11.81	1.81	1.22
<b>EC215-32L</b>	51	50.8	2.00	63.4	2.50	90	1,300	380	5,500	400	15.75	2.36	1.59



# Winner

## Standard hose



# EC118

Standard  
one and two wire braided hose

Meets: SAE 100R17 | ISO 18752

**Winner** by Danfoss **EC118-08** 12.7 mm (0.50 in) DN12 SAE 100R17 - ISO 18752 MSHA IC-84/41 - USCG **210 BAR (3050 PSI)** -40°C to +100°C -40°F to +212°F 1A 2PC

### Typical application:

EC118 (15C) is a 210 bar constant pressure hydraulic hose for low and medium pressure hydraulic systems with petroleum and water-based fluids.

### Agency specifications:

MSHA | USCG

### Hose construction:

**Inner tube:**  
Synthetic rubber

**Reinforcement:**  
One wire braid: -4, -6, -8  
Two wire braid: -10, -12, -16

**Cover:**  
Synthetic rubber

### Operating temperature:

-40°C to +100°C (-40°F to +212°F), short term up to +120°C (+248°F)

### Qualified fittings:

1A (-4 -6 -8 -10 -12 -16) | 2-piece Winner (-4 -6 -8 -10 -12 -16)

PART #	SIZE DIMENSIONS					PRESSURE				BEND		WEIGHT	
	Hose I.D.			Hose O.D. (nominal)		Working Pressure		Min. Burst Pressure		Min. Bend Radius		Weight	
	DN	mm	in	mm	in	bar	psi	bar	psi	mm	in	kg/m	lbsft
<b>EC118-04L</b>	6	6.4	0.25	12.5	0.49	210	3,050	840	12,200	50	1.97	0.18	0.12
<b>EC118-05L</b>	8	7.9	0.31	14.1	0.55	210	3,050	840	12,200	55	2.17	0.20	0.13
<b>EC118-06L</b>	10	9.5	0.38	16.1	0.63	210	3,050	840	12,200	65	2.56	0.27	0.18
<b>EC118-08L</b>	12	12.7	0.50	19.9	0.78	210	3,050	840	12,200	90	3.54	0.36	0.24
<b>EC118-10L</b>	16	15.9	0.62	24.6	0.97	210	3,050	840	12,200	100	3.94	0.69	0.46
<b>EC118-12L</b>	19	19.0	0.75	28.8	1.13	210	3,050	840	12,200	120	4.72	0.81	0.54
<b>EC118-16L</b>	25	25.4	1.00	37.1	1.46	210	3,050	840	12,200	150	5.91	1.21	0.81



Standard

# EC082

Pilot line  
one braided hose

Winner by Danfoss EC082-04 6.4 MM (0.25 IN) DN6 MSHA IC-84/41 150 BAR (2175 PSI) -40°C to +100°C

**Typical application:**

EC082 is a one wire braided flexible hose designed for pilot lines. General application includes hydraulic system service with petroleum and water-based fluids, for general industrial use.

**Agency specifications:**

MSHA

**Hose construction:**

**Inner tube:**

Synthetic rubber

**Reinforcement:**

One steel braid

**Cover:**

Synthetic rubber

**Operating temperature:**

-40°C to +100°C (-40°F to +212°F)

**Qualified fittings:**

2-piece Winner (00110-04FEWZD, 00110-06EEWZD)

PART #	SIZE DIMENSIONS					PRESSURE				BEND		WEIGHT	
	Hose I.D.			Hose O.D. (nominal)		Working Pressure	Min. Burst Pressure		Min. Bend Radius		Weight		
	DN	mm	in	mm	in	bar	psi	bar	psi	mm	in	kg/m	lbsft
<b>EC082-04</b>	6	6.4	0.25	11.5	0.45	150	2,175	600	8,700	25	0.98	0.15	0.10
<b>EC082-06</b>	10	9.5	0.38	14.8	0.58	120	1,750	480	7,000	40	1.57	0.20	0.13

# Winner

## Standard hose



Standard

# EC426

Core standard  
four wire spiral hose

Meets: EN856 4SP

**Winner** by Danfoss **EC426-12**
19 mm (0.75 in)  
DN19EN856 4SP  
MSHA IC-84/41
 **350 BAR (5100 PSI)**

 -40°C to +100°C  
-40°F to +212°F

 **4S**

### Typical application:

Hydraulic systems service with petroleum and water-based fluids, for general use.

**Agency specifications:** MSHA

Hose construction:	Inner tube:	Reinforcement:	Cover:
Synthetic rubber	Synthetic rubber	Four wire spiral	Synthetic rubber

**Operating temperature:** -40°C to +100°C (-40°F to +212°F), short term up to +125°C (+257°F)

**Qualified fittings:** 1T (-6 to -10) | 4S (-12 to -20) | 2-piece Winner (-6 -8 -10 -12 -16)

PART #	SIZE DIMENSIONS					PRESSURE				BEND		WEIGHT	
	Hose I.D.			Hose O.D. (nominal)		Working Pressure		Min. Burst Pressure		Min. Bend Radius		Weight	
	DN	mm	in	mm	in	bar	psi	bar	psi	mm	in	kg/m	lbsft
<b>EC426-06</b>	10	9.5	0.38	20.5	0.81	445	6,450	1,780	25,800	180	7.09	0.74	0.50
<b>EC426-08</b>	12	12.7	0.50	24.3	0.96	415	6,000	1,660	24,000	230	9.06	0.88	0.59
<b>EC426-10</b>	16	15.9	0.62	28.2	1.11	350	5,100	1,400	20,400	250	9.84	1.04	0.70
<b>EC426-12</b>	19	19.0	0.75	32.2	1.27	350	5,100	1,400	20,400	300	11.81	1.47	0.99
<b>EC426-16</b>	25	25.4	1.00	39.7	1.56	280	4,050	1,120	16,200	340	13.39	1.90	1.28
<b>EC426-20</b>	31	31.8	1.25	47.0	1.85	210	3,050	840	12,200	460	18.11	2.46	1.65



# EC512

Core standard  
four wire spiral hose

Meets: EN 856 Type 4SH

**Winner** by Danfoss **EC512-16** 25.4 MM (1.00 IN) DN25 | EN856 4SH MSHA IC-84/41 · DNV | **380 BAR (5500 PSI)** -40°C to +100°C -40°F to +212°F **4S**

### Typical application:

Hydraulic systems service with petroleum and water-based fluids, for general use.

**Agency specifications:** MSHA | DNV

Hose construction:	Inner tube:	Reinforcement:	Cover:
Synthetic rubber	Synthetic rubber	Four wire spiral	Synthetic rubber

**Operating temperature:** -40°C to +100°C (-40°F to +212°F), short term up to +121°C (+250°F)

**Qualified fittings:** 4S (-12 to -32)

PART #	SIZE DIMENSIONS					PRESSURE				BEND		WEIGHT	
	Hose I.D.			Hose O.D. (nominal)		Working Pressure		Min. Burst Pressure		Min. Bend Radius		Weight	
	DN	mm	in	mm	in	bar	psi	bar	psi	mm	in	kg/m	lbsft
<b>EC512-12</b>	19	19.0	0.75	32.2	1.27	420	6,100	1,680	24,400	280	11.02	1.47	0.99
<b>EC512-16</b>	25	25.4	1.00	38.7	1.52	380	5,500	1,520	22,000	340	13.39	2.04	1.37
<b>EC512-20</b>	31	31.8	1.25	45.5	1.79	350	5,100	1,400	20,400	460	18.11	2.39	1.61
<b>EC512-24</b>	38	38.1	1.50	53.5	2.11	290	4,200	1,160	16,800	560	22.05	3.19	2.14
<b>EC512-32</b>	51	50.8	2.00	68.1	2.68	250	3,650	1,000	14,600	700	27.56	4.37	2.94

# Winner

## Standard hose

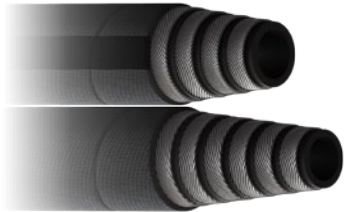

# EC420

Core standard  
four and six wire spiral hose

Meets or exceeds: SAE 100R13 | EN 856 R13 | ISO 18752

**Winner** by Danfoss **EC420-12** 19 mm (0.75 in) DN11 SAE 100R13 • EN856 R13 • ISO 18752 DNV • MSHA IC-84/41 • USCG 350 BAR (5100 PSI) -40°C to +121°C -40°F to +250°F Half Bend 4S

### Typical application:

Suitable for use in hydraulic systems with high peak pressures and arduous operating conditions. Hydraulic systems service with petroleum and water-based fluids, for general use.

### Agency specifications:

MSHA | USCG | DNV

### Hose construction:

Inner tube:	Reinforcement:	Cover:
Synthetic rubber	Four wire spiral (-12, -16) Six wire spiral (-20 to -32)	Synthetic rubber

### Operating temperature:

-40°C to +121°C (-40°F to +250°F)

### Qualified fittings:

4S (-12 to -16) | 6S (-20 to -32)

PART #	SIZE DIMENSIONS					PRESSURE				BEND		WEIGHT	
	Hose I.D.			Hose O.D. (nominal)		Working Pressure		Min. Burst Pressure		Min. Bend Radius		Weight	
	DN	mm	in	mm	in	bar	psi	bar	psi	mm	in	kg/m	lbsft
<b>EC420-12</b>	19	19.0	0.75	32.1	1.26	350	5,100	1,400	20,400	120	4.72	1.54	1.03
<b>EC420-16</b>	25	25.4	1.00	38.7	1.52	350	5,100	1,400	20,400	150	5.91	2.01	1.35
<b>EC420-20</b>	31	31.8	1.25	49.8	1.96	350	5,100	1,400	20,400	210	8.27	3.78	2.54
<b>EC420-24</b>	38	38.1	1.50	57.3	2.26	350	5,100	1,400	20,400	250	9.84	4.73	3.18
<b>EC420-32</b>	51	50.8	2.00	71.5	2.81	350	5,100	1,400	20,400	315	12.40	7.26	4.88

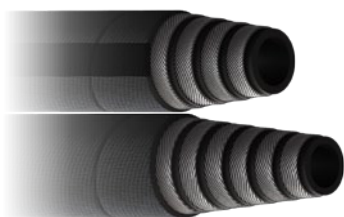

# EC615

Core standard  
four and six wire spiral hose

Meets: SAE 100R15 | EN 856 R13 | ISO 18752

Winner by Danfoss

EC615-16

25.4 MM (1.00 IN)  
DN25

SAE 100R15 • EN 856 R13  
ISO 18752 • MSHA IC-84/41 • DNV

420 BAR (6100 PSI)

-40°C to +121°C  
-40°F to +250°F

4S

### Typical application:

High pressure hydraulic systems with constant high working pressure for use with petroleum and water-glycol based fluids.

Agency specifications: MSHA | DNV

Hose construction:	Inner tube:	Reinforcement:	Cover:
	Synthetic rubber	Four wire and six wire spiral	Synthetic rubber

Operating temperature: -40°C to +121°C (-40°F to +250°F)

Qualified fittings: 4S (-16) | 6S (-20 to -24)

PART #	SIZE DIMENSIONS					PRESSURE				BEND		WEIGHT	
	Hose I.D.			Hose O.D. (nominal)		Working Pressure		Min. Burst Pressure		Min. Bend Radius		Weight	
	DN	mm	in	mm	in	bar	psi	bar	psi	mm	in	kg/m	lbsft
EC615-16	25	25.4	1.00	38.7	1.52	420	6,100	1,680	24,400	150	5.91	2.00	1.35
EC615-20	31	31.8	1.25	49.8	1.96	420	6,100	1,680	24,400	210	8.27	3.77	2.53
EC615-24	38	38.1	1.50	57.3	2.26	420	6,100	1,680	24,400	250	9.84	5.17	3.47
EC615-32*	51	50.8	2.00	71.5	2.81	420	6,100	1,680	24,400	315	12.40	7.26	4.88

\* Only bulk hose



# Winner

## Standard hose

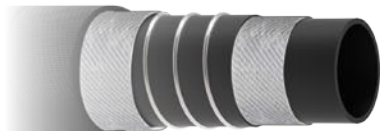

Suction

# WH004

Core standard suction and return hose

Meets or exceeds: SAE 100R4

**Winner** by Danfoss **WH004-12** 19.0 MM (0.75 IN) DN19 | SAE 100R4 MSHA IC-261/5 | **21 BAR (305 PSI)** | -40°C to +100°C (-40°F to +212°F) | 1/3 Bend | 1A-Z 1G • 2pc

### Typical application:

Suitable for use in suction applications for hydraulics, crude fuel, lubricating oils, gasoline, air, water and chemical transfer.

**Agency specifications:** MSHA

<b>Hose construction:</b>	<b>Inner tube:</b> Oil-resistant synthetic rubber	<b>Reinforcement:</b> Textile with helical & anti-static wire	<b>Cover:</b> Synthetic rubber
---------------------------	--	--	-----------------------------------

**Operating temperature:** -40°C to +100°C (-40°F to +212°F)

**Qualified fittings:** 1A (-12 to -32) | 1G (-12 to -32) | 2-piece Winner (-12 to -32) | Socket: 03310-\*

PART #	SIZE DIMENSIONS					PRESSURE				BEND		Vacuum		WEIGHT	
	Hose I.D.			Hose O.D. (nominal)		Working Pressure		Min. Burst Pressure		Min. Bend Radius		Vacuum		Weight	
	DN	mm	in	mm	in	bar	psi	bar	psi	mm	in	kPa	inHg	kg/m	lbsft
<b>WH004-12</b>	19	19.0	0.75	28.6	1.13	21	305	84	1,220	40	1.57	94.8	28	0.54	0.36
<b>WH004-16</b>	25	25.4	1.00	35.2	1.39	17	245	68	980	45	1.77	94.8	28	0.68	0.46
<b>WH004-20</b>	31	31.8	1.25	42.0	1.65	14	205	56	820	60	2.36	94.8	28	0.85	0.57
<b>WH004-24</b>	38	38.1	1.50	49.2	1.94	10.5	150	42	600	65	2.56	94.8	28	1.20	0.81
<b>WH004-32</b>	51	50.8	2.00	62.0	2.44	7	100	28	400	100	3.94	94.8	28	1.53	1.03
<b>WH004-40*</b>	63	63.5	2.50	75.5	2.97	4	60	16	240	140	5.51	94.8	28	2.05	1.38
<b>WH004-48*</b>	76	76.2	3.00	88.0	3.46	4	60	16	240	180	7.09	94.8	28	2.62	1.76

\* Only bulk hose

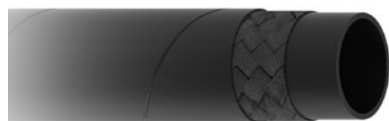

# WH005

Standard  
one braided textile hose

Meets: EN854 1TE | SAE 100R6

**Winner** by Danfoss **WH005-12** 19.0 MM (0.75 IN) DN19 | SAE 100R6 • EN 854 1TE Type MSHA IC-84/41 | **21 BAR (305 PSI)** -40°C to +100°C -40°F to +212°F 2pc

**Typical application:**

For hydraulic control lines; hydraulic systems service with petroleum and water-based fluids for low pressure industrial service.

**Agency specifications:**

MSHA

**Hose construction:**

**Inner tube:**  
Synthetic rubber

**Reinforcement:**  
One synthetic textile braid

**Cover:**  
Synthetic rubber

**Operating temperature:**

-40°C to +100°C (-40°F to +212°F)

**Qualified fittings:**

2-piece Winner (-3 to -16)

PART #	SIZE DIMENSIONS					PRESSURE				BEND		WEIGHT	
	Hose I.D.			Hose O.D. (nominal)		Working Pressure		Min. Burst Pressure		Min. Bend Radius		Weight	
	DN	mm	in	mm	in	bar	psi	bar	psi	mm	in	kg/m	lbsft
<b>WH005-03</b>	5	4.8	0.19	11.6	0.46	35	500	140	2,000	35	1.38	0.09	0.06
<b>WH005-04</b>	6	6.4	0.25	13.2	0.52	28	400	112	1,600	45	1.77	0.11	0.07
<b>WH005-05</b>	8	7.9	0.31	14.7	0.58	28	400	112	1,600	65	2.56	0.13	0.09
<b>WH005-06</b>	10	9.5	0.38	16.3	0.64	28	400	112	1,600	75	2.95	0.15	0.10
<b>WH005-08</b>	12	12.7	0.50	19.7	0.78	28	400	112	1,600	90	3.54	0.19	0.13
<b>WH005-10</b>	16	15.9	0.62	23.9	0.94	24	348	96	1,400	115	4.53	0.26	0.17
<b>WH005-12</b>	19	19.0	0.75	26.4	1.04	21	305	84	1,220	140	5.51	0.32	0.22
<b>WH005-16</b>	25	25.4	1.00	33.8	1.33	20	290	80	1,160	150	5.91	0.42	0.28

# Winner

## Standard hose



# WH006

Standard  
one braided textile hose

Meets: SAE 100R6 | EN854 2TE



**Winner** by Danfoss **WH006-12** 19.0 MM (0.75 IN) DN19 | SAE 100R6 / EN 854 2TE Performance | **45 BAR (655 PSI)** -40°C to +100°C -40°F to +212°F 2pc

### Typical application:

For hydraulic control lines; hydraulic systems service with petroleum and water-based fluids for low pressure industrial service.

### Agency specifications:

MSHA

### Hose construction:

**Inner tube:**  
Synthetic rubber

**Reinforcement:**  
One synthetic textile braid

**Cover:**  
Synthetic rubber

### Operating temperature:

-40°C to +100°C (-40°F to +212°F)

### Qualified fittings:

2-piece Winner (-3 to -16)

PART #	SIZE DIMENSIONS					PRESSURE				BEND		WEIGHT	
	Hose I.D.			Hose O.D. (nominal)		Working Pressure		Min. Burst Pressure		Min. Bend Radius		Weight	
	DN	mm	in	mm	in	bar	psi	bar	psi	mm	in	kg/m	lbsft
<b>WH006-03</b>	5	4.8	0.19	11.8	0.46	80	1,150	320	4,600	35	1.38	0.11	0.08
<b>WH006-04</b>	6	6.4	0.25	13.4	0.53	75	1,100	300	4,400	40	1.57	0.15	0.10
<b>WH006-05</b>	8	7.9	0.31	14.9	0.59	68	1,000	272	4,000	50	1.97	0.17	0.11
<b>WH006-06</b>	10	9.5	0.38	16.5	0.65	63	925	252	3,700	60	2.36	0.18	0.12
<b>WH006-08</b>	12	12.7	0.50	19.7	0.78	58	850	232	3,400	70	2.76	0.24	0.16
<b>WH006-10</b>	16	15.9	0.62	23.9	0.94	50	725	200	2,900	90	3.54	0.26	0.17
<b>WH006-12</b>	19	19.0	0.75	27.0	1.06	45	655	180	2,610	110	4.33	0.39	0.26
<b>WH006-16</b>	25	25.4	1.00	34.4	1.35	40	580	160	2,320	150	5.91	0.57	0.38

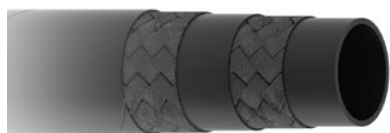

Standard

# WH007

Standard  
two braided textile hose

Meets: EN854 3TE

**Winner** by Danfoss **WH007-12** 19.0 MM (0.75 IN) DN19 | EN 854 3TE MSHA IC-84/55 | **70 BAR (1000 PSI)** 2pc

**Typical application:**

For hydraulic control lines; hydraulic systems service with petroleum and water-based fluids for low pressure industrial service.

**Agency specifications:**

MSHA

**Hose construction:**

**Inner tube:**  
Synthetic rubber

**Reinforcement:**  
Two synthetic textile braid

**Cover:**  
Synthetic rubber

**Operating temperature:**

-40°C to +100°C (-40°F to +212°F)

**Qualified fittings:**

2-piece Winner (-4 to -16)

PART #	SIZE DIMENSIONS					PRESSURE				BEND		WEIGHT	
	Hose I.D.			Hose O.D. (nominal)		Working Pressure		Min. Burst Pressure		Min. Bend Radius		Weight	
	DN	mm	in	mm	in	bar	psi	bar	psi	mm	in	kg/m	lbsft
<b>WH007-04</b>	6	6.4	0.25	14.4	0.57	145	2,100	580	8,400	45	1.77	0.18	0.12
<b>WH007-05</b>	8	7.9	0.31	16.9	0.67	130	1,900	520	7,600	55	2.17	0.25	0.17
<b>WH007-06</b>	10	9.5	0.38	18.5	0.73	110	1,600	440	6,400	70	2.76	0.25	0.17
<b>WH007-08</b>	12	12.7	0.50	21.7	0.85	93	1,350	372	5,400	85	3.35	0.31	0.21
<b>WH007-10</b>	16	15.9	0.62	25.9	1.02	80	1,150	320	4,600	105	4.13	0.45	0.30
<b>WH007-12</b>	19	19.0	0.75	29.0	1.14	70	1,000	280	4,000	130	5.12	0.49	0.33
<b>WH007-16</b>	25	25.4	1.00	35.9	1.41	55	800	220	3,200	150	5.91	0.67	0.45
<b>WH007-20*</b>	31	31.8	1.25	42.3	1.67	45	655	180	2,610	190	7.48	0.78	0.52

\* Only bulk hose

# Winner

## Standard hose



Standard

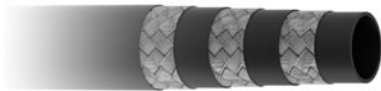

# EC330

Standard  
three wire braided hose

**Winner** by Danfoss

**EC330-12**

 19.0 MM (0.75 IN)  
DN19

MSHA IC-84/41

350 BAR (5100 PSI)

 -40°C to +100°C  
-40°F to +212°F

1T

### Typical application:

Hydraulic system service with petroleum and waterbased fluids, for construction, agriculture equipment and mining. This hose is capable to replace 4SP hoses in some applications.

### Agency specifications:

MSHA

### Hose construction:

**Inner tube:**

Synthetic rubber

**Reinforcement:**

Three wire braid

**Cover:**

Synthetic rubber

### Operating temperature:

-40°C to +100°C (-40°F to +212°F)

### Qualified fittings:

1T (-6 -8 -10) | 4S (-12) | 2-piece Winner (-6 -8 -10 -12)

PART #	SIZE DIMENSIONS					PRESSURE				BEND		WEIGHT	
	Hose I.D.			Hose O.D. (nominal)		Working Pressure		Min. Burst Pressure		Min. Bend Radius		Weight	
	DN	mm	in	mm	in	bar	psi	bar	psi	mm	in	kg/m	lbsft
<b>EC330-06</b>	10	9.5	0.38	19.2	0.76	445	6,450	1,780	25,800	120	4.72	0.81	0.54
<b>EC330-08</b>	12	12.7	0.50	22.4	0.88	415	6,000	1,660	24,000	160	6.30	0.94	0.63
<b>EC330-10</b>	16	15.9	0.62	26.0	1.02	350	5,100	1,400	20,400	210	8.27	1.13	0.76
<b>EC330-12</b>	19	19.0	0.75	29.5	1.16	350	5,100	1,400	20,400	260	10.24	1.49	1.00

Aeroquip by Danfoss

# Braided fittings

1A and 1G series





## Numbering system - hose fittings



**4S12FJ12**

Product group code: **4S**

End connection size: **12**

End connection code: **FJ** (female JIC Swivel)

Hose size: **12**

### Part numbering system

Part numbers collapse to the shortest possible number of digits:

It is assumed that a fitting has a straight configuration unless a code is added to designate otherwise.

e.g., 1A8FJ8 has a straight configuration  
1A8FJA8 has a 45° elbow configuration

Dashes and unnecessary zeros are not used.

e.g., 1/4" is designated by "4" not "-4" or "04"  
5/8" is designated by "10" not "-10"

- 1A = 1A fitting part number
- 4S = 4S fitting part number for four spiral hose
- 6S = 6S fitting part number for six spiral hose
- 1R = Reusable fitting part # for 1 wire braided hose
- 2R = Reusable fitting part # for 2 wire braided hose
- 4T = One piece fitting for Synflex 100R7, 100R8 and 100R18 Thermoplastic hose

#### Material stock code

If material is round stock, then this position collapses.

A = inch hex stock  
(metric hex, this position collapses)

#### End connection size\*

#### End connection code

- BF = BSP Female Swivel (1 hex)
- BP = BSP Male Parallel
- BT = BSP Male Tapered
- CT = Cat Flange
- DK = 24 Male (light duty)
- DL = DKO Female Swivel (light duty)
- DS = DKO Female Swivel (heavy duty)
- EK = 24 Male (heavy duty)
- FH = Flange Code 62
- FJ = Female JIC Swivel
- FL = Flange Code 61
- FR = Female ORS
- FS = Female SAE Swivel
- JF = JIS Female Swivel
- JM = BSP Female Swivel (2 hexes)
- KF = Komatsu Female Swivel
- KS = Komatsu Split Flange
- MB = Male Boss O-Ring
- MF = Male Inverted Flare
- MJ = Male JIC
- MP = Male Pipe
- MR = Male ORS
- PF = Female Pipe Swivel
- PS = Pipe Swivel

#### Connecting end configuration code

If nipple has a straight configuration, then this position collapses.

- A = 45° D = 22-1/2°
- B = 90°, standard or short drop
- C = 90°, long drop
- E = 67-1/2°
- F = 30°
- G = 60°

#### Hose size\*

#### Material Designation

C = stainless steel, if fitting is zinc plated carbon steel (standard), this position collapses.

\*When ordering sizes 3, 4, 5, 6 and 8 the part number requires only single digits.

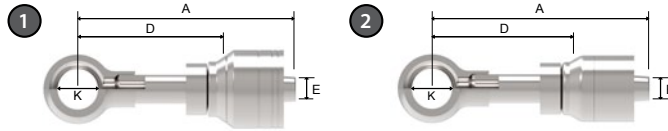

# BJ

Banjo Straight (BJ)

PART		HOSE SIZE INFO		DIMENSIONS							
1	2	Tube O.D.	Hose size	A		D		KØ		EØ	
1A part #	1G part #			mm	in	mm	in	mm	in	mm	in
<b>1A5BJ3</b>	<b>1G5BJ3</b>	6	-03	60.6	2.39	43.0	1.70	10.1	0.40	2.5	0.10
<b>1A6BJ4</b>	<b>1G6BJ4</b>	8	-04	68.8	2.71	45.4	1.79	12.1	0.48	4.2	0.16
<b>1A8BJ5</b>	<b>1G8BJ5</b>	10	-05	71.6	2.82	47.7	1.88	14.1	0.56	5.3	0.21
<b>1A8BJ6</b>	<b>1G8BJ6</b>	10	-06	76.2	3.00	50.9	2.00	14.1	0.56	6.7	0.26
<b>1A10BJ6</b>	<b>1G10BJ6</b>	12	-06	76.9	3.03	51.6	2.03	16.1	0.63	6.7	0.26
<b>1A12BJ6</b>	<b>1G12BJ6</b>	15	-06	83.2	3.28	57.9	2.28	18.1	0.71	6.7	0.26
<b>1A12BJ8</b>	<b>1G12BJ8</b>	15	-08	85.4	3.36	55.7	2.19	18.1	0.71	9.6	0.38
<b>1A16BJ10</b>	<b>1G16BJ10</b>	18	-10	92.5	3.64	63.1	2.48	22.1	0.87	12.8	0.50
<b>1A20BJ12</b>	<b>1G20BJ12</b>	22	-12	95.5	3.76	65.3	2.57	26.1	1.03	15.5	0.61
<b>1A25BJ16</b>	<b>1G25BJ16</b>	28	-16	104.3	4.11	69.9	2.75	30.1	1.18	20.7	0.81

## 1A and 1G TTC braided series

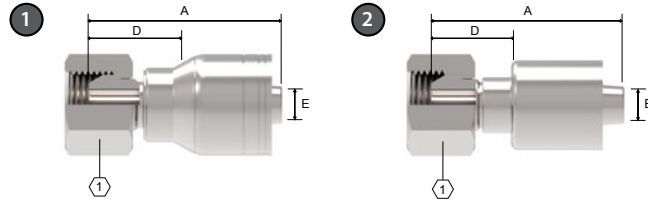

# BF

BSP 60° Cone Female Swivel (BF)

PART		HOSE SIZE INFO			DIMENSIONS							
①	②	Terminal end	Hose size	Thd.	A		D		EØ		①	
1A part #	1G part #				mm	in	mm	in	mm	in	mm	in
1A2BF3	1G2BF3	-02	-03	G 1/8"	33.3	1.31	15.8	0.62	2.5	0.10	14	0.55
1A4BF4	1G4BF4	-04	-04	G 1/4"	42.3	1.67	18.9	0.75	4.2	0.17	17	0.67
1A6BF4	1G6BF4	-06	-04	G 3/8"	45.5	1.79	22.1	0.87	4.2	0.17	22	0.87
1A4BF5	1G4BF5	-04	-05	G 1/4"	45.5	1.79	21.6	0.85	5.3	0.21	17	0.67
1A6BF5	1G6BF5	-06	-05	G 3/8"	46.3	1.82	22.4	0.88	5.3	0.21	22	0.87
1A6BF6	1G6BF6	-06	-06	G 3/8"	46.4	1.83	21.0	0.83	6.7	0.26	22	0.87
1A8BF6	1G8BF6	-08	-06	G 1/2"	47.9	1.89	23.6	0.93	6.7	0.26	27	1.06
1A8BF8	1G8BF8	-08	-08	G 1/2"	53.5	2.11	25.9	1.02	9.6	0.38	27	1.06
1A10BF8	1G10BF8	-10	-08	G 5/8"	56.4	2.22	26.7	1.05	9.6	0.38	30	1.18
1A8BF10	1G8BF10	-08	-10	G 1/2"	55.6	2.19	26.2	1.03	12.8	0.50	27	1.06
1A12BF8	1G12BF8	-12	-08	G 3/4"	56.6	2.23	26.9	1.06	9.6	0.38	32	1.26
1A10BF10	1G10BF10	-10	-10	G 5/8"	54.1	2.13	24.7	0.97	12.8	0.50	27	1.06
1A12BF10	1G12BF10	-12	-10	G 3/4"	56.5	2.22	27.1	1.07	12.8	0.50	32	1.26
1A12BF12	1G12BF12	-12	-12	G 3/4"	55.5	2.19	25.3	1.00	15.5	0.61	32	1.26
1A16BF16	1G16BF16	-16	-16	G 1"	62.0	2.44	30.2	1.19	20.7	0.81	41	1.61
1A20BF20*	1G20BF20	-20	-20	G 1 1/4"	73.6	2.90	29.6	1.17	26.6	1.05	50	1.97
1A24BF24	1G24BF24	-24	-24	G 1 1/2"	81.9	3.22	35.6	1.40	32.0	1.26	55	2.17
1A32BF32	1G32BF32	-32	-32	G 2"	85.4	3.36	33.2	1.31	44.4	1.75	70	2.76

\* one wire

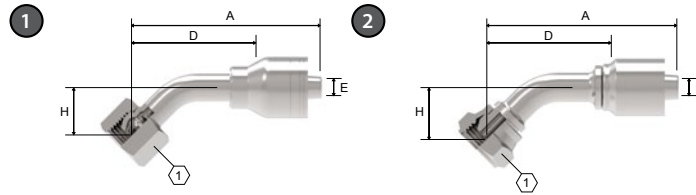

# BFA

BSP 60° Cone Female Swivel - 45° Elbow (BFA)

PART		HOSE SIZE INFO			DIMENSIONS									
1	2	Terminal end	Hose size	Thd.	A		D		EØ		H		1	
1A part #	1G part #				mm	in	mm	in	mm	in	mm	in	mm	in
<b>1A4BFA4</b>	<b>1G4BFA4</b>	-04	-04	G 1/4"	65.3	2.57	41.9	1.65	4.2	0.17	16.5	0.65	17	0.67
<b>1A4BFA5</b>	<b>1G4BFA5</b>	-04	-05	G 1/4"	66.7	2.63	42.8	1.69	5.3	0.21	16.5	0.65	17	0.67
<b>1A6BFA6</b>	<b>1G6BFA6</b>	-06	-06	G 3/8"	73.8	2.91	48.2	1.92	6.2	0.24	19.0	0.75	22	0.87
<b>1A8BFA6</b>	<b>1G8BFA6</b>	-08	-06	G 1/2"	84.7	3.33	59.4	2.34	6.7	0.26	23.5	0.93	27	1.06
<b>1A8BFA8</b>	<b>1G8BFA8</b>	-08	-08	G 1/2"	91.5	3.60	61.7	2.43	9.0	0.35	25.1	0.99	27	1.06
<b>1A10BFA10</b>	<b>1G10BFA10</b>	-10	-10	G 5/8"	100.4	3.95	71.0	2.80	12.8	0.50	27.4	1.08	27	1.06
<b>1A12BFA12</b>	<b>1G12BFA12</b>	-12	-12	G 3/4"	91.3	3.59	61.1	2.41	15.5	0.61	28.4	1.12	32	1.26
<b>1A16BFA16</b>	<b>1G16BFA16</b>	-16	-16	G 1"	126.8	4.99	92.4	3.64	20.7	0.81	33.2	1.31	41	1.61
<b>1A20BFA20*</b>	<b>1G20BFA20</b>	-20	-20	G 1 1/4"	153.5	6.04	109.5	4.31	26.6	1.05	37.2	1.46	50	1.97
<b>1A24BFA24</b>	<b>1G24BFA24</b>	-24	-24	G 1 1/2"	172.9	6.81	126.6	4.98	32.0	1.26	44.1	1.74	55	2.17
<b>1A32BFA32</b>	<b>1G32BFA32</b>	-32	-32	G 2"	211.3	8.32	159.1	6.26	44.4	1.75	52.3	2.06	70	2.76

\* one wire

## 1A and 1G TTC braided series

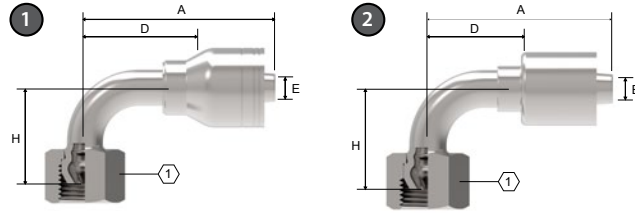

# BFB

BSP 60° Cone Female Swivel - 90° Elbow (BFB)

PART		HOSE SIZE INFO			DIMENSIONS									
①	②	Terminal end	Hose size	Thd.	A		D		EØ		H		①	
1A part #	1G part #				mm	in	mm	in	mm	in	mm	in	mm	in
<b>1A4BFB4</b>	<b>1G4BFB4</b>	-04	-04	G 1/4"	45.8	1.80	22.4	0.88	4.2	0.17	24.8	0.98	17	0.67
<b>1A4BFB5</b>	<b>1G4BFB5</b>	-04	-05	G 1/4"	54.8	2.16	30.9	1.22	5.3	0.21	31.0	1.22	17	0.67
<b>1A6BFB5</b>	<b>1G6BFB5</b>	-06	-05	G 3/8"	60.1	2.37	36.2	1.43	5.3	0.21	35.0	1.38	22	0.87
<b>1A6BFB6</b>	<b>1G6BFB6</b>	-06	-06	G 3/8"	56.9	2.24	31.6	1.24	6.2	0.24	35.0	1.38	22	0.87
<b>1A8BFB6</b>	<b>1G8BFB6</b>	-08	-06	G 1/2"	75.7	2.98	50.4	1.98	6.7	0.26	47.8	1.88	27	1.06
<b>1A8BFB8</b>	<b>1G8BFB8</b>	-08	-08	G 1/2"	68.7	2.70	38.9	1.53	9.6	0.38	37.5	1.48	27	1.06
<b>1A10BFB8</b>	<b>1G10BFB8</b>	-10	-08	G 5/8"	90.7	3.57	61.0	2.40	9.6	0.38	56.3	2.22	27	1.06
<b>1A10BFB10</b>	<b>1G10BFB10</b>	-10	-10	G 5/8"	90.6	3.57	61.2	2.41	12.8	0.50	56.3	2.22	27	1.06
<b>1A12BFB10</b>	<b>1G12BFB10</b>	-12	-10	G 3/4"	93.0	3.66	63.6	2.50	12.8	0.50	60.7	2.39	32	1.26
<b>1A12BFB12</b>	<b>1G12BFB12</b>	-12	-12	G 3/4"	85.4	3.36	55.0	2.17	15.5	0.61	47.5	1.87	32	1.26
<b>1A16BFB16</b>	<b>1G16BFB16</b>	-16	-16	G 1"	107.9	4.25	73.5	2.89	20.7	0.81	60.5	2.38	41	1.61
<b>1A20BFB20*</b>	<b>1G20BFB20</b>	-20	-20	G 1 1/4"	146.2	5.76	102.2	4.02	26.6	1.05	82.5	3.25	50	1.97
<b>1A24BFB24</b>	<b>1G24BFB24</b>	-24	-24	G 1 1/2"	164.0	6.46	117.7	4.63	32.0	1.26	97.1	3.82	55	2.17
<b>1A32BFB32</b>	<b>1G32BFB32</b>	-32	-32	G 2"	202.0	7.95	149.8	5.90	44.4	1.75	121.0	4.76	70	2.76

\* one wire

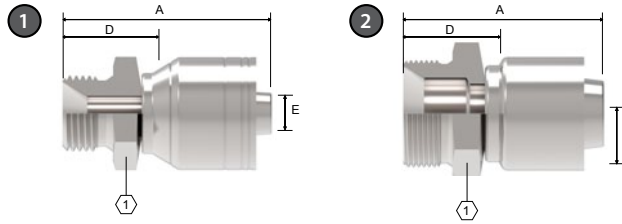

# BP

BSP 60° Cone Male Parallel (BP)

PART		HOSE SIZE INFO			DIMENSIONS							
1	2	Terminal end	Hose size	Thd.	A		D		EØ		1	
1A part #	1G part #				mm	in	mm	in	mm	in	mm	in
<b>1A4BP4</b>	<b>1G4BP4</b>	-04	-04	G 1/4" - 19	44.3	1.74	20.9	0.82	4.2	0.17	19	0.75
<b>1A4BP5</b>	<b>1G4BP5</b>	-04	-05	G 1/4" - 19	45.1	1.78	21.1	0.83	5.3	0.21	19	0.75
<b>1A6BP6</b>	<b>1G6BP6</b>	-06	-06	G 3/8" - 19	48.4	1.91	23.1	0.91	6.7	0.26	22	0.87
<b>1A8BP6</b>	<b>1G8BP6</b>	-08	-06	G 1/2" - 14	52.4	2.06	27.1	1.07	6.7	0.26	27	1.06
<b>1A8BP8</b>	<b>1G8BP8</b>	-08	-08	G 1/2" - 15	58.0	2.28	28.3	1.11	9.6	0.38	27	1.06
<b>1A10BP10</b>	<b>1G10BP10</b>	-10	-10	G 5/8" - 14	61.9	2.44	32.5	1.28	12.8	0.50	30	1.18
<b>1A12BP12</b>	<b>1G12BP12</b>	-12	-12	G 3/4" - 14	63.1	2.48	32.9	1.30	15.5	0.61	32	1.26
<b>1A16BP16</b>	<b>1G16BP16</b>	-16	-16	G 1" - 11	70.9	2.79	36.5	1.44	20.7	0.81	41	1.61
<b>1A20BP20*</b>	<b>1G20BP20</b>	-20	-20	G 1 1/4" - 11	86.2	3.39	42.2	1.66	26.6	1.05	50	1.97
<b>1A24BP24</b>	<b>1G24BP24</b>	-24	-24	G 1 1/2" - 11	92.6	3.65	46.3	1.82	32.0	1.26	55	2.17
<b>1A32BP32</b>	<b>1G32BP32</b>	-32	-32	G 2" - 11	103.6	4.08	53.4	2.10	44.4	1.75	70	2.76

\* one wire

## 1A and 1G TTC braided series

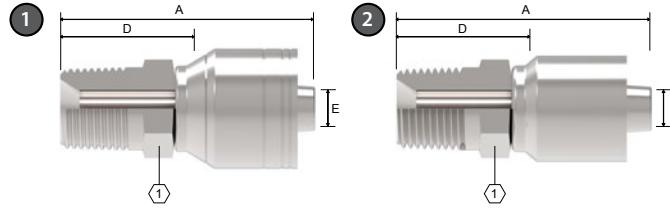

# BT

BSP 60° Cone Male Tapered (BT)

PART		HOSE SIZE INFO			DIMENSIONS							
1	2	Terminal end	Hose size	Thd.	A		D		EØ		1	
1A part #	1G part #				mm	in	mm	in	mm	in	mm	in
1A2BT4	1G2BT4	-02	-04	R 1/8" - 28	46.4	1.83	23.0	0.91	4.2	0.17	14	0.55
1A4BT4	1G4BT4	-04	-04	R 1/4" - 19	50.6	1.99	27.2	1.07	4.2	0.17	14	0.55
1A6BT5	1G6BT5	-06	-05	R 3/8" - 19	52.7	2.07	28.8	1.13	5.3	0.21	19	0.75
1A6BT6	1G6BT6	-06	-06	R 3/8" - 19	54.9	2.16	29.6	1.17	6.7	0.26	19	0.75
1A8BT6	1G8BT6	-08	-06	R 1/2" - 14	62.6	2.46	37.3	1.47	6.7	0.26	22	0.87
1A6BT8	1G6BT8	-06	-08	R 3/8" - 19	60.6	2.39	30.9	1.22	9.6	0.38	22	0.87
1A8BT8	1G8BT8	-08	-08	R 1/2" - 14	66.2	2.61	36.5	1.44	9.6	0.38	22	0.87
1A8BT10	1G8BT10	-08	-10	R 1/2" - 14	67.6	2.66	38.2	1.50	12.8	0.50	24	0.94
1A12BT10	1G12BT10	-12	-10	R 3/4" - 14	70.2	2.76	40.8	1.61	12.8	0.50	27	1.06
1A8BT12	1G8BT12	-08	-12	R 1/2" - 14	69.2	2.72	39.0	1.54	15.5	0.61	30	1.18
1A12BT12	1G12BT12	-12	-12	R 3/4" - 14	71.1	2.80	40.9	1.61	15.5	0.61	30	1.18
1A16BT12	1G16BT12	-16	-12	R 1" - 11	77.0	3.03	46.8	1.84	15.5	0.61	36	1.42
1A12BT16	1G12BT16	-12	-16	R 3/4" - 14	76.4	3.01	42.0	1.65	20.7	0.81	36	1.42
1A16BT16	1G16BT16	-16	-16	R 1" - 11	81.2	3.20	46.8	1.84	20.7	0.81	36	1.42
1A20BT16	1G20BT16	-20	-16	R 1 1/4" - 11	85.4	3.36	51.0	2.01	20.7	0.81	46	1.81
1A16BT20*	1G16BT20	-16	-20	R 1" - 11	95.6	3.76	51.6	2.03	26.6	1.05	46	1.81
1A20BT20*	1G20BT20	-20	-20	R 1 1/4" - 11	96.2	3.79	52.2	2.06	26.6	1.05	46	1.81
1A24BT20*	1G24BT20	-24	-20	R 1 1/2" - 11	98.0	3.86	54.0	2.13	26.6	1.05	50	1.97
1A24BT24	1G24BT24	-24	-24	R 1 1/2" - 11	100.8	3.97	54.5	2.15	32.0	1.26	50	1.97
1A32BT24	1G32BT24	-32	-24	R 2" - 11	106.5	4.19	60.2	2.37	32.0	1.26	65	2.56
1A32BT32	1G32BT32	-32	-32	R 2" - 11	110.4	4.35	60.2	2.37	44.4	1.75	65	2.56

\* one wire



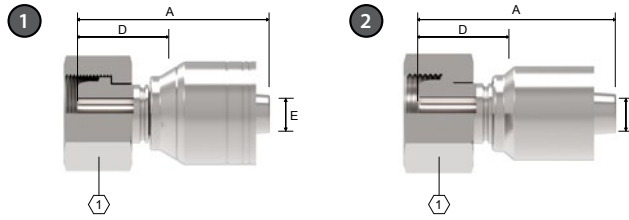

# GG

Gaz Globeseal Female Swivel (GG)

PART		HOSE SIZE INFO			DIMENSIONS							
1	2	Tube O.D.	Hose size	Thd.	A		D		EØ		1	
1A part #	1G part #				mm	in	mm	in	mm	in	mm	in
<b>1A13GG5</b>	<b>1G13GG5</b>	13.25	-05	M20 x 1.5	48.5	1.91	24.6	0.97	5.3	0.21	24	0.94
<b>1A13GG6</b>	<b>1G13GG6</b>	13.25	-06	M20 x 1.5	51.1	2.01	25.8	1.02	6.7	0.26	24	0.94
<b>1A17GG8</b>	<b>1G17GG8</b>	16.75	-08	M24 x 1.5	57.7	2.27	28.0	1.10	9.6	0.38	30	1.18
<b>1A21GG10</b>	<b>1G21GG10</b>	21.25	-10	M30 x 1.5	61.6	2.43	32.2	1.27	12.8	0.50	36	1.42
<b>1A27GG12</b>	<b>1G27GG12</b>	26.75	-12	M36 x 1.5	63.3	2.49	33.1	1.30	15.5	0.61	46	1.81
<b>1A34GG16</b>	<b>1G34GG16</b>	33.50	-16	M45 x 1.5	65.2	2.57	30.8	1.21	20.7	0.81	55	2.17

## 1A and 1G TTC braided series

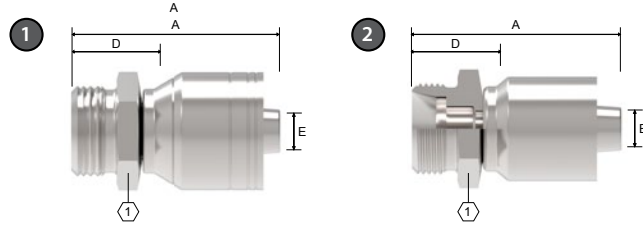

# MG

Gaz Male (MG)

PART		HOSE SIZE INFO			DIMENSIONS							
1	2	Tube O.D.	Hose size	Thd.	A		D		EØ		1	
1A part #	1G part #				mm	in	mm	in	mm	in	mm	in
<b>1A13MG5</b>	<b>1G13MG5</b>	13,25	-05	M20 x 1.5	47.1	1.85	23.2	0.91	5.3	0.21	22	0.87
<b>1A13MG6</b>	<b>1G13MG6</b>	13,25	-06	M20 x 1.5	49.4	1.94	24.1	0.95	6.7	0.26	22	0.87
<b>1A17MG8</b>	<b>1G17MG8</b>	16,75	-08	M24 x 1.5	55.0	2.17	25.3	1.00	9.6	0.38	27	1.06
<b>1A21MG10</b>	<b>1G21MG10</b>	21,25	-10	M30 x 1.5	58.9	2.32	29.5	1.16	12.8	0.50	32	1.26
<b>1A27MG12</b>	<b>1G27MG12</b>	26,75	-12	M36 x 1.5	60.1	2.37	29.9	1.18	15.5	0.61	41	1.61
<b>1A34MG16</b>	<b>1G34MG16</b>	33,50	-16	M45 x 1.5	66.9	2.63	32.5	1.28	20.7	0.81	46	1.81
<b>1A42MG20*</b>	<b>1G42MG20</b>	42,25	-20	M52 x 1.5	80.2	3.16	36.2	1.43	26.6	1.05	55	2.17

\* one wire

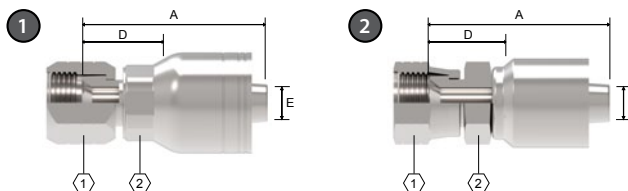

# FJ

JIC 37° Female Swivel (FJ)

PART		HOSE SIZE INFO			DIMENSIONS									
1	2	Terminal end	Hose size	Thd.	A		D		EØ		1		2	
1A part #	1G part #				mm	in	mm	in	mm	in	mm	in	mm	in
<b>1A3FJ3</b>	<b>1G3FJ3</b>	-03	-03	3/8" - 24	40.7	1.60	25.6	1.01	2.5	0.10	14	0.55	11	0.43
<b>1A4FJ3</b>	<b>1G4FJ3</b>	-04	-03	7/16" - 20	40.5	1.59	25.4	1.00	2.5	0.10	14	0.55	11	0.43
<b>1A4FJ4</b>	<b>1G4FJ4</b>	-04	-04	7/16" - 20	48.8	1.92	27.3	1.08	4.2	0.17	14	0.55	14	0.55
<b>1A5FJ4</b>	<b>1G5FJ4</b>	-05	-04	1/2" - 20	50.4	1.98	28.9	1.14	4.2	0.17	17	0.67	14	0.55
<b>1A4FJ5</b>	<b>1G4FJ5</b>	-04	-05	7/16" - 20	49.2	1.94	27.6	1.09	4.4	0.17	14	0.55	14	0.55
<b>1A5FJ5</b>	<b>1G5FJ5</b>	-05	-05	1/2" - 20	50.5	1.99	28.9	1.14	5.3	0.21	17	0.67	14	0.55
<b>1A6FJ5</b>	<b>1G6FJ5</b>	-06	-05	9/16" - 18	53.3	2.10	31.7	1.25	5.3	0.21	17	0.67	17	0.67
<b>1A5FJ6</b>	<b>1G5FJ6</b>	-05	-06	1/2" - 20	52.8	2.08	31.5	1.24	5.9	0.23	17	0.67	17	0.67
<b>1A6FJ6</b>	<b>1G6FJ6</b>	-06	-06	9/16" - 18	53.0	2.09	32.2	1.27	6.7	0.26	17	0.67	17	0.67
<b>1A8FJ6</b>	<b>1G8FJ6</b>	-08	-06	3/4" - 16	54.8	2.16	34.0	1.34	6.7	0.26	22	0.87	17	0.67
<b>1A8FJ8</b>	<b>1G8FJ8</b>	-08	-08	3/4" - 16	63.2	2.49	36.7	1.44	9.6	0.38	22	0.87	22	0.87
<b>1A10FJ8</b>	<b>1G10FJ8</b>	-10	-08	7/8" - 14	65.7	2.59	39.2	1.54	9.6	0.38	27	1.06	22	0.87
<b>1A10FJ10</b>	<b>1G10FJ10</b>	-10	-10	7/8" - 14	66.1	2.60	40.6	1.60	12.8	0.50	27	1.06	24	0.94
<b>1A12FJ10</b>	<b>1G12FJ10</b>	-12	-10	1 1/16" - 12	67.1	2.64	41.4	1.63	12.8	0.50	32	1.26	27	1.06
<b>1A10FJ12</b>	<b>1G10FJ12</b>	-10	-12	7/8" - 14	68.4	2.69	41.3	1.63	12.3	0.48	27	1.06	30	1.18

## 1A and 1G TTC braided series

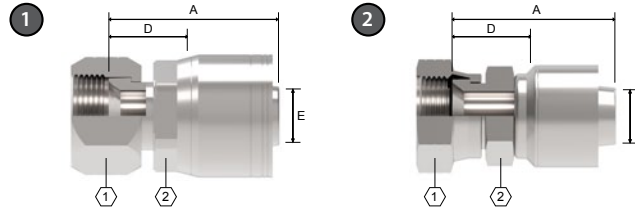

# FJ

JIC 37° Female Swivel (FJ)

PART		HOSE SIZE INFO			DIMENSIONS									
1	2	Terminal end	Hose size	Thd.	A		D		EØ		1		2	
1A part #	1G part #				mm	in	mm	in	mm	in	mm	in	mm	in
<b>1A12FJ12</b>	<b>1G12FJ12</b>	-12	-12	1 1/16" - 12	70.6	2.78	42.1	1.66	15.5	0.61	32	1.26	30	1.18
<b>1A16FJ12</b>	<b>1G16FJ12</b>	-16	-12	1 5/16" - 12	72.8	2.87	45.3	1.78	15.5	0.61	41	1.61	30	1.18
<b>1A12FJ16</b>	<b>1G12FJ16</b>	-12	-16	1 1/16" - 12	79.4	3.13	45.6	1.80	15.5	0.61	32	1.26	36	1.42
<b>1A16FJ16</b>	<b>1G16FJ16</b>	-16	-16	1 5/16" - 12	81.3	3.20	49.1	1.93	20.7	0.82	41	1.61	36	1.42
<b>1A20FJ16</b>	<b>1G20FJ16</b>	-20	-16	1 5/8" - 12	83.7	3.30	51.4	2.02	20.7	0.82	50	1.97	41	1.61
<b>1A20FJ20*</b>	<b>1G20FJ20</b>	-20	-20	1 5/8" - 12	87.3	3.44	47.8	1.88	26.6	1.05	50	1.97	50	1.97
<b>1A24FJ24</b>	<b>1G24FJ24</b>	-24	-24	1 7/8" - 12	96.4	3.80	52.7	2.07	32.0	1.26	60	2.36	60	2.36
<b>1A24FJ32</b>	—	-24	-32	1 7/8" - 12	98.0	3.86	51.8	2.04	33.3	1.31	60	2.36	60	2.36
<b>1A32FJ32</b>	<b>1G32FJ32</b>	-32	-32	2 1/2" - 12	104.3	4.11	58.1	2.29	44.4	1.75	75	2.95	75	2.95

\* one wire

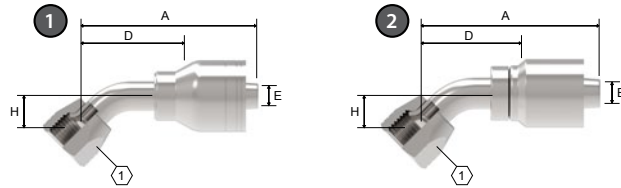

# FJA

JIC 37° Female Swivel - 45° Elbow (FJA)

PART		HOSE SIZE INFO			DIMENSIONS									
①	②	Terminal end	Hose size	Thd.	A		D		EØ		H		①	
1A part #	1G part #				mm	in	mm	in	mm	in	mm	in	mm	in
<b>1A3FJA3</b>	<b>1G3FJA3</b>	-03	-03	3/8" - 24	48,7	1.92	31.2	1.23	2.5	0.10	13.9	0.55	14	0.55
<b>1A4FJA3</b>	<b>1G4FJA3</b>	-04	-03	7/16" - 20	41,3	1.63	26.2	1.03	2.5	0.10	8.4	0.33	14	0.55
<b>1A4FJA4</b>	<b>1G4FJA4</b>	-04	-04	7/16" - 20	41,9	1.65	21.7	0.85	3.9	0.15	8.4	0.33	14	0.55
<b>1A5FJA4</b>	<b>1G5FJA4</b>	-05	-04	1/2" - 20	48,7	1.92	28.5	1.12	4.2	0.17	9.1	0.36	17	0.67
<b>1A5FJA5</b>	<b>1G5FJA5</b>	-05	-05	1/2" - 20	50,4	1.98	28.8	1.13	4.6	0.18	9.1	0.36	17	0.67
<b>1A6FJA5</b>	<b>1G6FJA5</b>	-06	-05	9/16" - 18	51,6	2.03	30.0	1.18	5.3	0.21	9.9	0.39	19	0.75
<b>1A6FJA6</b>	<b>1G6FJA6</b>	-06	-06	9/16" - 18	56,5	2.22	33.3	1.31	6.2	0.24	9.9	0.39	19	0.75
<b>1A8FJA6</b>	<b>1G8FJA6</b>	-08	-06	3/4" - 16	63,4	2.50	42.1	1.66	6.7	0.26	14.0	0.55	22	0.87
<b>1A8FJA8</b>	<b>1G8FJA8</b>	-08	-08	3/4" - 16	71,3	2.81	42.0	1.65	9.4	0.37	14.0	0.55	22	0.87
<b>1A10FJA8</b>	<b>1G10FJA8</b>	-10	-08	7/8" - 14	72,7	2.86	47.2	1.86	9.6	0.38	16.0	0.63	27	1.06
<b>1A10FJA10</b>	<b>1G10FJA10</b>	-10	-10	7/8" - 14	75,2	2.96	45.4	1.79	11.7	0.46	16.0	0.63	27	1.06
<b>1A12FJA10</b>	<b>1G12FJA10</b>	-12	-10	1 1/16" - 12	82,6	3.25	56.5	2.22	12.8	0.50	19.8	0.78	32	1.26
<b>1A12FJA12</b>	<b>1G12FJA12</b>	-12	-12	1 1/16" - 12	88,6	3.49	56.9	2.24	14.8	0.58	19.8	0.78	32	1.26
<b>1A16FJA12</b>	<b>1G16FJA12</b>	-16	-12	1 5/16" - 12	87,2	3.43	60.1	2.37	15.5	0.61	27.1	1.07	41	1.61
<b>1A16FJA16</b>	<b>1G16FJA16</b>	-16	-16	1 5/16" - 12	114,8	4.52	76.4	3.01	20.6	0.81	27.1	1.07	41	1.61
<b>1A20FJA20*</b>	<b>1G20FJA20</b>	-20	-20	1 5/8" - 12	108,4	4.27	68.9	2.71	25.7	1.01	31.0	1.22	50	1.97

\* one wire

## 1A and 1G TTC braided series

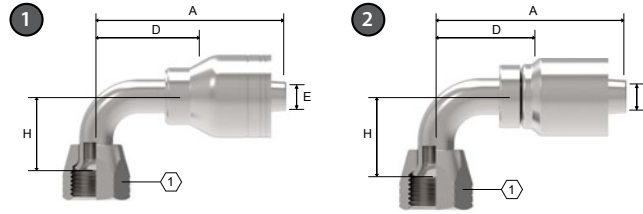

# FJB

JIC 37° Female Swivel - 90° Elbow (FJB)

PART		HOSE SIZE INFO			DIMENSIONS									
1	2	Terminal end	Hose size	Thd.	A		D		EØ		H		1	
1A part #	1G part #				mm	in	mm	in	mm	in	mm	in	mm	in
<b>1A4FJB4</b>	<b>1G4FJB4</b>	-04	-04	7/16" - 20	43.5	1.71	23.3	0.92	3.9	0.15	17.3	0.68	14	0.55
<b>1A5FJB4</b>	<b>1G5FJB4</b>	-05	-04	1/2" - 20	45.5	1.79	25.3	1.00	4.2	0.17	19.6	0.77	17	0.67
<b>1A5FJB5</b>	<b>1G5FJB5</b>	-05	-05	1/2" - 20	47.2	1.86	25.6	1.01	4.6	0.18	19.6	0.77	17	0.67
<b>1A6FJB5</b>	<b>1G6FJB5</b>	-06	-05	9/16" - 18	49.3	1.94	27.7	1.09	5.3	0.21	21.6	0.85	19	0.75
<b>1A6FJB6</b>	<b>1G6FJB6</b>	-06	-06	9/16" - 18	54.1	2.13	30.9	1.22	6.2	0.24	21.6	0.85	19	0.75
<b>1A8FJB6</b>	<b>1G8FJB6</b>	-08	-06	3/4" - 16	57.4	2.26	36.1	1.42	6.7	0.26	27.7	1.09	22	0.87
<b>1A8FJB8</b>	<b>1G8FJB8</b>	-08	-08	3/4" - 16	65.5	2.58	36.0	1.42	9.4	0.37	27.7	1.09	22	0.87
<b>1A10FJB8</b>	<b>1G10FJB8</b>	-10	-08	7/8" - 14	66.5	2.62	41.0	1.61	9.6	0.38	31.2	1.23	27	1.06
<b>1A10FJB10</b>	<b>1G10FJB10</b>	-10	-10	7/8" - 14	69.1	2.72	39.3	1.55	11.7	0.46	31.2	1.23	27	1.06
<b>1A12FJB10</b>	<b>1G12FJB10</b>	-12	-10	1 1/16" - 12	80.9	3.18	54.8	2.16	12.8	0.50	46.2	1.82	32	1.26
<b>1A12FJB12</b>	<b>1G12FJB12</b>	-12	-12	1 1/16" - 12	86.9	3.42	55.2	2.17	14.8	0.58	46.2	1.82	32	1.26
<b>1A16FJB12</b>	<b>1G16FJB12</b>	-16	-12	1 5/16" - 12	82.4	3.24	55.3	2.18	15.5	0.61	60.7	2.39	41	1.61
<b>1A12FJB16</b>	<b>1G12FJB16</b>	-12	-16	1 1/16" - 12	91.5	3.60	57.7	2.27	14.8	0.58	46.2	1.82	32	1.26
<b>1A16FJB16</b>	<b>1G16FJB16</b>	-16	-16	1 5/16" - 12	111.3	4.38	72.9	2.87	20.6	0.81	60.7	2.39	41	1.61
<b>1A20FJB20*</b>	<b>1G20FJB20</b>	-20	-20	1 5/8" - 12	103.5	4.07	64.0	2.52	25.7	1.01	69.8	2.75	50	1.97

\* one wire

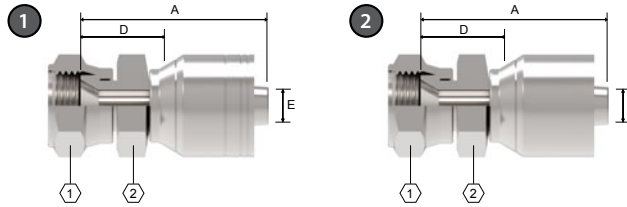

# JF

JIS Female Swivel (JF)

PART		HOSE SIZE INFO			DIMENSIONS									
1	2	Terminal end	Hose size	Thd.	A		D		EØ		1		2	
1A part #	1G part #				mm	in	mm	in	mm	in	mm	in	mm	in
<b>1A4JF4</b>	—	-04	-04	G 1/4"	53.0	2.09	32.8	1.29	4.2	0.17	19	0.75	19	0.75
<b>1A6JF6</b>	—	-06	-06	G 3/8"	55.2	2.17	33.9	1.33	6.7	0.26	22	0.87	22	0.87
<b>1A8JF8</b>	—	-08	-08	G 1/2"	62.6	2.46	37.1	1.46	9.6	0.38	27	1.06	27	1.06
<b>1A12JF12</b>	—	-12	-12	G 3/4"	70.2	2.76	43.1	1.70	15.5	0.61	32	1.26	36	1.42
<b>1A16JF16</b>	—	-16	-16	G 1"	83.0	3.27	49.2	1.94	20.7	0.81	41	1.61	41	1.61
<b>1A20JF20*</b>	—	-20	-20	G 1-1/4"	97.6	3.84	58.1	2.29	26.6	1.05	50	1.97	46	1.81
<b>1A24JF24</b>	—	-24	-24	G 1-1/2"	107.1	4.22	63.4	2.50	32.0	1.26	55	2.17	50	1.97
<b>1A32JF32</b>	—	-32	-32	G 2"	116.6	4.59	70.4	2.77	44.4	1.75	70	2.76	65	2.56

\* one wire



## 1A and 1G TTC braided series

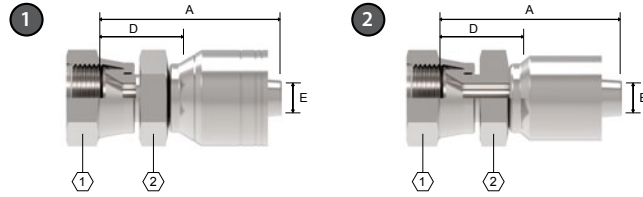

# KF

Komatsu Female Swivel (KF)

PART		HOSE SIZE INFO			DIMENSIONS									
1	2	Terminal end	Hose size	Thd.	A		D		EØ		1		2	
1A part #	1G part #				mm	in	mm	in	mm	in	mm	in	mm	in
<b>1A4KF4</b>	<b>1G4KF4</b>	-04	-04	M14 x 1.5	52.9	2.08	32.7	1.29	42.2	1.66	19	0.75	19	0.75
<b>1A6KF6</b>	<b>1G6KF6</b>	-06	-06	M18 x 1.5	56.4	2.22	35.1	1.38	6.7	0.26	24	0.94	22	0.87
<b>1A8KF8</b>	<b>1G8KF8</b>	-08	-08	M22 x 1.5	65.3	2.57	39.8	1.57	9.6	0.38	27	1.06	27	1.06
<b>1A10KF10</b>	<b>1G10KF10</b>	-10	-10	M24 x 1.5	72.2	2.84	46.0	1.81	12.4	0.49	32	1.25	30	1.18
<b>1A10KF12</b>	<b>1G10KF12</b>	-10	-12	M24 x 1.5	73.6	2.90	46.4	1.83	12.4	0.49	32	1.26	30	1.18
<b>1A12KF12</b>	<b>1G12KF12</b>	-12	-12	M30 x 1.5	78.4	3.09	51.3	2.02	15.5	0.61	36	1.42	36	1.42
<b>1A16KF16</b>	<b>1G16KF16</b>	-16	-16	M33 x 1.5	90.8	3.57	57.0	2.24	20.7	0.81	41	1.61	41	1.61
<b>1A20KF20</b>	<b>1G20KF20</b>	-20	-20	M36 x 1.5	106.5	4.19	67.0	2.64	26.6	1.05	46	1.81	46	1.81
<b>1A24KF24</b>	<b>1G24KF24</b>	-24	-24	M42 x 1.5	115.2	4.54	71.9	2.83	32.0	1.26	55	2.17	50	1.97

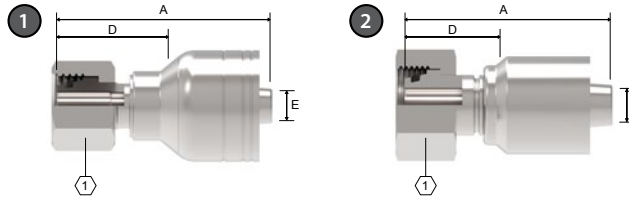

# DL

DIN 24° DKO Light Female Swivel (DL)

PART		HOSE SIZE INFO			DIMENSIONS							
1 1A part #	1G part #	Tube O.D.	Hose size	Thd.	A		D		EØ		1	
					mm	in	mm	in	mm	in	mm	in
<b>1A5DL3</b>	<b>1G5DL3</b>	6	-03	M12 x 1.5	39.7	1.56	22.2	0.87	2.5	0.10	14	0.55
<b>1A5DL4</b>	<b>1G5DL4</b>	6	-04	M12 x 1.5	45.3	1.78	23.4	0.92	4.2	0.17	14	0.55
<b>1A6DL4</b>	<b>1G6DL4</b>	8	-04	M14 x 1.5	46.0	1.81	24.1	0.95	4.2	0.17	17	0.67
<b>1A6DL5</b>	<b>1G6DL5</b>	8	-05	M14 x 1.5	46.2	1.82	22.3	0.88	5.3	0.21	17	0.67
<b>1A8DL4</b>	<b>1G8DL4</b>	10	-04	M16 x 1.5	48.2	1.90	24.8	0.98	4.2	0.17	19	0.75
<b>1A8DL5</b>	<b>1G8DL5</b>	10	-05	M16 x 1.5	50.7	2.00	26.8	1.06	5.3	0.21	19	0.75
<b>1A8DL6</b>	<b>1G8DL6</b>	10	-06	M16 x 1.5	50.5	1.99	25.2	0.99	6.7	0.26	19	0.75
<b>1A10DL6</b>	<b>1G10DL6</b>	12	-06	M18 x 1.5	51.2	2.02	25.9	1.02	6.7	0.26	22	0.87
<b>1A12DL8</b>	<b>1G12DL8</b>	15	-08	M22 x 1.5	58.3	2.30	28.6	1.13	9.6	0.38	27	1.06
<b>1A16DL10</b>	<b>1G16DL10</b>	18	-10	M26 x 1.5	59.2	2.33	29.8	1.17	12.8	0.50	32	1.26
<b>1A20DL12</b>	<b>1G20DL12</b>	22	-12	M30 x 2	62.5	2.46	32.3	1.27	15.5	0.61	36	1.42
<b>1A25DL16</b>	<b>1G25DL16</b>	28	-16	M36 x 2	68.2	2.69	33.8	1.33	20.7	0.81	41	1.61
<b>1A32DL20*</b>	<b>1G32DL20</b>	35	-20	M45 x 2	83.7	3.30	39.7	1.56	26.6	1.05	50	1.97
<b>1A40DL24</b>	<b>1G40DL24</b>	42	-24	M52 x 2	87.2	3.43	40.9	1.61	32.0	1.26	60	2.36

\* one wire

## 1A and 1G TTC braided series

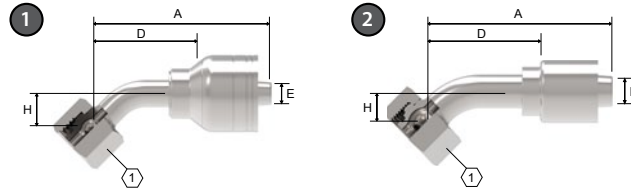

# DLA

DIN 24° DKO Light Female Swivel - 45° Elbow (DLA)

PART		HOSE SIZE INFO			DIMENSIONS									
①	②	Tube O.D.	Hose size	Thd.	A		D		EØ		H		①	
1A part #	1G part #				mm	in	mm	in	mm	in	mm	in	mm	in
<b>1A5DLA3</b>	<b>1G5DLA3</b>	6	-03	M12 x 1.5	52.7	2.07	35.2	1.39	2.5	0.10	15.2	0.60	14	0.55
<b>1A6DLA4</b>	<b>1G6DLA4</b>	8	-04	M14 x 1.5	62.5	2.46	39.1	1.54	4.2	0.17	17.5	0.69	17	0.67
<b>1A8DLA5</b>	<b>1G8DLA5</b>	10	-05	M16 x 1.5	64.9	2.56	41.0	1.61	5.3	0.21	18.5	0.73	19	0.75
<b>1A8DLA6</b>	<b>1G8DLA6</b>	10	-06	M16 x 1.5	66.8	2.63	41.5	1.63	6.7	0.26	19.0	0.75	19	0.75
<b>1A10DLA6</b>	<b>1G10DLA6</b>	12	-06	M18 x 1.5	70.0	2.76	44.7	1.76	6.7	0.26	17.6	0.69	22	0.87
<b>1A12DLA8</b>	<b>1G12DLA8</b>	15	-08	M22 x 1.5	83.0	3.27	53.3	2.10	9.0	0.35	20.6	0.81	27	1.06
<b>1A16DLA10</b>	<b>1G16DLA10</b>	18	-10	M26 x 1.5	91.3	3.59	61.9	2.44	11.7	0.46	22.0	0.87	32	1.26
<b>1A20DLA12</b>	<b>1G20DLA12</b>	22	-12	M30 x 2.0	100.8	3.97	70.6	2.78	14.8	0.58	24.3	0.96	36	1.42
<b>1A25DLA16</b>	<b>1G25DLA16</b>	28	-16	M36 x 2.0	103.1	4.06	68.7	2.70	20.7	0.81	26.7	1.05	41	1.61
<b>1A32DLA20*</b>	<b>1G32DLA20</b>	35	-20	M45 x 2.0	148.0	5.83	104.0	4.09	26.6	1.05	43.0	1.69	50	1.97
<b>1A40DLA24</b>	<b>1G40DLA24</b>	42	-24	M52 x 2.0	180.5	7.11	134.2	5.28	32.0	1.26	52.2	2.06	60	2.36

\* one wire

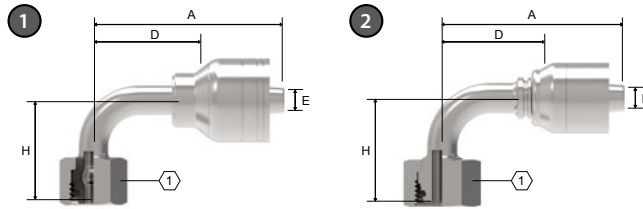

# DLB

DIN 24° DKO Light Female Swivel - 90° Elbow (DLB)

PART		HOSE SIZE INFO			DIMENSIONS									
1	2	Tube O.D.	Hose size	Thd.	A		D		EØ		H		1	
1A part #	1G part #				mm	in	mm	in	mm	in	mm	in	mm	in
<b>1A5DLB3</b>	<b>1G5DLB3</b>	6	-03	M12 x 1.5	42.8	1.69	25.3	1.00	2.5	0.10	26.5	1.04	14	0.55
<b>1A5DLB4</b>	<b>1G5DLB4</b>	6	-04	M12 x 1.5	49.9	1.96	26.5	1.04	4.2	0.17	26.5	1.04	14	0.55
<b>1A6DLB4</b>	<b>1G6DLB4</b>	8	-04	M14 x 1.5	51.2	2.02	27.7	1.09	4.2	0.17	31.0	1.22	17	0.67
<b>1A8DLB5</b>	<b>1G8DLB5</b>	10	-05	M16 x 1.5	55.3	2.18	31.4	1.24	5.3	0.21	35.5	1.40	19	0.75
<b>1A8DLB6</b>	<b>1G8DLB6</b>	10	-06	M16 x 1.5	58.5	2.30	33.6	1.32	6.7	0.26	33.5	1.32	19	0.75
<b>1A10DLB5</b>	<b>1G10DLB5</b>	12	-05	M18 x 1.5	60.1	2.37	36.2	1.43	5.3	0.21	37.5	1.48	22	0.87
<b>1A10DLB6</b>	<b>1G10DLB6</b>	12	-06	M18 x 1.5	59.8	2.35	34.5	1.36	6.7	0.26	34.3	1.35	22	0.87
<b>1A12DLB8</b>	<b>1G12DLB8</b>	15	-08	M22 x 1.5	75.3	2.96	45.6	1.80	9.0	0.35	40.0	1.57	27	1.06
<b>1A16DLB10</b>	<b>1G16DLB10</b>	18	-10	M26 x 1.5	86.4	3.40	57.0	2.24	11.7	0.46	47.0	1.85	32	1.26
<b>1A20DLB12</b>	<b>1G20DLB12</b>	22	-12	M30 x 2.0	94.5	3.72	64.3	2.53	14.8	0.58	51.2	2.02	36	1.42
<b>1A25DLB16</b>	<b>1G25DLB16</b>	28	-16	M36 x 2.0	100.0	3.94	65.6	2.58	20.6	0.81	61.5	2.42	41	1.61
<b>1A32DLB20*</b>	<b>1G32DLB20</b>	35	-20	M45 x 2.0	130.0	5.12	86.0	3.39	26.6	1.05	79.0	3.11	50	1.97
<b>1A40DLB24</b>	<b>1G40DLB24</b>	42	-24	M52 x 2.0	152.0	5.98	105.7	4.16	32.0	1.26	106.0	4.17	60	2.36

\* one wire

## 1A and 1G TTC braided series

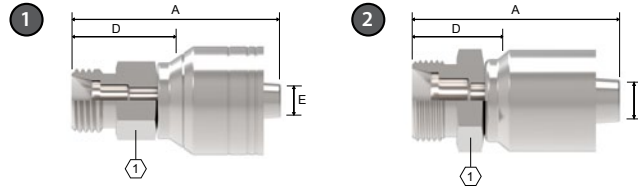

# DK

DIN 24° DKO Light Male (DK)

PART		HOSE SIZE INFO			DIMENSIONS							
1	2	Tube O.D.	Hose size	Thd.	A		D		EØ		1	
1A part #	1G part #				mm	in	mm	in	mm	in	mm	in
<b>1A5DK3</b>	<b>1G5DK3</b>	6	-03	M12 x 1.5	38.0	1.50	21.0	0.83	2.5	0.10	12	0.47
<b>1A5DK4</b>	<b>1G5DK4</b>	6	-04	M12 x 1.5	44.7	1.76	21.3	0.84	4.2	0.17	14	0.55
<b>1A6DK4</b>	<b>1G6DK4</b>	8	-04	M14 x 1.5	44.5	1.75	22.9	0.90	4.2	0.17	14	0.55
<b>1A8DK5</b>	<b>1G8DK5</b>	10	-05	M16 x 1.5	46.8	1.84	23.1	0.91	5.3	0.21	17	0.67
<b>1A8DK6</b>	<b>1G8DK6</b>	10	-06	M16 x 1.5	52.0	2.05	26.7	1.05	6.7	0.26	17	0.67
<b>1A10DK6</b>	<b>1G10DK6</b>	12	-06	M18 x 1.5	49.0	1.93	23.7	0.93	6.7	0.26	19	0.75
<b>1A10DK8</b>	<b>1G10DK8</b>	12	-08	M18 x 1.5	54.5	2.15	24.8	0.97	9.6	0.38	19	0.75
<b>1A12DK8</b>	<b>1G12DK8</b>	15	-08	M22 x 1.5	56.0	2.20	26.3	1.04	9.6	0.38	24	0.94
<b>1A16DK10</b>	<b>1G16DK10</b>	18	-10	M26 x 1.5	56.0	2.20	26.6	1.05	12.8	0.50	27	1.06
<b>1A20DK12</b>	<b>1G20DK12</b>	22	-12	M30 x 2.0	62.0	2.44	31.8	1.25	15.5	0.61	32	1.26
<b>1A25DK16</b>	<b>1G25DK16</b>	28	-16	M36 x 2.0	66.2	2.61	31.8	1.25	20.7	0.81	41	1.61
<b>1A32DK20*</b>	<b>1G32DK20</b>	35	-20	M45 x 2.0	79.4	3.13	35.4	1.39	26.6	1.05	46	1.81
<b>1A40DK24</b>	<b>1G32DK20</b>	42	-24	M52 x 2.0	85.0	3.35	38.8	1.53	32.0	1.26	55	2.17

\* one wire

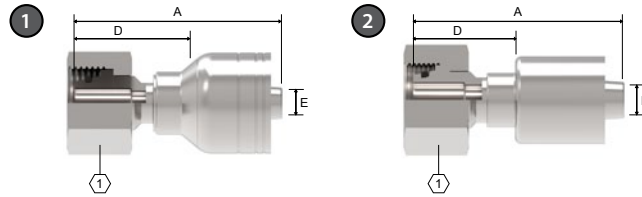

# DS

DIN 24° DKO Heavy Female Swivel (DS)

PART		HOSE SIZE INFO			DIMENSIONS							
1	2	Tube O.D.	Hose size	Thd.	A		D		EØ		1	
1A part #	1G part #				mm	in	mm	in	mm	in	mm	in
<b>1A5DS3</b>	<b>1G5DS3</b>	8	-03	M16 x 1.5	43.4	1.71	25.9	1.02	2.5	0.10	19	0.75
<b>1A5DS4</b>	<b>1G5DS4</b>	8	-04	M16 x 1.5	49.6	1.95	26.2	1.03	4.2	0.17	19	0.75
<b>1A6DS4</b>	<b>1G6DS4</b>	10	-04	M18 x 1.5	50.8	2.00	27.5	1.08	5.3	0.21	22	0.87
<b>1A6DS5</b>	<b>1G6DS5</b>	10	-05	M18 x 1.5	51.4	2.02	27.5	1.08	5.3	0.21	22	0.87
<b>1A8DS5</b>	<b>1G8DS5</b>	12	-05	M20 x 1.5	51.6	2.03	27.7	1.09	5.3	0.21	24	0.94
<b>1A8DS6</b>	<b>1G8DS6</b>	12	-06	M20 x 1.5	53.8	2.12	28.5	1.12	6.7	0.26	24	0.94
<b>1A10DS6</b>	<b>1G10DS6</b>	14	-06	M22 x 1.5	56.9	2.24	31.6	1.24	6.7	0.26	27	1.06
<b>1A10DS8</b>	<b>1G10DS8</b>	14	-08	M22 x 1.5	55.2	2.17	25.5	1.00	9.6	0.38	27	1.06
<b>1A12DS8</b>	<b>1G12DS8</b>	16	-08	M24 x 1.5	62.4	2.46	32.7	1.29	9.6	0.38	30	1.18
<b>1A16DS10</b>	<b>1G16DS10</b>	20	-10	M30 x 2.0	66.9	2.63	37.5	1.48	12.8	0.50	36	1.42
<b>1A20DS12</b>	<b>1G20DS12</b>	25	-12	M36 x 2.0	72.0	2.83	41.8	1.65	15.5	0.61	46	1.81
<b>1A25DS16</b>	<b>1G25DS16</b>	30	-16	M42 x 2.0	78.5	3.09	44.1	1.74	20.7	0.81	50	1.97
<b>1A32DS20*</b>	<b>1G32DS20</b>	38	-20	M52 x 2.0	93.7	3.69	49.7	1.96	26.6	1.05	60	2.36

\* one wire

## 1A and 1G TTC braided series

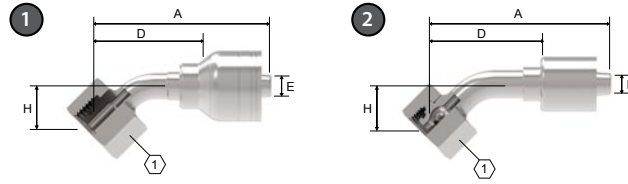

# DSA

DIN 24° DKO Heavy Female Swivel - 45° Elbow (DSA)

PART		HOSE SIZE INFO			DIMENSIONS									
①	②	Tube O.D.	Hose size	Thd.	A		D		EØ		H		①	
1A part #	1G part #				mm	in	mm	in	mm	in	mm	in	mm	in
<b>1A5DSA3</b>	<b>1G5DSA3</b>	8	-03	M16 x 1.5	51.0	2.01	33.5	1.32	2.5	0.10	15.0	0.59	19	0.75
<b>1A6DSA4</b>	<b>1G6DSA4</b>	10	-04	M18 x 1.5	60.1	2.37	36.7	1.44	4.2	0.17	16.8	0.66	22	0.87
<b>1A8DSA5</b>	<b>1G8DSA5</b>	12	-05	M20 x 1.5	62.1	2.44	38.2	1.50	5.3	0.21	17.2	0.68	24	0.94
<b>1A8DSA6</b>	<b>1G8DSA6</b>	12	-06	M20 x 1.5	66.3	2.61	41.0	1.61	6.7	0.26	17.3	0.68	24	0.94
<b>1A10DSA6</b>	<b>1G10DSA6</b>	14	-06	M22 x 1.5	68.8	2.71	43.5	1.71	6.7	0.26	20.0	0.79	27	1.06
<b>1A12DSA8</b>	<b>1G12DSA8</b>	16	-08	M24 x 1.5	86.7	3.41	57.0	2.24	9.6	0.38	24.0	0.94	30	1.18
<b>1A16DSA10</b>	<b>1G16DSA10</b>	20	-10	M30 x 2.0	87.1	3.43	57.7	2.27	12.0	0.47	24.7	0.97	36	1.42
<b>1A20DSA12</b>	<b>1G20DSA12</b>	25	-12	M36 x 2.0	107.4	4.23	77.2	3.04	15.5	0.61	32.5	1.28	46	1.81
<b>1A25DSA16</b>	<b>1G25DSA16</b>	30	-16	M42 x 2.0	121.4	4.78	87.0	3.43	20.7	0.81	37.5	1.48	50	1.97
<b>1A32DSA20*</b>	<b>1G32DSA20</b>	38	-20	M52 x 2.0	171.6	6.76	127.6	5.02	26.6	1.05	45.9	1.81	60	2.36

\* one wire



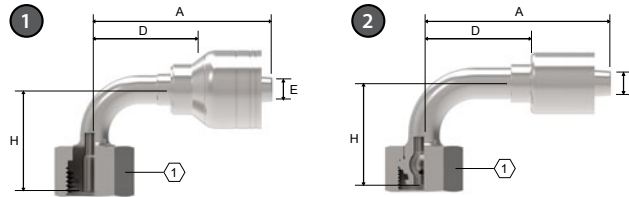

# DSB

DIN 24° DKO Heavy Female Swivel - 90° Elbow (DSB)

PART		HOSE SIZE INFO			DIMENSIONS									
1	2	Tube O.D.	Hose size	Thd.	A		D		EØ		H		1	
1A part #	1G part #				mm	in	mm	in	mm	in	mm	in	mm	in
<b>1A5DSB3</b>	<b>1G5DSB3</b>	8	-03	M16 x 1.5	44.5	1.75	27.0	1.06	2.5	0.10	30.5	1.20	19	0.75
<b>1A5DSB4</b>	<b>1G5DSB4</b>	8	-04	M16 x 1.5	54.0	2.13	30.6	1.20	4.2	0.17	28.6	1.13	19	0.75
<b>1A6DSB4</b>	<b>1G6DSB4</b>	10	-04	M18 x 1.5	54.4	2.14	31.0	1.22	4.2	0.17	33.5	1.32	22	0.87
<b>1A6DSB5</b>	<b>1G6DSB5</b>	10	-05	M18 x 1.5	53.9	2.12	30.0	1.18	5.3	0.21	33.5	1.32	22	0.87
<b>1A8DSB5</b>	<b>1G8DSB5</b>	12	-05	M20 x 1.5	56.9	2.24	33.0	1.30	5.3	0.21	36.5	1.44	24	0.94
<b>1A8DSB6</b>	<b>1G8DSB6</b>	12	-06	M20 x 1.5	59.9	2.36	34.6	1.36	6.7	0.26	35.3	1.39	24	0.94
<b>1A10DSB6</b>	<b>1G10DSB6</b>	14	-06	M22 x 1.5	63.8	2.51	38.5	1.52	6.7	0.26	42.0	1.65	27	1.06
<b>1A12DSB8</b>	<b>1G12DSB8</b>	16	-08	M24 x 1.5	77.7	3.06	48.0	1.89	9.6	0.38	45.3	1.78	30	1.18
<b>1A16DSB10</b>	<b>1G16DSB10</b>	20	-10	M30 x 2.0	82.0	3.23	52.6	2.07	12.8	0.50	52.0	2.05	36	1.42
<b>1A20DSB12</b>	<b>1G20DSB12</b>	25	-12	M36 x 2.0	93.0	3.66	62.8	2.47	15.5	0.61	64.6	2.54	46	1.81
<b>1A25DSB16</b>	<b>1G25DSB16</b>	30	-16	M42 x 2.0	104.0	4.09	69.6	2.74	20.7	0.81	74.0	2.91	50	1.97

## 1A and 1G TTC braided series

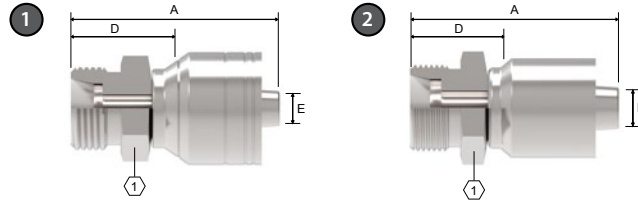

# EK

DIN 24° DKO Heavy Male (EK)

PART		HOSE SIZE INFO			DIMENSIONS							
1	2	Tube O.D.	Hose size	Thd.	A		D		EØ		1	
1A part #	1G part #				mm	in	mm	in	mm	in	mm	in
<b>1A5EK3</b>	<b>1G5EK3</b>	8	-03	M16 x 1.5	41.0	1.61	23.5	0.93	2.5	0.10	17	0.67
<b>1A5EK4</b>	<b>1G5EK4</b>	8	-04	M16 x 1.5	47.5	1.87	24.1	0.95	4.2	0.17	17	0.67
<b>1A6EK4</b>	<b>1G6EK4</b>	10	-04	M18 x 1.5	47.0	1.85	23.6	0.93	4.2	0.17	19	0.75
<b>1A8EK5</b>	<b>1G8EK5</b>	12	-05	M20 x 1.5	48.2	1.90	24.3	0.96	5.3	0.21	22	0.87
<b>1A8EK6</b>	<b>1G8EK6</b>	12	-06	M20 x 1.5	50.3	1.98	25.0	0.98	6.7	0.26	22	0.87
<b>1A10EK6</b>	<b>1G10EK6</b>	14	-06	M22 x 1.5	52.6	2.07	27.3	1.07	6.7	0.26	24	0.94
<b>1A12EK8</b>	<b>1G12EK8</b>	16	-08	M24 x 1.5	58.0	2.28	28.3	1.11	9.6	0.38	27	1.06
<b>1A16EK10</b>	<b>1G16EK10</b>	20	-10	M30 x 2.0	62.0	2.44	32.6	1.28	12.8	0.50	32	1.26
<b>1A20EK12</b>	<b>1G20EK12</b>	25	-12	M36 x 2.0	65.5	2.58	35.3	1.39	15.5	0.61	41	1.61
<b>1A25EK16</b>	<b>1G25EK16</b>	30	-16	M42 x 2.0	72.3	2.85	37.9	1.49	20.7	0.81	46	1.81
<b>1A32EK20*</b>	<b>1G32EK20</b>	38	-20	M52 x 2.0	88.2	3.47	44.2	1.74	26.6	1.05	55	2.17

\* one wire

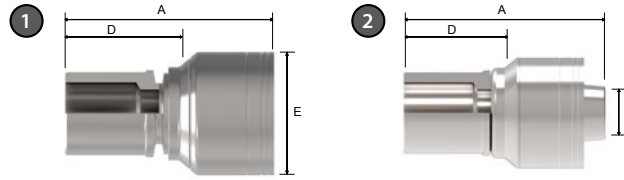

# LG

Gaz Standpipe (LG)

PART		HOSE SIZE INFO			DIMENSIONS					
1	2	Tube O.D.	Hose size	Thd.	A		D		EØ	
1A part #	1G part #				mm	in	mm	in	mm	in
<b>1A13LG5</b>	<b>1G13LG5</b>	8	-05		53.1	2.09	29.2	1.15	5.3	0.21
<b>1A13LG6</b>	<b>1G13LG6</b>	10	-06		55.4	2.18	30.1	1.19	6.7	0.26
<b>1A17LG8</b>	<b>1G17LG8</b>	12	-08		63.9	2.52	34.2	1.35	9.6	0.38
<b>1A21LG10</b>	<b>1G21LG10</b>	16	-10		64.9	2.56	35.5	1.40	12.8	0.50
<b>1A27LG12</b>	<b>1G27LG12</b>	19	-12		66.1	2.60	35.9	1.41	15.5	0.61
<b>1A34LG16</b>	<b>1G34LG16</b>	25	-16		71.9	2.83	37.5	1.48	20.7	0.81
<b>1A42LG20*</b>	<b>1G42LG20</b>	31	-20		89.0	3.50	35.8	1.41	26.6	1.05
<b>1A48LG24</b>	<b>1G48LG24</b>	38	-24		97.2	3.83	51.2	2.02	32.0	1.26

\* one wire

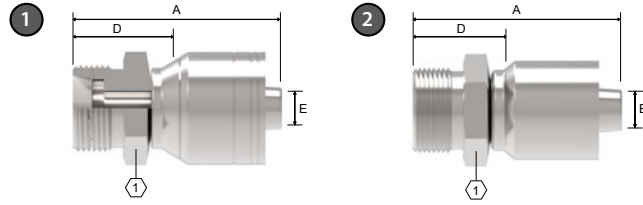
**1A and 1G TTC braided series**

# MM

Millimetric Male (MM)

PART		HOSE SIZE INFO			DIMENSIONS							
1	2	Tube O.D.	Hose size	Thd.	A		D		EØ		1	
1A part #	1G part #				mm	in	mm	in	mm	in	mm	in
<b>1A6MM4</b>	<b>1G6MM4</b>	6	-04	M12 x 1.0	46.3	1.82	22.9	0.90	4.2	0.17	14	0.55
<b>1A8MM4</b>	<b>1G8MM4</b>	8	-04	M14 x 1.5	44.5	1.75	21.1	0.83	4.2	0.17	14	0.55
<b>1A10MM5</b>	<b>1G10MM5</b>	10	-05	M16 x 1.5	47.0	1.85	23.1	0.91	5.3	0.21	17	0.67
<b>1A12MM5</b>	<b>1G12MM5</b>	12	-05	M18 x 1.5	47.1	1.85	23.2	0.91	5.3	0.21	19	0.75
<b>1A12MM6</b>	<b>1G12MM6</b>	12	-06	M18 x 1.5	49.0	1.93	23.7	0.93	6.7	0.26	19	0.75
<b>1A14MM6</b>	<b>1G14MM6</b>	14	-06	M20 x 1.5	49.4	1.94	24.1	0.95	6.7	0.26	22	0.87
<b>1A15MM8</b>	<b>1G15MM8</b>	15	-08	M22 x 1.5	56.0	2.20	26.3	1.04	9.6	0.38	24	0.94
<b>1A16MM8</b>	<b>1G16MM8</b>	16	-08	M24 x 1.5	58.0	2.28	28.3	1.11	9.6	0.38	27	1.06
<b>1A18MM10</b>	<b>1G18MM10</b>	18	-10	M27 x 1.5	58.9	2.32	29.5	1.16	12.8	0.50	30	1.18
<b>1A22MM12</b>	<b>1G22MM12</b>	22	-12	M30 x 1.5	60.1	2.37	29.9	1.18	15.1	0.59	32	1.26
<b>1A25MM12</b>	<b>1G25MM12</b>	25	-12	M33 x 1.5	60.1	2.37	29.9	1.18	15.5	0.61	36	1.42

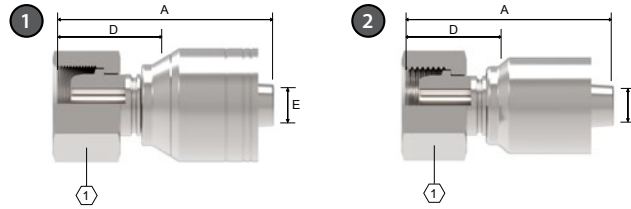

# GM

Millimetrique Globeseal Female Swivel (GM)

PART		HOSE SIZE INFO			DIMENSIONS							
1	2	Tube O.D.	Hose size	Thd.	A		D		EØ		1	
1A part #	1G part #				mm	in	mm	in	mm	in	mm	in
<b>1A6GM4</b>	<b>1G6GM4</b>	6	-04	M12 x 1.0	49.7	1.96	26.3	1.04	4.2	0.17	17	0.67
<b>1A8GM4</b>	<b>1G8GM4</b>	8	-04	M14 x 1.5	47.0	1.85	23.6	0.93	4.2	0.17	17	0.67
<b>1A10GM5</b>	<b>1G10GM5</b>	10	-05	M16 x 1.5	46.6	1.83	22.7	0.89	5.3	0.21	19	0.75
<b>1A12GM5</b>	<b>1G12GM5</b>	12	-05	M18 x 1.5	46.6	1.83	22.7	0.89	5.3	0.21	22	0.87
<b>1A12GM6</b>	<b>1G12GM6</b>	12	-06	M18 x 1.5	49.1	1.93	23.8	0.94	6.7	0.26	22	0.87
<b>1A14GM6</b>	<b>1G14GM6</b>	14	-06	M20 x 1.5	51.3	2.02	26.0	1.02	6.7	0.26	24	0.94
<b>1A15GM8</b>	<b>1G15GM8</b>	15	-08	M22 x 1.5	55.2	2.17	25.5	1.00	9.6	0.38	27	1.06
<b>1A16GM8</b>	<b>1G16GM8</b>	16	-08	M24 x 1.5	59.2	2.33	29.5	1.16	9.6	0.38	30	1.18
<b>1A18GM10</b>	—	18	-10	M27 x 1.5	59.1	2.33	29.7	1.17	12.8	0.50	32	1.26
<b>1A20GM10</b>	<b>1G20GM10</b>	20	-10	M27 x 1.5	57.6	2.27	28.2	1.11	12.8	0.50	32	1.26
<b>1A22GM12</b>	<b>1G22GM12</b>	22	-12	M30 x 1.5	58.3	2.30	28.1	1.11	15.5	0.61	36	1.42
<b>1A25GM12</b>	<b>1G25GM12</b>	25	-12	M33 x 1.5	59.3	2.33	29.1	1.15	15.5	0.61	41	1.61

## 1A and 1G TTC braided series

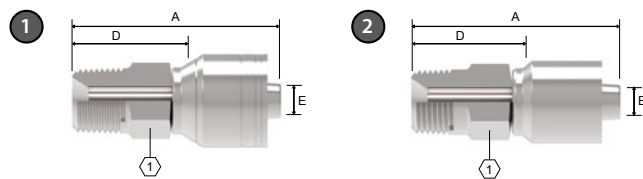

# MP

Male Pipe (MP)

PART		HOSE SIZE INFO			DIMENSIONS							
1	2	Terminal end	Hose size	Thd.	A		D		EØ		1	
1A part #	1G part #				mm	in	mm	in	mm	in	mm	in
<b>1A2MP3</b>	<b>1G2MP3</b>	-02	-03	1/8" - 27	38.0	1.50	22.9	0.90	2.5	0.10	12	0.47
<b>1A2MP4</b>	<b>1G2MP4</b>	-02	-04	1/8" - 27	43.5	1.71	23.3	0.93	4.2	0.17	14	0.55
<b>1A4MP4</b>	<b>1G4MP4</b>	-04	-04	1/4" - 18	49.1	1.93	28.9	1.14	4.2	0.17	17	0.67
<b>1A6MP4</b>	<b>1G6MP4</b>	-06	-04	3/8" - 18	45.0	1.77	24.8	0.98	4.2	0.17	19	0.75
<b>1A4MP5</b>	<b>1G4MP5</b>	-04	-05	1/4" - 18	50.8	2.00	29.2	1.15	5.3	0.21	17	0.67
<b>1A6MP5</b>	<b>1G6MP5</b>	-06	-05	3/8" - 18	53.1	2.09	31.5	1.24	5.3	0.21	19	0.75
<b>1A4MP6</b>	<b>1G4MP6</b>	-04	-06	1/4" - 18	51.4	2.02	30.1	1.18	6.7	0.26	17	0.67
<b>1A6MP6</b>	<b>1G6MP6</b>	-06	-06	3/8" - 18	53.7	2.11	32.4	1.28	6.7	0.26	19	0.75
<b>1A8MP6</b>	<b>1G8MP6</b>	-08	-06	1/2" - 14	53.7	2.11	32.4	1.28	6.7	0.26	22	0.87
<b>1A6MP8</b>	<b>1G6MP8</b>	-06	-08	3/8" - 18	59.1	2.33	33.6	1.32	9.6	0.38	22	0.87
<b>1A8MP8</b>	<b>1G8MP8</b>	-08	-08	1/2" - 14	65.4	2.57	39.9	1.57	9.6	0.38	22	0.87
<b>1A8MP10</b>	<b>1G8MP10</b>	-08	-10	1/2" - 14	66.2	2.61	40.1	1.58	12.8	0.50	24	0.94
<b>1A12MP10</b>	<b>1G12MP10</b>	-12	-10	3/4" - 14	61.7	2.43	35.6	1.40	12.8	0.50	30	1.18
<b>1A8MP12</b>	<b>1G8MP12</b>	-08	-12	1/2" - 14	67.6	2.66	40.5	1.59	14.3	0.56	30	1.18
<b>1A12MP12</b>	<b>1G12MP12</b>	-12	-12	3/4" - 14	68.9	2.71	41.8	1.65	15.5	0.61	30	1.18
<b>1A16MP12</b>	<b>1G16MP12</b>	-16	-12	1 1/2" - 11	67.9	2.67	40.8	1.61	15.5	0.61	36	1.42

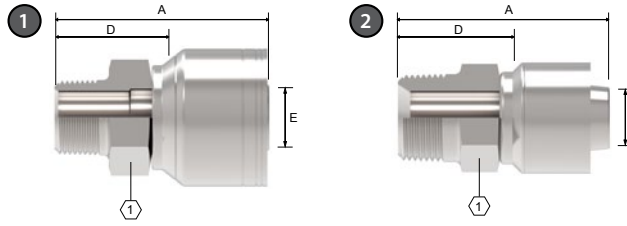

# MP

Male Pipe (MP)

PART		HOSE SIZE INFO			DIMENSIONS							
1	2	Terminal end	Hose size	Thd.	A		D		EØ		1	
1A part #	1G part #				mm	in	mm	in	mm	in	mm	in
<b>1A12MP16</b>	<b>1G12MP16</b>	-12	-16	3/4" - 14	76.2	3.00	42.4	1.67	19.2	0.76	36	1.42
<b>1A16MP16</b>	<b>1G16MP16</b>	-16	-16	1" - 11 1/2	81.1	3.19	47.3	1.86	20.7	0.81	36	1.42
<b>1A20MP20*</b>	<b>1G20MP20</b>	-20	-20	1 1/4" - 11 1/2	84.9	3.34	45.4	1.79	26.6	1.05	46	1.81
<b>1A24MP24</b>	<b>1G24MP24</b>	-24	-24	1 1/2" - 11 1/2	103.7	4.08	60.0	2.36	32.0	1.26	50	1.97
<b>1A32MP32</b>	<b>1G32MP32</b>	-32	-32	2 1/2" - 11	110.5	4.35	64.3	2.53	44.4	1.75	65	2.56

\* one wire



## 1A and 1G TTC braided series

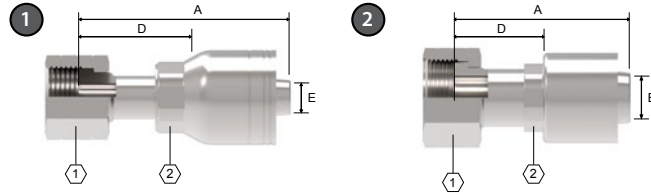

# FR

ORS Female Swivel (FR)

PART		HOSE SIZE INFO			DIMENSIONS									
1	2	Terminal end	Hose size	Thd.	A		D		EØ		1		2	
1A part #	1G part #				mm	in	mm	in	mm	in	mm	in	mm	in
<b>1A4FR4</b>	<b>1G4FR4</b>	-04	-04	9/16" - 18	46.3	1.82	26.1	1.03	4.2	0.17	17	0.67	14	0.55
<b>1A6FR4</b>	<b>1G6FR4</b>	-06	-04	11/16" - 16	49.9	1.96	28.4	1.12	4.2	0.17	22	0.87	14	0.55
<b>1A6FR5</b>	<b>1G6FR5</b>	-06	-05	11/16" - 16	50.3	1.98	28.7	1.13	5.3	0.21	22	0.87	17	0.67
<b>1A6FR6</b>	<b>1G6FR6</b>	-06	-06	11/16" - 16	52.7	2.07	31.4	1.24	6.7	0.26	22	0.87	17	0.67
<b>1A8FR6</b>	<b>1G8FR6</b>	-08	-06	13/16" - 16	54.4	2.14	33.6	1.32	6.7	0.26	24	0.94	17	0.67
<b>1A8FR8</b>	<b>1G8FR8</b>	-08	-08	13/16" - 16	64.7	2.55	38.1	1.50	9.1	0.36	24	0.94	22	0.87
<b>1A10FR8</b>	<b>1G10FR8</b>	-10	-08	1" - 14	63.8	2.51	37.3	1.47	9.6	0.38	30	1.18	24	0.94
<b>1A10FR10</b>	<b>1G10FR10</b>	-10	-10	1" - 14	66.3	2.61	40.8	1.61	11.5	0.45	30	1.18	27	1.06
<b>1A12FR12</b>	<b>1G12FR12</b>	-12	-12	1 3/16" - 12	71.2	2.80	43.7	1.72	15.5	0.61	36	1.42	30	1.18
<b>1A16FR16</b>	<b>1G16FR16</b>	-16	-16	1 7/16" - 12	81.4	3.21	49.1	1.93	20.7	0.82	41	1.61	36	1.42
<b>1A20FR20*</b>	<b>1G20FR20</b>	-20	-20	1 11/16" - 12	98.8	3.89	59.3	2.33	26.0	1.02	50	1.97	46	1.81
<b>1A24FR24</b>	<b>1G24FR24</b>	-24	-24	2" - 12	104.4	4.11	60.4	2.38	32.0	1.26	60	2.36	50	1.97

\* one wire

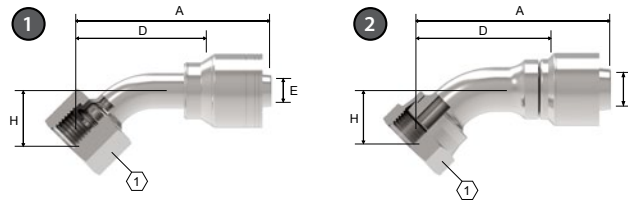

# FRA

ORS Female Swivel - 45° Elbow (FRA)

PART		HOSE SIZE INFO			DIMENSIONS									
1	2	Terminal end	Hose size	Thd.	A		D		EØ		H		1	
1A part #	1G part #				mm	in	mm	in	mm	in	mm	in	mm	in
<b>1A4FRA4</b>	<b>1G4FRA4</b>	-04	-04	9/16" - 18	50.6	1.99	30.4	1.20	4.2	0.17	10.4	0.41	17	0.67
<b>1A6FRA5</b>	<b>1G6FRA5</b>	-05	-05	11/16" - 16	57.0	2.24	35.4	1.39	5.3	0.21	10.9	0.43	22	0.87
<b>1A6FRA6</b>	<b>1G6FRA6</b>	-06	-06	11/16" - 16	59.9	2.36	36.3	1.43	6.2	0.24	10.9	0.43	22	0.87
<b>1A8FRA6</b>	<b>1G8FRA6</b>	-06	-06	13/16" - 16	65.6	2.58	44.3	1.74	6.7	0.26	15.0	0.59	24	0.94
<b>1A8FRA8</b>	<b>1G8FRA8</b>	-08	-08	13/16" - 16	74.5	2.93	45.5	1.79	8.5	0.33	15.0	0.59	24	0.94
<b>1A10FRA10</b>	<b>1G10FRA10</b>	-10	-10	1" - 14	80.9	3.18	51.3	2.02	11.1	0.44	16.5	0.65	30	1.18
<b>1A12FRA12</b>	<b>1G12FRA12</b>	-12	-12	1 3/16" - 12	92.1	3.63	60.4	2.38	14.8	0.58	21.1	0.83	36	1.42
<b>1A16FRA16</b>	<b>1G16FRA16</b>	-16	-16	1 7/16" - 12	111.6	4.39	73.1	2.88	20.6	0.81	23.9	0.94	41	1.61
<b>1A20FRA20*</b>	<b>1G20FRA20</b>	-20	-20	1 11/16" - 12	125.1	4.93	85.6	3.37	26.0	1.02	25.4	1.00	50	1.97
<b>1A24FRA24</b>	<b>1G24FRA24</b>	-24	-24	2" - 12	123.3	4.85	79.6	3.13	32.0	1.26	27.3	1.07	60	2.36

\* one wire

## 1A and 1G TTC braided series

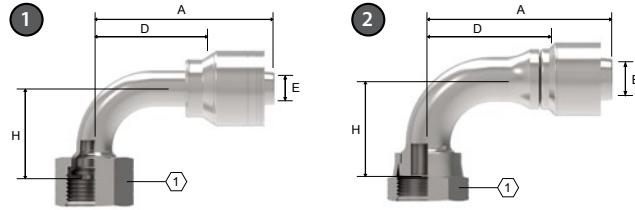

# FRB

ORS Female Swivel - 90° Elbow - Short Drop (FRB)

PART		HOSE SIZE INFO			DIMENSIONS									
①	②	Terminal end	Hose size	Thd.	A		D		EØ		H		①	
1A part #	1G part #				mm	in	mm	in	mm	in	mm	in	mm	in
<b>1A4FRB4</b>	<b>1G4FRB4</b>	-04	-04	9/16" - 18	44.7	1.76	23.3	0.92	4.2	0.17	20.8	0.82	17	0.67
<b>1A6FRB4</b>	<b>1G6FRB4</b>	-06	-04	11/16" - 16	53.1	2.09	32.9	1.30	4.2	0.17	22.9	0.90	22	0.87
<b>1A6FRB5</b>	<b>1G6FRB5</b>	-06	-05	11/16" - 16	54.8	2.16	33.2	1.31	5.3	0.21	22.9	0.90	22	0.87
<b>1A6FRB6</b>	<b>1G6FRB6</b>	-06	-06	11/16" - 16	57.6	2.27	34.1	1.34	6.2	0.24	22.9	0.90	22	0.87
<b>1A8FRB6</b>	<b>1G8FRB6</b>	-08	-06	13/16" - 16	62.5	2.46	41.2	1.62	6.7	0.26	29.2	1.15	24	0.94
<b>1A8FRB8</b>	<b>1G8FRB8</b>	-08	-08	13/16" - 16	71.4	2.81	42.4	1.67	8.5	0.33	29.2	1.15	24	0.94
<b>1A10FRB10</b>	<b>1G10FRB10</b>	-10	-10	1" - 14	78.3	3.08	48.6	1.91	11.1	0.44	32.3	1.27	30	1.18
<b>1A12FRB12</b>	<b>1G12FRB12</b>	-12	-12	1 3/16" - 12	90.1	3.55	58.4	2.30	14.8	0.58	47.8	1.88	36	1.42
<b>1A16FRB16</b>	<b>1G16FRB16</b>	-16	-16	1 7/16" - 12	111.3	4.38	72.9	2.87	20.6	0.81	56.1	2.21	41	1.61
<b>1A20FRB20*</b>	<b>1G20FRB20</b>	-20	-20	1 11/16" - 12	130.1	5.12	90.6	3.57	26.0	1.02	63.8	2.51	50	1.97
<b>1A24FRB24</b>	<b>1G24FRB24</b>	-24	-24	2" - 12	115.1	4.53	71.4	2.81	32.0	1.26	68.6	2.70	60	2.36

\* one wire

# FRC

ORS Female Swivel - 90° Elbow - Long Drop (FRC)

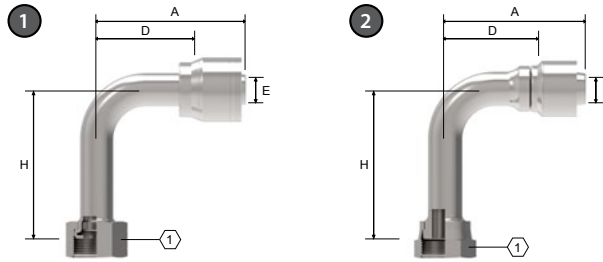

PART		HOSE SIZE INFO			DIMENSIONS									
1 1A part #	1G part #	Terminal end	Hose size	Thd.	A		D		EØ		H		1	
					mm	in	mm	in	mm	in	mm	in	mm	in
<b>1A4FRC4</b>	<b>1G4FRC4</b>	-04	-04	9/16" - 18	49.5	1.95	29.3	1.15	4.2	0.17	46.0	1.80	17	0.67
<b>1A6FRC6</b>	<b>1G6FRC6</b>	-06	-06	11/16" - 16	57.6	2.27	34.1	1.34	6.2	0.24	54.1	2.13	22	0.87
<b>1A8FRC8</b>	<b>1G8FRC8</b>	-08	-08	13/16" - 16	71.4	2.81	42.4	1.67	8.5	0.33	63.8	2.51	24	0.94
<b>1A10FRC10</b>	<b>1G10FRC10</b>	-10	-10	1" - 14	78.3	3.08	48.6	1.91	11.0	0.44	70.1	2.76	30	1.18
<b>1A12FRC12</b>	<b>1G12FRC12</b>	-12	-12	1 3/16" - 12	90.1	3.55	58.4	2.30	14.8	0.58	96.0	3.78	36	1.42
<b>1A16FRC16</b>	<b>1G16FRC16</b>	-16	-16	1 7/16" - 12	111.3	4.38	72.9	2.87	20.6	0.81	114.3	4.50	41	1.61
<b>1A20FRC20*</b>	<b>1G20FRC20</b>	-20	-20	1 11/18" - 12	132.5	5.22	93.0	3.66	26.0	1.01	129.5	5.09	50	1.97

\* one wire

## 1A and 1G TTC braided series

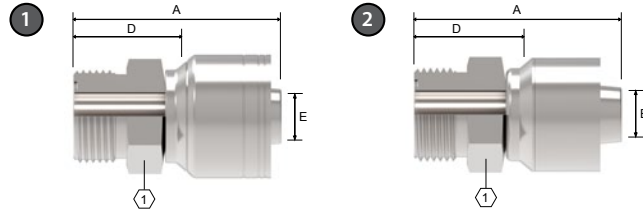

# MR

ORS Male (MR)

PART		HOSE SIZE INFO			DIMENSIONS							
①	②	Terminal end	Hose size	Thd.	A		D		E∅		①	
1A part #	1G part #				mm	in	mm	in	mm	in	mm	in
<b>1A6MR4</b>	<b>1G6MR4</b>	-06	-04	11/16" - 16UN	44.8	1.77	21.4	0.84	4.2	0.17	19	0.75
<b>1A6MR5</b>	<b>1G6MR5</b>	-06	-05	11/16" - 16UN	45.7	1.80	21.7	0.85	5.3	0.21	19	0.75
<b>1A6MR6</b>	<b>1G6MR6</b>	-06	-06	11/16" - 16UN	52.1	2.10	29.3	1.16	6.7	0.26	19	0.75
<b>1A8MR6</b>	<b>1G8MR6</b>	-08	-06	13/16" - 16UN	51.6	2.03	29.0	1.14	6.7	0.26	22	0.87
<b>1A10MR8</b>	<b>1G10MR8</b>	-10	-08	1" - 14UN	55.2	2.17	29.7	1.17	9.6	0.38	27	1.06
<b>1A12MR10</b>	<b>1G12MR10</b>	-12	-10	1 3/16" - 12UN	60.8	2.39	31.4	1.24	12.8	0.50	32	1.26
<b>1A12MR12</b>	<b>1G12MR12</b>	-12	-12	1 3/16" - 12UN	70.4	2.77	39.0	1.53	15.5	0.61	32	1.26
<b>1A16MR12</b>	<b>1G16MR12</b>	-16	-12	1 7/16" - 12UN	61.2	2.41	34.0	1.34	15.5	0.61	41	1.61
<b>1A16MR16</b>	<b>1G16MR16</b>	-16	-16	1 7/16" - 12UN	80.5	3.17	42.9	1.69	20.6	0.81	38	1.50
<b>1A20MR16</b>	<b>1G20MR16</b>	-20	-16	1 11/16" - 12UN	69.0	2.72	34.6	1.36	20.7	0.81	46	1.81

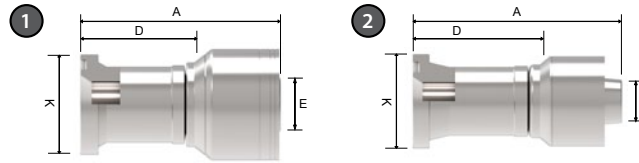

# FL

SAE CODE 61 Flange (FL)

PART		HOSE SIZE INFO		DIMENSIONS							
1	2	Flange size	Hose size	A		D		KØ		EØ	
1A part #	1G part #			mm	in	mm	in	mm	in	mm	in
<b>1A8FL8</b>	<b>1G8FL8</b>	1/2"	-08	77.8	3.06	52.3	2.06	30.2	1.19	9.6	0.38
<b>1A12FL10</b>	<b>1G12FL10</b>	3/4"	-10	79.4	3.13	53.3	2.10	38.1	1.50	12.8	0.50
<b>1A12FL12</b>	<b>1G12FL12</b>	3/4"	-12	80.9	3.18	53.8	2.12	38.1	1.50	15.5	0.61
<b>1A16FL12</b>	<b>1G16FL12</b>	1"	-12	80.9	3.18	53.8	2.12	44.4	1.75	15.5	0.61
<b>1A12FL16</b>	<b>1G12FL16</b>	3/4"	-16	88.2	3.47	54.4	2.14	38.1	1.50	13.9	0.55
<b>1A16FL16</b>	<b>1G16FL16</b>	1"	-16	88.2	3.47	54.4	2.14	44.4	1.75	20.7	0.81
<b>1A20FL16</b>	<b>1G20FL16</b>	1 1/4"	-16	95.8	3.77	62.0	2.44	50.8	2.00	20.7	0.81
<b>1A20FL20</b>	<b>1G20FL20</b>	1 1/4"	-20	103.3	4.07	63.8	2.51	50.8	2.00	26.6	1.05
<b>1A24FL20</b>	<b>1G24FL20</b>	1 1/2"	-20	104.0	4.09	64.5	2.54	60.3	2.37	26.6	1.05
<b>1A20FL24</b>	<b>1G20FL24</b>	1 1/4"	-24	108.5	4.27	64.8	2.55	50.8	2.00	26.6	1.05
<b>1A24FL24</b>	<b>1G24FL24</b>	1 1/2"	-24	109.2	4.30	65.5	2.58	60.4	2.38	32.0	1.26
<b>1A32FL24</b>	<b>1G32FL24</b>	2"	-24	109.2	4.30	65.5	2.58	71.4	2.81	32.0	1.26
<b>1A32FL32</b>	<b>1G32FL32</b>	2"	-32	111.0	4.37	64.8	2.55	71.4	2.81	44.4	1.75

## 1A and 1G TTC braided series

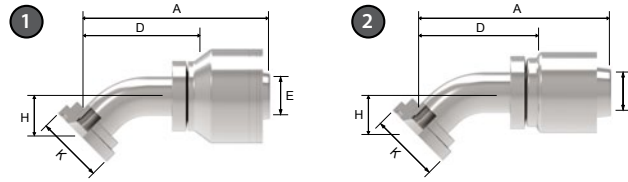

# FLA

SAE CODE 61 Flange - 45° Elbow (FLA)

PART		HOSE SIZE INFO		DIMENSIONS									
1	2	Flange size	Hose size	A		D		KØ		EØ		H	
1A part #	1G part #			mm	in	mm	in	mm	in	mm	in	mm	in
<b>1A8FLA8</b>	<b>1G8FLA8</b>	1/2"	-08	75.8	2.98	50.3	1.98	30.2	1.19	9.1	0.36	19.8	0.78
<b>1A12FLA8</b>	<b>1G12FLA8</b>	3/4"	-08	88.2	3.48	62.8	2.47	38.1	1.50	9.4	0.37	25.4	1.00
<b>1A12FLA12</b>	<b>1G12FLA12</b>	3/4"	-12	90.0	3.54	62.9	2.48	31.8	1.25	14.8	0.58	25.4	1.00
<b>1A16FLA12</b>	<b>1G16FLA12</b>	1"	-12	102.6	4.04	75.5	2.97	44.4	1.75	14.8	0.58	26.9	1.06
<b>1A12FLA16</b>	<b>1G12FLA16</b>	3/4"	-16	99.2	3.91	65.4	2.57	38.1	1.50	14.8	0.58	25.6	1.00
<b>1A16FLA16</b>	<b>1G16FLA16</b>	1"	-16	109.9	4.33	76.1	2.99	44.4	1.75	19.3	0.76	26.9	1.06
<b>1A20FLA16</b>	<b>1G20FLA16</b>	1 1/4"	-16	121.5	4.78	87.7	3.45	50.8	2.00	19.3	0.76	29.2	1.15
<b>1A16FLA20</b>	<b>1G16FLA20</b>	1"	-20	117.3	4.62	77.8	3.06	44.4	1.75	19.3	0.76	26.9	1.06
<b>1A20FLA20</b>	<b>1G20FLA20</b>	1 1/4"	-20	129.7	5.11	90.2	3.55	50.8	2.00	26.6	1.05	29.2	1.15
<b>1A24FLA20</b>	<b>1G24FLA20</b>	1 1/2"	-20	146.2	5.76	106.7	4.20	60.3	2.37	25.7	1.01	35.8	1.41
<b>1A24FLA24</b>	<b>1G24FLA24</b>	1 1/2"	-24	151.6	5.97	107.9	4.25	60.3	2.37	32.0	1.26	35.8	1.41
<b>1A32FLA24</b>	<b>1G32FLA24</b>	2"	-24	151.6	5.97	107.9	4.25	71.4	2.81	32.0	1.26	35.8	1.41
<b>1A32FLA32</b>	<b>1G32FLA32</b>	2"	-32	184.3	7.26	138.1	5.44	71.4	2.81	44.4	1.75	50.8	2.00

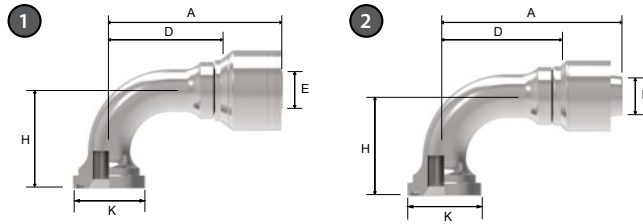

# FLB

SAE CODE 61 Flange - 90° Elbow (FLB)

PART		HOSE SIZE INFO		DIMENSIONS									
1	2	Flange size	Hose size	A		D		KØ		EØ		H	
1A part #	1G part #			mm	in	mm	in	mm	in	mm	in	mm	in
<b>1A8FLB8</b>	<b>1G8FLB8</b>	1/2"	-08	67.8	2.67	42.3	1.67	30.2	1.19	9.1	0.36	41.4	1.63
<b>1A12FLB12</b>	<b>1G12FLB12</b>	3/4"	-12	85.6	3.37	58.5	2.30	38.1	1.50	13.9	0.55	54.1	2.13
<b>1A16FLB12</b>	<b>1G16FLB12</b>	1"	-12	99.3	3.91	72.2	2.84	44.4	1.75	15.5	0.61	60.3	2.37
<b>1A12FLB16</b>	<b>1G12FLB16</b>	3/4"	-16	92.9	3.66	59.1	2.33	38.1	1.50	13.9	0.55	54.1	2.13
<b>1A16FLB16</b>	<b>1G16FLB16</b>	1"	-16	106.5	4.19	72.7	2.86	44.4	1.75	19.9	0.78	60.3	2.37
<b>1A20FLB16</b>	<b>1G20FLB16</b>	1 1/4"	-16	122.7	4.83	88.9	3.50	50.8	2.00	19.3	0.76	66.6	2.62
<b>1A16FLB20</b>	<b>1G16FLB20</b>	1"	-20	113.9	4.48	74.4	2.93	44.4	1.75	19.9	0.78	60.3	2.37
<b>1A16FLB20</b>	—	1 1/4"	-20	113.9	4.48	74.4	2.93	44.4	1.75	19.9	0.78	60.3	2.37
<b>1A20FLB20</b>	<b>1G20FLB20</b>	1 1/4"	-20	130.1	5.12	90.6	3.57	50.8	2.00	23.5	0.93	66.6	2.62
<b>1A24FLB20</b>	<b>1G24FLB20</b>	1 1/2"	-20	148.9	5.86	109.4	4.31	60.3	2.37	25.7	1.01	79.3	3.12



## 1A and 1G TTC braided series

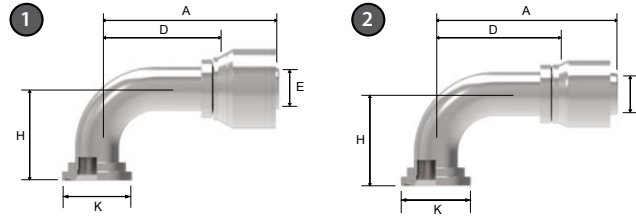

# FLB

SAE CODE 61 Flange - 90° Elbow (FLB)

PART		HOSE SIZE INFO		DIMENSIONS									
1	2	Flange size	Hose size	A		D		KØ		EØ		H	
1A part #	1G part #			mm	in	mm	in	mm	in	mm	in	mm	in
<b>1A24FLB20</b>	—	1 1/2"	-20	148.9	5.86	109.4	4.31	60.3	2.37	26.7	1.05	79.3	3.12
<b>1A20FLB24</b>	<b>1G20FLB24</b>	1 1/4"	-24	135.4	5.33	91.7	3.61	50.8	2.00	25.7	1.01	66.6	2.62
<b>1A24FLB24</b>	<b>1G24FLB24</b>	1 1/2"	-24	154.3	6.07	110.6	4.35	60.3	2.37	32.0	1.26	79.3	3.12
<b>1A32FLB24</b>	<b>1G32FLB24</b>	2"	-24	182.2	7.17	138.5	5.45	71.4	2.81	32.0	1.26	114.3	4.50
<b>1A32FLB32</b>	<b>1G32FLB32</b>	2"	-32	183.7	7.23	137.5	5.41	71.4	2.81	44.4	1.75	114.3	4.50

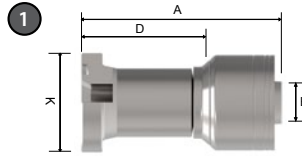

# FH

SAE CODE 62 Flange (FH)

PART	HOSE SIZE INFO		DIMENSIONS								
	1A part #	Flange size	Hose size	A		D		KØ		EØ	
			mm	in	mm	in	mm	in	mm	in	
<b>1A8FH8</b>		1/2"	-08	77.6	3.06	52.3	2.06	31.8	1.25	9.6	0.38
<b>1A8FH16</b>		1/2"	-16	82.2	3.24	47.8	1.88	31.8	1.25	20.7	0.81
<b>1A12FH12</b>		3/4"	-12	85.0	3.35	54.0	2.13	41.3	1.63	16.0	0.63
<b>1A12FH16</b>		3/4"	-16	89.0	3.50	54.6	2.15	41.3	1.63	20.7	0.81
<b>1A16FH16</b>		1"	-16	88.8	3.49	54.4	2.14	47.6	1.87	20.7	0.81
<b>1A16FH20*</b>		1"	-20	111.0	4.37	67.0	2.64	47.6	1.87	26.6	1.05
<b>1A20FH20*</b>		1 1/4"	-20	107.8	4.24	63.8	2.51	54.0	2.13	26.6	1.05
<b>1A20FH24</b>		1 1/4"	-24	119.0	4.69	73.0	2.87	54.0	2.13	32.0	1.26
<b>1A24FH20*</b>		1 1/2"	-20	116.0	4.57	72.0	2.83	63.5	2.50	26.6	1.05
<b>1A24FH24</b>		1 1/2"	-24	108.9	4.29	65.5	2.58	63.5	2.50	32.0	1.26

\* one wire

## 1A and 1G TTC braided series

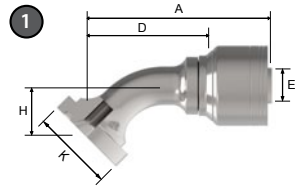

# FHA

SAE CODE 62 Flange - 45° Elbow (FHA)

PART ① 1A part #	HOSE SIZE INFO		DIMENSIONS									
	Flange size	Hose size	A		D		KØ		EØ		H	
			mm	in	mm	in	mm	in	mm	in	mm	in
<b>1A8FHA16</b>	1/2"	-16	91.0	3.58	57.0	2.24	31.8	1.25	21.0	0.83	20.0	0.79
<b>1A12FHA12</b>	3/4"	-12	96.0	3.78	65.0	2.56	41.3	1.63	16.0	0.63	26.0	1.02
<b>1A12FHA16</b>	3/4"	-16	99.9	3.93	65.5	2.58	41.2	1.62	20.7	0.81	25.7	1.01
<b>1A16FHA16</b>	1"	-16	103.0	4.06	69.0	2.72	47.6	1.87	21.0	0.83	27.0	1.06
<b>1A20FHA20*</b>	1 1/4"	-20	113.0	4.45	69.0	2.72	54.0	2.13	26.6	1.05	29.0	1.14

\* one wire

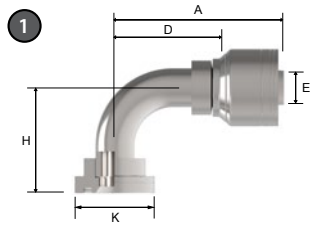

# FHB

SAE CODE 62 Flange - 90° Elbow (FHB)

PART 1A part #	HOSE SIZE INFO		DIMENSIONS									
	Flange size	Hose size	A		D		KØ		EØ		H	
			mm	in	mm	in	mm	in	mm	in	mm	in
<b>1A16FHB16.068</b>	1"	-16	123.5	4.86	89.1	3.51	47.6	1.87	20.7	0.81	68.0	2.68
<b>1A16FHB16.100</b>	1"	-16	101.5	4.00	67.1	2.64	47.6	1.87	20.7	0.81	100.0	3.94
<b>1A16FHB20*</b>	1"	-20	107.0	4.21	63.0	2.48	47.6	1.87	26.6	1.05	61.0	2.40
—	1"	-20	112.7	4.44	68.7	2.70	47.6	1.87	26.6	1.05	81.0	3.19

\* one wire

## Hose to fitting chart

Socket type by hose

Global 1A fittings				Global 1G fittings	
Hose part #	Socket:	Hose part #	Socket:	Hose part #	Socket:
GH681	1A	FC310	1A	FC619	1G
GH681B	1A	SH222	1A	2661	1G
FC510	1A	EC110	1A	GH585	1G
GH781	1A	EC210	1A	WH004	1G
EC881	1A	EC210	1A		
GH195	1A	EC215	1A		
GH120	1A	EC118	1A		
FC619	1A	WH004	1A		
2661	1A				

Aeroquip by Danfoss

## Braided fittings

Reusable 1R & 2R Series

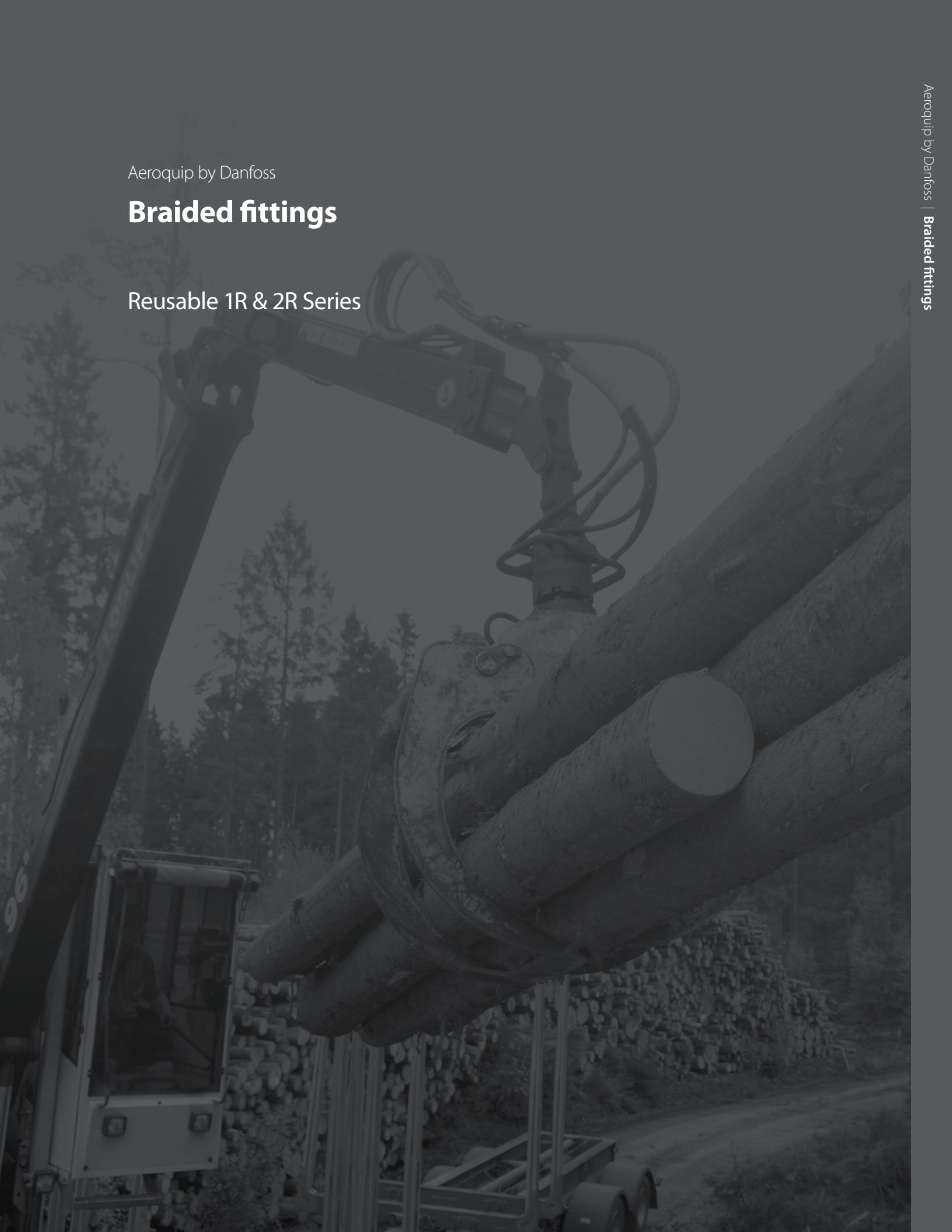

## Reusable 1R and 2R series

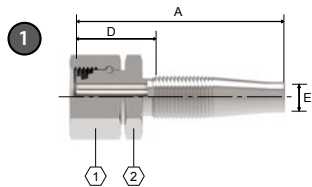

# GA10933

DIN 24° DKO Light Female

PART	HOSE SIZE INFO			DIMENSIONS									
	Terminal end	Hose size	Thd.	A		D		EØ		1		2	
1 Nipple / nipple part assembly #				mm	in	mm	in	mm	in	mm	in	mm	in
<b>GA10933-4</b>	8L	-04	M14 x 1.5	64.5	2.54	36.3	1.43	4.0	0.16	17	0.67	17	0.67
<b>GA17568-6</b>	10L	-06	M16 x 1.5	72.0	2.83	40.0	1.57	8.0	0.31	19	0.75	19	0.75
<b>GA10933-6</b>	12L	-06	M18 x 1.5	75.0	2.95	43.0	1.69	8.0	0.31	22	0.87	22	0.87
<b>GA10933-8</b>	15L	-08	M22 x 1.5	77.0	3.03	38.3	1.51	10.0	0.39	27	1.06	27	1.06
<b>GA10933-12</b>	22L	-12	M30 x 2.0	92.8	3.65	47.7	1.88	15.5	0.61	36	1.42	36	1.42
<b>GA10933-16</b>	28L	-16	M36 x 2.0	105.5	4.15	55.6	2.19	20.5	0.81	41	1.61	41	1.61

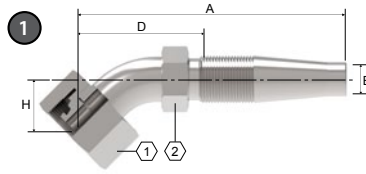

# GA17537

DIN 24° DKO Light Female - 45° Elbow

PART	HOSE SIZE INFO			DIMENSIONS											
	Terminal end	Hose size	Thd.	A		D		EØ		H		1		2	
1 Nipple / nipple part assembly #				mm	in	mm	in	mm	in	mm	in	mm	in	mm	in
<b>GA17537-4</b>	8L	-04	M14 x 1.5	72.6	2.86	44.6	1.76	4.3	0.17	14.1	0.55	17	0.67	14	0.55
<b>GA17571-6</b>	10L	-06	M16 x 1.5	83.9	3.30	52.1	2.05	8.0	0.31	16.5	0.65	19	0.75	17	0.67
<b>GA17537-6</b>	12L	-06	M18 x 1.5	83.7	3.30	52.1	2.05	8.0	0.31	17.2	0.68	22	0.87	17	0.67
<b>GA17537-8</b>	15L	-08	M22 x 1.5	89.9	3.54	51.3	2.02	10.0	0.39	17.8	0.70	27	1.06	19	0.748
<b>GA17537-12</b>	22L	-12	M30 x 2.0	107.7	4.24	62.7	2.47	15.5	0.61	20.8	0.82	36	1.42	27	1.06
<b>GA17537-16</b>	28L	-16	M36 x 2.0	130.1	5.12	80.1	3.15	20.5	0.81	25.0	0.98	41	1.61	32	1.26



## Reusable 1R and 2R series

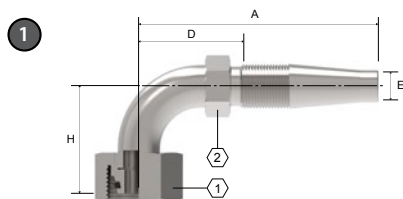

# GA17544

DIN 24° DKO Light Female - 90° Elbow

PART	HOSE SIZE INFO			DIMENSIONS												
	Nipple / nipple part assembly #	Terminal end	Hose size	Thd.	A		D		EØ		H		1		2	
					mm	in	mm	in	mm	in	mm	in	mm	in	mm	in
<b>GA17544-4</b>		8L	-04	M14 x 1.5	65.8	2.59	37.6	1.48	4.4	0.17	27.3	1.07	17	0.67	14	0.55
<b>GA15063-6</b>		10L	-06	M16 x 1.5	77.5	3.05	41.0	1.61	7.9	0.31	33.8	1.33	19	0.75	17	0.67
<b>GA17544-6</b>		12L	-06	M18 x 1.5	77.5	3.05	45.5	1.79	8.0	0.31	34.5	1.36	22	0.87	17	0.67
<b>GA17544-8</b>		15L	-08	M22 x 1.5	85.0	3.35	46.3	1.82	10.0	0.39	38.0	1.51	27	1.06	19	0.75
<b>GA17544-12</b>		22L	-12	M30 x 2.0	104.5	4.11	59.4	2.34	15.5	0.61	47.0	1.86	36	1.42	27	1.06
<b>GA17544-16</b>		28L	-16	M36 x 2.0	128.5	5.06	78.6	3.09	20.5	0.81	58.5	2.31	41	1.61	32	1.26

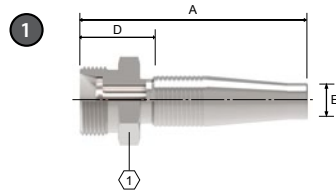

# 11.013

DIN 24° DKO Light (DKO-L) Male

PART	HOSE SIZE INFO			DIMENSIONS							
	Terminal end	Hose size	Thd.	A		D		EØ		①	
① Nipple / nipple part assembly #				mm	in	mm	in	mm	in	mm	in
<b>11.013-6-4</b>	6L	-04	M12 x 1.5	60.0	2.36	31.8	1.25	4.1	0.16	14	0.55
<b>11.013-8-4</b>	8L	-04	M14 x 1.5	60.0	2.36	31.8	1.25	4.4	0.17	17	0.67
<b>11.013-10-6</b>	10L	-06	M16 x 1.5	67.0	2.64	35.0	1.38	7.9	0.31	17	0.67
<b>11.013-12-6</b>	12L	-06	M18 x 1.5	67.0	2.64	35.0	1.38	8.1	0.32	22	0.87
<b>11.013-15-8</b>	15L	-08	M22 x 1.5	71.5	2.81	32.8	1.29	9.9	0.39	24	0.94
<b>11.013-22-12</b>	22L	-12	M30 x 2.0	87.0	3.43	41.9	1.65	15.5	0.61	32	1.26
<b>11.013-28-16</b>	28L	-16	M36 x 2.0	98.0	3.86	48.1	1.89	20.7	0.81	41	1.61

## Reusable 1R and 2R series

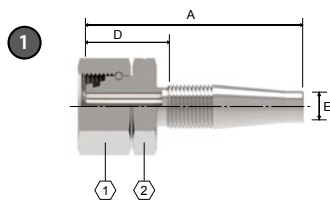

# 11.721

DIN 24° DKO Heavy Female

PART	HOSE SIZE INFO			DIMENSIONS									
	Terminal end	Hose size	Thd.	A		D		EØ		1		2	
1 Nipple / nipple part assembly #				mm	in	mm	in	mm	in	mm	in	mm	in
11.721-10-4	10S	-04	M18 x 1.5	69.4	2.73	41.2	1.62	4.1	0.16	22	0.87	22	0.87
11.721-12-6	12S	-06	M20 x 1.5	71.5	2.81	39.5	1.56	8.1	0.32	24	0.94	24	0.94
11.721-14-6	14S	-06	M22 x 1.5	71.5	2.81	39.5	1.56	7.9	0.31	27	1.06	27	1.06
11.721-16-8	16S	-08	M24 x 1.5	78.0	3.07	39.3	1.55	9.9	0.39	30	1.18	30	1.18
11.721-25-12	25S	-12	M36 x 2.0	94.5	3.72	49.4	1.94	15.5	0.61	41	1.61	41	1.61
11.721-30-16	30S	-16	M42 x 2.0	106.0	4.17	56.1	2.21	20.7	0.81	50	1.97	50	1.97

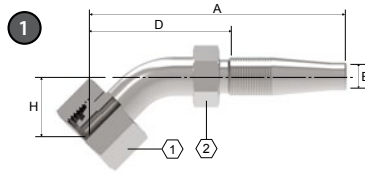

# 11.839

DIN 24° DKO Heavy Female - 45° Elbow

PART	HOSE SIZE INFO			DIMENSIONS											
	Terminal end	Hose size	Thd.	A		D		EØ		H		1		2	
1 Nipple / nipple part assembly #				mm	in	mm	in	mm	in	mm	in	mm	in	mm	in
<b>11.839-8-4</b>	8S	-04	M16 x 1.5	73.6	2.89	45.3	1.78	4.4	0.16	15.1	0.59	19	0.75	14	0.55
<b>11.839-10-4</b>	10S	-04	M18 x 1.5	77.2	3.04	49.0	1.93	4.3	0.16	16.8	0.66	22	0.87	14	0.55
<b>11.839-12-6</b>	12S	-06	M20 x 1.5	83.9	3.30	51.9	2.04	8.0	0.31	17.4	0.69	24	0.94	17	0.67
<b>11.839-16-8</b>	16S	-08	M24 x 1.5	106.7	4.20	67.9	2.67	10.0	0.39	25.4	1.00	30	1.18	22	0.87
<b>11.839-25-12</b>	25S	-12	M36 x 2.0	141.0	5.55	95.8	3.77	15.6	0.61	35.9	1.41	46	1.81	32	1.26
<b>11.839-30-16</b>	30S	-16	M42 x 2.0	156.0	6.14	106.1	4.18	20.7	0.81	36.9	1.45	50	1.97	36	1.42

## Reusable 1R and 2R series

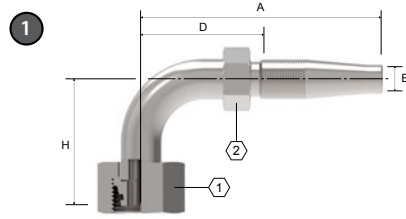

# 11.840

DIN 24° DKO Heavy Female - 90° Elbow

PART	HOSE SIZE INFO			DIMENSIONS												
	Nipple / nipple part assembly #	Terminal end	Hose size	Thd.	A		D		EØ		H		1		2	
					mm	in	mm	in	mm	in	mm	in	mm	in	mm	in
<b>11.840-10-4</b>		10S	-04	M18 x 1.5	67.9	2.68	39.8	1.57	4.4	0.16	34.8	1.37	22	0.87	14	0.55
<b>11.840-12-6</b>		12S	-06	M20 x 1.5	77.5	3.05	45.5	1.79	8.0	0.31	34.8	1.36	24	0.94	17	0.67
<b>11.840-16-8</b>		16S	-08	M24 x 1.5	96.0	3.78	57.2	2.25	8.9	0.35	50.2	1.98	30	1.18	22	0.87
<b>11.840-25-12</b>		25S	-12	M36 x 2.0	128.5	5.06	83.3	3.28	15.5	0.61	74.5	2.92	46	1.81	32	1.26
<b>11.840-30-16</b>		30S	-16	M42 x 2.0	145.5	5.73	98.9	3.89	20.7	0.81	78.5	3.09	50	1.97	36	1.42

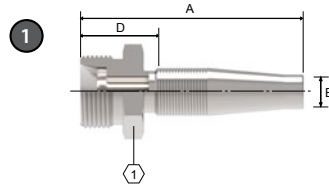

# 11.005

DIN 24° DKO Heavy Male

PART	HOSE SIZE INFO			DIMENSIONS							
	Terminal end	Hose size	Thd.	A		D		EØ		1	
1 Nipple / nipple part assembly #				mm	in	mm	in	mm	in	mm	in
<b>11.005-8-4</b>	8S	-04	M16 x 1.5	62.0	2.44	33.8	1.33	4.1	0.16	17	0.67
<b>11.005-10-4</b>	10S	-04	M18 x 1.5	62.0	2.44	33.8	1.33	4.1	0.16	19	0.75
<b>11.005-12-6</b>	12S	-06	M20 x 1.5	68.0	2.68	36.0	1.42	7.2	0.28	22	0.87
<b>11.005-14-6</b>	14S	-06	M22 x 1.5	70.0	2.76	38.0	1.50	7.2	0.28	24	0.94
<b>11.005-16-8</b>	16S	-08	M24 x 1.5	73.5	2.89	34.7	1.37	10.1	0.40	27	1.06
<b>11.005-25-12</b>	25S	-12	M36 x 2.0	91.0	3.58	45.8	1.80	15.6	0.61	41	1.61
<b>11.005-30-16</b>	30S	-16	M42 x 2.0	104.0	4.09	54.2	2.13	20.6	0.81	46	1.81

## Reusable 1R and 2R series

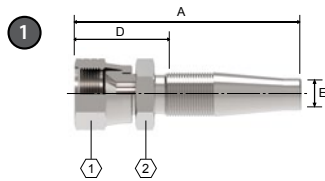

# G4103

JIC 37° Female Swivel

PART	HOSE SIZE INFO			DIMENSIONS									
	Terminal end	Hose size	Thd.	A		D		EØ		1		2	
1 Nipple / nipple part assembly #				mm	in	mm	in	mm	in	mm	in	mm	in
<b>G4103-4-4-4</b>	-04	-04	7/16" - 20	57.5	2.26	29.3	1.15	4.0	0.16	14	0.55	14	0.55
<b>G4103-4-5-4</b>	-05	-04	1/2" - 20	58.0	2.28	29.7	1.17	4.0	0.16	17	0.67	17	0.67
<b>G4103-4-6-4DR</b>	-06	-04	9/16" - 18	59.4	2.34	31.2	1.23	4.0	0.16	17	0.67	17	0.67
<b>G4103-4-6-6DR</b>	-06	-06	9/16" - 18	65.0	2.56	32.4	1.28	7.2	0.28	17	0.67	17	0.67
<b>G4103-4-8-8</b>	-08	-08	3/4" - 16	70.0	2.76	31.2	1.23	8.9	0.35	22	0.87	22	0.87
<b>G4103-4-12-12</b>	-12	-12	1 1/16" - 12	84.0	3.31	38.8	1.53	14.2	0.56	32	1.26	32	1.26
<b>G4103-4-16-12</b>	-16	-12	1 5/16" - 12	86.5	3.41	41.4	1.63	15.5	0.61	41	1.61	41	1.61
<b>G4103-4-16-16</b>	-16	-16	1 5/16" - 12	97.5	3.84	48.4	1.91	20.5	0.81	41	1.61	41	1.61

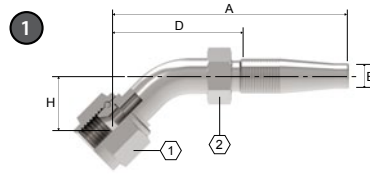

# G185287

JIC 37° Female Swivel - 45° Elbow (FJA)

PART	HOSE SIZE INFO			DIMENSIONS											
	Ter- minal end	Hose size	Thd.	A		D		EØ		H		1		2	
1 Nipple / nipple part assembly #				mm	in	mm	in	mm	in	mm	in	mm	in	mm	in
<b>G185287-4</b>	-04	-04	7/16" - 20	77.3	3.04	49.0	1.93	4.4	0.17	12.0	0.47	14	0.55	14	0.55
<b>G185287-6-4</b>	-06	-04	9/16" - 18	75.2	2.96	45.0	1.77	4.4	0.17	14.8	0.58	17	0.67	14	0.55
<b>G185287-8-6</b>	-08	-06	3/4" - 16	87.6	3.45	55.6	2.19	5.5	0.22	18.6	0.73	22	0.87	17	0.67
<b>G185287-10-8</b>	-10	-08	7/8" - 14	106.5	4.19	67.2	2.65	10.0	0.39	24.5	0.97	27	1.06	22	0.87
<b>G185287-12</b>	-12	-12	1 1/16" - 12	116.6	4.59	71.4	2.81	12.7	0.50	24.5	0.97	32	1.26	27	1.06
<b>G185287-16</b>	-16	-16	1 5/16" - 12	154.8	6.09	105.0	4.13	19.0	0.75	37.7	1.48	41	1.61	32	1.26



## Reusable 1R and 2R series

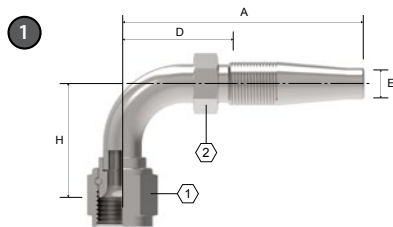

# G185264

JIC 37° Female Swivel - 90° Elbow

PART	HOSE SIZE INFO			DIMENSIONS											
	Ter- minal end	Hose size	Thd.	A		D		EØ		H		1		2	
1 Nipple / nipple part assembly #				mm	in	mm	in	mm	in	mm	in	mm	in	mm	in
<b>G185264-4</b>	-04	-04	7/16" - 20	65.5	2.58	37.2	1.46	4.0	0.16	17.3	0.68	14	0.55	14	0.55
<b>G185264-6DR</b>	-06	-06	9/16" - 18	71.0	2.80	39.0	1.54	5.5	0.22	26.0	1.02	17	0.67	17	0.67
<b>G185264-8-6</b>	-08	-06	3/4" - 16	81.0	3.19	47.9	1.89	8.0	0.31	38.5	1.52	22	0.87	17	0.67
<b>G185264-8</b>	-08	-08	3/4" - 16	87.0	3.43	48.9	1.93	8.9	0.35	41.0	1.61	22	0.87	19	0.75
<b>G185264-10-8</b>	-10	-08	7/8" - 14	96.0	3.78	57.2	2.25	10.1	0.40	49.5	1.95	27	1.06	22	0.87
<b>G185264-12</b>	-12	-12	1 1/16" - 12	110.5	4.35	65.3	2.57	14.2	0.56	53.5	2.11	32	1.26	27	1.06

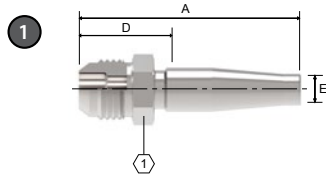

# 4203

JIC 37° Male

PART	HOSE SIZE INFO			DIMENSIONS							
	Terminal end	Hose size	Thd.	A		D		EØ		1	
1 Nipple / nipple part assembly #				mm	in	mm	in	mm	in	mm	in
<b>4203-6-6S</b>	-06	-06	9/16" - 18	69.4	2.73	37.4	1.47	7.9	0.31	17	0.67
<b>4203-8-6S</b>	-08	-08	3/4" - 16	73.5	2.89	38.4	1.51	7.9	0.31	22	0.87
<b>4203-10-8S</b>	-10	-08	7/8" - 14	79.8	3.14	41.0	1.61	9.9	0.39	22	0.87
<b>4203-12S</b>	-12	-12	1 1/16" - 12	95.2	3.75	50.1	1.97	15.5	0.61	32	1.26
<b>4203-16S</b>	-16	-16	1 5/16" - 12	110.8	4.36	60.9	2.40	20.7	0.81	38	1.50

## Reusable 1R and 2R series

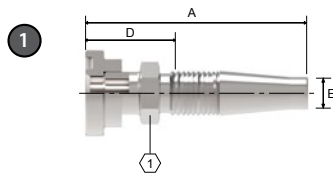

# G4614

SAE CODE 61 Flange

PART	HOSE SIZE INFO			DIMENSIONS							
	Terminal end	Hose size	Thd.	A		D		EØ		1	
1 Nipple / nipple part assembly #				mm	in	mm	in	mm	in	mm	in
<b>G4614-8</b>	30.2	-08	1/2"	79.0	3.11	40.2	1.58	10.0	0.40	19	0.75
<b>G4614-12</b>	38.0	-12	3/4"	99.5	3.92	54.3	2.14	15.5	0.61	27	1.06
<b>G4614-16-12</b>	44.0	-12	1"	99.5	3.92	54.3	2.14	15.5	0.61	27	1.06
<b>G4614-16</b>	44.0	-16	1"	103.0	4.06	53.1	2.09	20.5	0.81	32	1.26
<b>G4614-20-16</b>	50.8	-16	1 1/4"	122.5	4.82	72.7	2.86	19.0	0.75	32	1.26

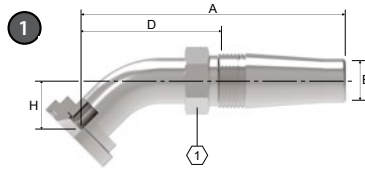

# G4645

SAE CODE 61 Flange - 45° Elbow

PART	HOSE SIZE INFO			DIMENSIONS										
	Nipple / nipple part assembly #	Terminal end	Hose size	Thd.	A		D		EØ		H		1	
					mm	in	mm	in	mm	in	mm	in	mm	in
<b>G4645-12</b>		38.1	-12	3/4"	119.5	4.70	75.5	2.97	15.5	0.61	25.0	1.00	27	1.06
<b>G4645-16</b>		44.45	-16	1"	148.7	5.85	98.9	3.89	20.7	0.82	31.7	1.24	32	1.26
<b>G4645-20-16</b>		50.8	-16	1 1/4"	148.6	5.85	98.9	3.89	19.0	0.75	31.5	1.24	32	1.26

## Reusable 1R and 2R series

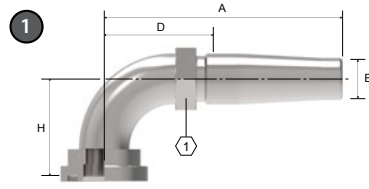

# G4690

SAE CODE 61 Flange - 90° Elbow

PART	HOSE SIZE INFO			DIMENSIONS									
	Terminal end	Hose size	Thd.	A		D		EØ		H		1	
1 Nipple / nipple part assembly #				mm	in	mm	in	mm	in	mm	in	mm	in
<b>G4690-12</b>	38.1	-12	3/4"	104.5	4.11	59.4	2.34	15.5	0.61	45.5	1.79	27	1.06
<b>G4690-16-12</b>	44.45	-12	1"	104.0	4.09	59.4	2.34	15.5	0.61	44.5	1.75	27	1.06
<b>G4690-16</b>	44.45	-16	1"	140.5	5.53	90.7	3.57	19.0	0.75	68.0	2.68	32	1.26

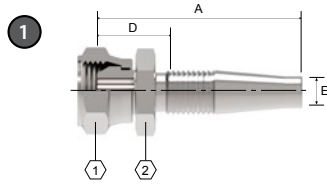

# 11.420

BSP 60° Cone Female Swivel

PART	HOSE SIZE INFO			DIMENSIONS									
	Terminal end	Hose size	Thd.	A		D		EØ		1		2	
1 Nipple / nipple part assembly #				mm	in	mm	in	mm	in	mm	in	mm	in
<b>11.420-4-4</b>	-04	-04	G 1/4"	61.5	2.42	32.0	1.26	4.0	0.16	17	0.67	17	0.67
<b>11.420-6-6</b>	-06	-06	G 3/8"	69.5	2.74	33.0	1.30	8.0	0.31	22	0.87	22	0.87
<b>11.420-8-6</b>	-08	-06	G 1/2"	69.5	2.74	33.5	1.32	8.0	0.31	27	1.06	27	1.06
<b>11.420-8-8</b>	-08	-08	G 1/2"	73.5	2.89	34.5	1.36	10.0	0.39	27	1.06	27	1.06
<b>11.420-12-12</b>	-12	-12	G 3/4"	87.5	3.44	40.0	1.57	15.5	0.61	32	1.26	32	1.26
<b>11.420-16-16</b>	-16	-16	G 1"	100.5	3.96	49.5	1.95	20.5	0.81	41	1.61	41	1.61
<b>11.420-20-16</b>	-20	-16	G 1 1/4"	100.5	3.96	49.5	1.95	20.5	0.81	50	1.97	50	1.97

## Reusable 1R and 2R series

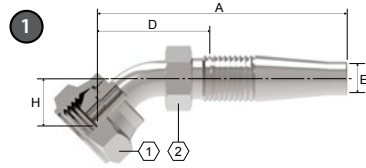

# 11.143

BSP 60° Cone Female Swivel - 45° Elbow

PART	HOSE SIZE INFO			DIMENSIONS											
	Terminal end	Hose size	Thd.	A		D		EØ		H		1		2	
1 Nipple / nipple part assembly #				mm	in	mm	in	mm	in	mm	in	mm	in	mm	in
11.143-4-4	-04	-04	G 1/4"	69.5	2.74	41	1.61	4.0	0.17	12	0.47	17	0.67	14	0.55
11.143-6-6	-06	-06	G 3/8"	81.7	3.22	49.8	1.96	7.2	0.28	14.3	0.57	22	0.87	17	0.67
11.143-8-8	-08	-08	G 1/2"	85.4	3.37	47.9	1.89	10.1	0.40	14.9	0.59	27	1.06	19	0.75
11.143-12-12	-12	-12	G 3/4"	114.5	4.51	114.6	4.51	14.2	0.56	22.6	0.89	32	1.26	27	1.06

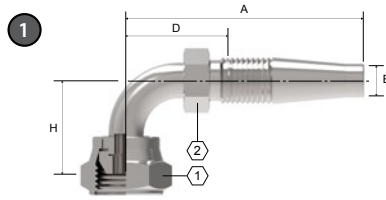

# 11.139

BSP 60° Cone Female Swivel - 90° Elbow

PART	HOSE SIZE INFO			DIMENSIONS												
	Nipple / nipple part assembly #	Terminal end	Hose size	Thd.	A		D		EØ		H		1		2	
					mm	in	mm	in	mm	in	mm	in	mm	in	mm	in
<b>11.139-4-4</b>		-04	-04	G 1/4"	62.5	2.46	34.3	1.35	4.0	0.17	22.2	0.87	17	0.67	14	0.55
<b>11.139-6-6</b>		-06	-06	G 3/8"	75.0	2.95	43.0	1.69	8.0	0.32	28.0	1.10	22	0.87	17	0.67
<b>11.139-8-8</b>		-08	-08	G 1/2"	81.0	3.19	42.2	1.66	10.0	0.40	31.8	1.25	27	1.06	19	0.75
<b>11.139-12-12</b>		-12	-12	G 3/4"	115.5	4.55	70.3	2.77	15.5	0.61	55.7	2.19	32	1.26	27	1.06



## Reusable 1R and 2R series

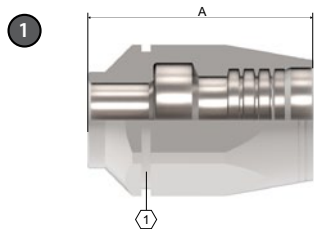

# 1R & 2R

Reusable socket

PART	HOSE SIZE INFO		DIMENSIONS				WEIGHT	
	DN	Dash Size	A		①		Weight	
1R sockets for 1 Wire Braid			mm	in	mm	in	kg	lb
<b>1R4</b>	6	-04	43.0	1.69	19	0.75	0.05	0.11
<b>1R6</b>	10	-06	48.9	1.93	24	0.94	0.08	0.17
<b>1R8</b>	12	-08	50.6	1.99	27	1.06	0.10	0.21
<b>1R12</b>	20	-12	61.2	2.41	36	1.42	0.22	0.49
<b>1R16</b>	25	-16	74.9	2.95	46	1.81	0.39	0.87
2R sockets for 2 Wire Braid	DN	Dash Size	A		①		Weight	
<b>2R4</b>	6	-04	44.0	1.73	22	0.87	0.07	0.15
<b>2R6</b>	10	-06	48.9	1.93	27	1.06	0.12	0.26
<b>2R8</b>	12	-08	51.1	2.01	30	1.18	0.15	0.32
<b>2R12</b>	20	-12	62.7	2.47	38	1.50	0.25	0.55
<b>2R16PD</b>	25	-16	74.9	2.95	46	1.81	0.43	0.95

Winner by Danfoss

## **Braided and spiral fittings**

Winner 2pc  
Standard Fitting Series



# Winner

## Braided and spiral – standard fittings

### 00110

Crimp Socket - 1 wire

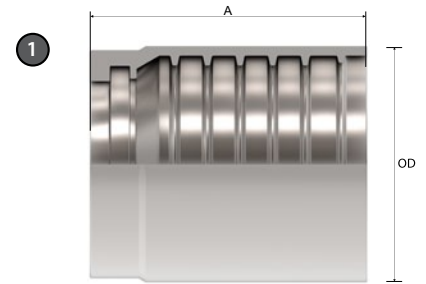

PART Winner 2pc part #	HOSE SIZE INFO		DIMENSIONS				WEIGHT	
	DN	Dash Size	A		OD		Weight	
			mm	in	mm	in	kg	lb
<b>00110-04AEWZD</b>	6	-04	27.4	1.08	21.0	0.83	0.03	0.07
<b>00110-05AEWZD</b>	8	-05	28.0	1.10	21.5	0.85	0.03	0.06
<b>00110-06AEWZD</b>	10	-06	30.0	1.18	24.3	0.96	0.04	0.08
<b>00110-08AEWZD</b>	12	-08	34.0	1.34	28.0	1.10	0.05	0.10
<b>00110-10AEWZD</b>	16	-10	37.0	1.46	31.3	1.23	0.06	0.13
<b>00110-12AEWZD</b>	19	-12	42.0	1.65	35.5	1.40	0.08	0.17
<b>00110-16AEWZD</b>	25	-16	51.0	2.01	43.5	1.71	0.13	0.28
<b>00110-20EWZD</b>	31	-20	59.0	2.32	52.0	2.05	0.21	0.46
<b>00110-24EWZD</b>	38	-24	74.0	2.91	58.0	2.28	0.27	0.58
<b>00110-32EWZD</b>	51	-32	78.0	3.07	72.0	2.83	0.39	0.86

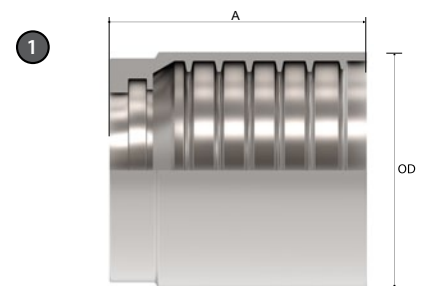

### 03310

Crimp Socket - 2 wire

PART Winner 2pc part #	HOSE SIZE INFO		DIMENSIONS				WEIGHT	
	DN	Dash Size	A		OD		Weight	
			mm	in	mm	in	kg	lb
<b>03310-04EWZD</b>	6	-04	30.5	1.20	23.0	0.91	0.04	0.09
<b>03310-05EWZD</b>	8	-05	30.0	1.18	24.0	0.94	0.04	0.08
<b>03310-06EWZD</b>	10	-06	32.0	1.26	26.0	1.02	0.04	0.09
<b>03310-08EWZD</b>	12	-08	34.0	1.34	29.0	1.14	0.05	0.10
<b>03310-10AEWZD</b>	16	-10	35.0	1.38	34.5	1.36	0.06	0.14
<b>03310-12EWZD</b>	19	-12	42.0	1.65	37.0	1.46	0.08	0.18
<b>03310-16EWZD</b>	25	-16	51.0	2.01	46.7	1.84	0.15	0.33
<b>03310-20AEWZD</b>	32	-20	55.0	2.16	59.0	2.32	0.26	0.57
<b>03310-24AEWZD</b>	38	-24	66.0	2.60	67.0	2.64	0.43	0.94
<b>03310-32AEWZD</b>	51	-32	72.0	2.83	80.0	3.15	0.61	1.34

Braided and spiral – standard fittings

# 4W

Crimp Socket - 3 Wire and 4SP

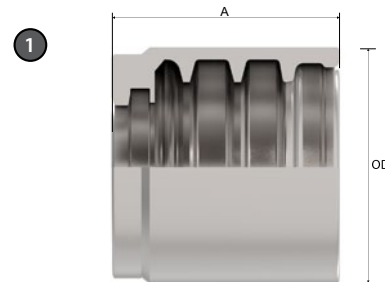

PART		HOSE SIZE INFO		DIMENSIONS				WEIGHT	
Socket part #	SAP part #	DN	Dash Size	A		OD		Weight	
				mm	in	mm	in	kg	lb
<b>4W6</b>	12010139	10	-06	33.0	1.30	32.2	1.27	0.09	0.19
<b>4W8</b>	12006509	12	-08	34.5	1.36	36.3	1.43	0.09	0.21
<b>4W10</b>	12006510	16	-10	37.5	1.48	40.2	1.58	0.11	0.24
<b>4W12</b>	12006511	19	-12	42.5	1.67	45.5	1.79	0.17	0.37
<b>4W16</b>	12006512	25	-16	51.0	2.01	52.5	2.07	0.22	0.48

# 000T8

Crimp Socket - Textile and Thermoplastic

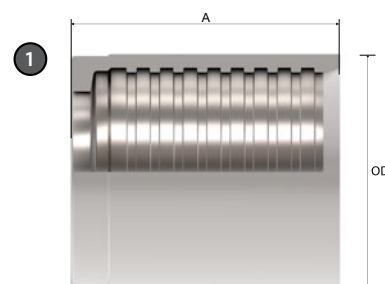

PART	HOSE SIZE INFO		DIMENSIONS				WEIGHT	
Winner 2pc part #	DN	Dash Size	A		OD		Weight	
			mm	in	mm	in	kg	lb
<b>000T8-02EWZD</b>	3	-02	20.5	0.81	12.1	0.47	0.02	0.05
<b>000T8-03EWZD</b>	5	-03	23.0	0.91	17.2	0.68	0.02	0.06
<b>000T8-04EWZD</b>	6	-04	30.5	1.20	21.0	0.83	0.03	0.06
<b>000T8-05EWZD</b>	8	-05	30.0	1.18	22.0	0.87	0.03	0.07
<b>000T8-06EWZD</b>	10	-06	32.0	1.26	24.4	0.96	0.04	0.08
<b>000T8-08EWZD</b>	12	-08	34.0	1.34	27.8	1.09	0.05	0.10
<b>000T8-10EWZD</b>	16	-10	37.0	1.46	34.6	1.36	0.06	0.13
<b>000T8-12EWZD</b>	19	-12	42.0	1.65	33.3	1.31	0.08	0.17
<b>000T8-16EWZD</b>	25	-16	51.0	2.01	44.8	1.76	0.13	0.28

# Winner

## Braided and spiral – standard fittings

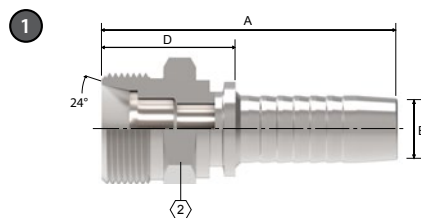

# 10411

DIN 24° DKO Light Male

PART		HOSE SIZE INFO				DIMENSIONS							WEIGHT		
Winner 2pc part #	Terminal End	Thread	Tube O.D.	Hose Size		A		D Cut Off Factor		E Ø		2		Weight	
				DN	Dash Size	mm	in	mm	in	mm	in	mm	in	kg	lb
<b>10411-12-04Z</b>	-12	M12 x 1.5	6	6	-04	48.5	1.91	20.5	0.81	4.0	0.16	12	0.47	0.015	0.033
<b>10411-14-04Z</b>	-14	M14 x 1.5	8	6	-04	48.5	1.91	20.5	0.81	4.0	0.16	14	0.55	0.020	0.044
<b>10411-14-05Z</b>	-14	M14 x 1.5	8	8	-05	49.5	1.95	21.5	0.85	5.5	0.22	14	0.55	0.020	0.044
<b>10411-16-04Z</b>	-16	M16 x 1.5	10	6	-04	50.5	1.99	22.5	0.89	4.0	0.16	17	0.67	0.025	0.055
<b>10411-16-05Z</b>	-16	M16 x 1.5	10	8	-05	50.5	1.99	22.5	0.89	5.5	0.22	17	0.67	0.025	0.055
<b>10411-16-06Z</b>	-16	M16 x 1.5	10	10	-06	52.5	2.07	22.5	0.89	7.0	0.28	17	0.67	0.034	0.075
<b>10411-18-04Z</b>	-18	M18 x 1.5	12	6	-04	51.5	2.03	23.5	0.93	4.0	0.16	19	0.75	0.030	0.066
<b>10411-18-05Z</b>	-18	M18 x 1.5	12	8	-05	51.5	2.03	23.5	0.93	5.5	0.22	19	0.75	0.030	0.066
<b>10411-18-06Z</b>	-18	M18 x 1.5	12	10	-06	52.5	2.07	22.5	0.89	7.0	0.28	19	0.75	0.035	0.077
<b>10411-18-08Z</b>	-18	M18 x 1.5	12	12	-08	55.5	2.19	24.0	0.95	10.0	0.39	19	0.75	0.045	0.099
<b>10411-22-06Z</b>	-22	M22 x 1.5	15	10	-06	54.5	2.15	24.5	0.96	7.0	0.28	24	0.94	0.050	0.110
<b>10411-22-08Z</b>	-22	M22 x 1.5	15	12	-08	57.5	2.26	26.0	1.02	10.0	0.39	24	0.94	0.060	0.132
<b>10411-26-08Z</b>	-26	M26 x 1.5	18	12	-08	58.0	2.28	26.5	1.04	10.0	0.39	27	1.06	0.076	0.167
<b>10411-26-10Z</b>	-26	M26 x 1.5	18	16	-10	60.5	2.38	26.5	1.04	12.0	0.47	27	1.06	0.080	0.176
<b>10411-30-12Z</b>	-30	M30 x 2	22	19	-12	68.5	2.70	30.0	1.18	15.0	0.59	32	1.26	0.122	0.268
<b>10411-36-12Z</b>	-36	M36 x 2	28	19	-12	69.5	2.75	31.0	1.22	15.0	0.59	38	1.50	0.164	0.361
<b>10411-36-16Z</b>	-36	M36 x 2	28	25	-16	78.5	3.09	31.5	1.24	21.0	0.83	38	1.50	0.178	0.392
<b>10411-45-20Z</b>	-45	M45 x 2	35	31	-20	91.0	3.58	37.0	1.46	27.0	1.06	46	1.81	0.310	0.682
<b>10411-52-24Z</b>	-52	M52 x 2	42	38	-24	106.0	4.17	38.0	1.50	32.0	1.26	55	2.17	0.460	1.012

# 20411

DIN 24° DKO Light Female Swivel

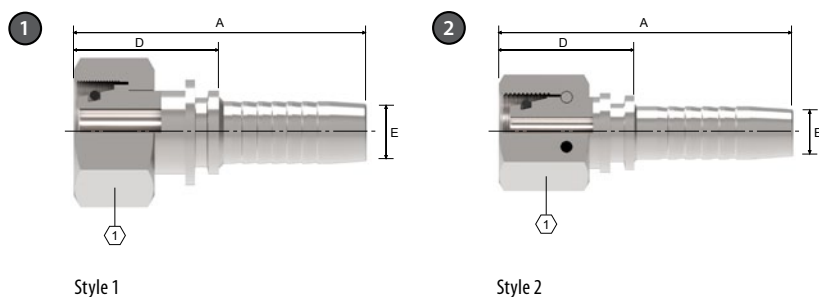

PART	STY.	HOSE SIZE INFO					DIMENSIONS							WEIGHT		
		Ter- minal End	Thread	Tube O.D.	Hose Size		A		D Cut Off Factor		E Ø		1		Weight	
Winner 2pc part #					DN	Dash Size	mm	in	mm	in	mm	in	mm	in	kg	lb
<b>20411-12-04WZ</b>	2	-12	M12 x 1.5	6	6	-04	50.0	1.97	22.0	0.87	4.0	0.16	17	0.67	0.032	0.071
<b>20411-14-04TZ</b>	1	-14	M14 x 1.5	8	6	-04	50.5	1.99	22.5	0.89	4.0	0.16	17	0.67	0.030	0.066
<b>20411-14-05WZ</b>	2	-14	M14 x 1.5	8	8	-05	50.5	1.99	22.5	0.89	5.5	0.22	17	0.67	0.032	0.071
<b>20411-14-06WZ</b>	2	-14	M14 x 1.5	8	10	-06	53.0	2.09	23.0	0.91	7.0	0.28	17	0.67	0.035	0.077
<b>20411-16-04TZ</b>	1	-16	M16 x 1.5	10	6	-04	48.5	1.91	20.5	0.81	4.0	0.16	19	0.75	0.032	0.071
<b>20411-16-05TZ</b>	1	-16	M16 x 1.5	10	8	-05	50.0	1.97	22.0	0.87	5.5	0.22	19	0.75	0.038	0.084
<b>20411-16-06WZ</b>	2	-16	M16 x 1.5	10	10	-06	53.5	2.11	23.5	0.93	7.0	0.28	19	0.75	0.044	0.097
<b>20411-18-04TZ</b>	1	-18	M18 x 1.5	12	6	-04	52.5	2.07	24.5	0.96	4.0	0.16	22	0.87	0.047	0.104
<b>20411-18-05TZ</b>	1	-18	M18 x 1.5	12	8	-05	52.5	2.07	24.5	0.96	5.5	0.22	22	0.87	0.055	0.121
<b>20411-18-06TZ</b>	1	-18	M18 x 1.5	12	10	-06	57.5	2.26	27.5	1.08	7.0	0.28	22	0.87	0.055	0.121
<b>20411-18-08WZ</b>	2	-18	M18 x 1.5	12	12	-08	56.0	2.2	24.5	0.96	10.0	0.39	22	0.87	0.064	0.141
<b>20411-22-10WZ</b>	2	-22	M22 x 1.5	15	16	-10	60.0	2.36	26.0	1.02	12.0	0.47	27	1.06	0.105	0.231
<b>20411-22-04TZ</b>	1	-22	M22 x 1.5	15	6	-04	54.5	2.15	26.5	1.04	4.0	0.16	27	1.06	0.075	0.165
<b>20411-22-05TZ</b>	1	-22	M22 x 1.5	15	8	-05	54.5	2.15	26.5	1.04	5.5	0.22	27	1.06	0.078	0.172
<b>20411-22-06TZ</b>	1	-22	M22 x 1.5	15	10	-06	56.5	2.22	26.5	1.04	7.0	0.28	27	1.06	0.084	0.185
<b>20411-22-08TZ</b>	1	-22	M22 x 1.5	15	12	-08	60.5	2.38	29.0	1.14	10.0	0.39	27	1.06	0.076	0.168
<b>20411-26-10TZ</b>	1	-26	M26 x 1.5	18	16	-10	64.0	2.52	30.0	1.18	12.0	0.47	32	1.26	0.120	0.265
<b>20411-26-12WZ</b>	2	-26	M26 x 1.5	18	19	-12	67.0	2.64	28.5	1.12	15.0	0.59	32	1.26	0.145	0.32
<b>20411-26-08TZ</b>	1	-26	M26 x 1.5	18	12	-08	59.0	2.32	27.5	1.08	10.0	0.39	32	1.26	0.118	0.26
<b>20411-30-10TZ</b>	1	-30	M30 x 2	22	16	-10	65.0	2.56	31.0	1.22	12.0	0.47	36	1.42	0.150	0.331
<b>20411-30-12TZ</b>	1	-30	M30 x 2	22	19	-12	72.5	2.85	34.0	1.34	15.0	0.59	36	1.42	0.185	0.408
<b>20411-30-16WZ</b>	2	-30	M30 x 2	22	25	-16	77.5	3.05	30.5	1.2	21.0	0.83	36	1.42	0.212	0.467
<b>20411-36-12TZ</b>	1	-36	M36 x 2	28	19	-12	71.5	2.81	33.0	1.3	15.0	0.59	41	1.61	0.205	0.452
<b>20411-36-16WZ</b>	2	-36	M36 x 2	28	25	-16	77.0	3.03	30.0	1.18	21.0	0.83	41	1.61	0.235	0.518
<b>20411-45-16TZ</b>	1	-45	M45 x 2	35	25	-16	84.0	3.31	37.0	1.46	21.0	0.83	50	1.97	0.433	0.955
<b>20411-45-20TZ</b>	1	-45	M45 x 2	35	31	-20	91.5	3.6	37.5	1.48	27.0	1.06	50	1.97	0.485	1.069
<b>20411-52-20TZ</b>	1	-52	M52 x 2	42	31	-20	92.5	3.64	38.5	1.52	27.0	1.06	60	2.36	0.500	1.102
<b>20411-52-24TZ</b>	1	-52	M52 x 2	42	38	-24	106.5	4.19	38.5	1.52	32.0	1.26	60	2.36	0.620	1.367

1 Denotes Style 1 design

2 Denotes Style 2 wire nut design

# Winner

## Braided and spiral – standard fittings

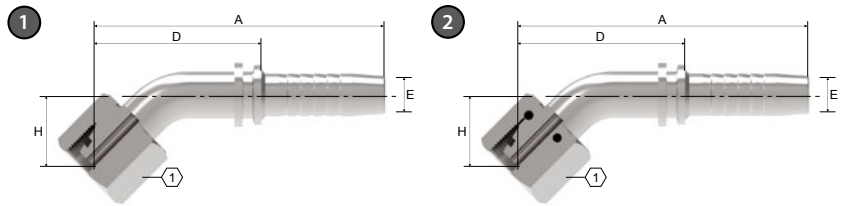

# 20441

DIN 24° DKO Light Female Swivel - 45° Elbow

Style 1

Style 2

PART	HOSE SIZE INFO						DIMENSIONS									WEIGHT			
	Winner 2pc part #	Terminal End	Thread	Tube O.D.	Hose Size	Dash Size	A		D Cut Off Factor		E Ø		H		①		Weight		
STY.				DN		mm	in	mm	in	mm	in	mm	in	mm	in	mm	in	kg	lb
20441-12-04WZ	②	-12	M12 x 1.5	6	6	-04	64.0	2.52	36.0	1.42	4.0	0.16	15.1	0.59	17	0.67	0.040	0.088	
20441-14-04TZ	①	-14	M14 x 1.5	8	6	-04	66.1	2.60	38.1	1.50	4.0	0.16	16.0	0.63	17	0.67	0.040	0.088	
20441-16-04TZ	①	-16	M16 x 1.5	10	6	-04	66.1	2.60	38.1	1.50	4.0	0.16	16.0	0.63	19	0.75	0.050	0.088	
20441-16-05TZ	①	-16	M16 x 1.5	10	8	-05	68.3	2.69	40.3	1.59	5.5	0.22	17.0	0.67	19	0.75	0.054	0.119	
20441-16-06WZ	②	-16	M16 x 1.5	10	10	-06	70.3	2.77	40.3	1.59	7.0	0.28	17.0	0.67	19	0.75	0.058	0.128	
20441-18-05TZ	①	-18	M18 x 1.5	12	8	-05	68.3	2.69	40.3	1.59	5.5	0.22	17.0	0.67	22	0.87	0.070	0.154	
20441-18-06TZ	①	-18	M18 x 1.5	12	10	-06	75.0	2.95	45.0	1.77	7.0	0.28	18.5	0.73	22	0.87	0.070	0.154	
20441-18-08WZ	②	-18	M18 x 1.5	12	12	-08	75.7	2.98	44.2	1.74	10.0	0.39	18.7	0.74	22	0.87	0.086	0.190	
20441-22-10WZ	②	-22	M22 x 1.5	15	16	-10	83.0	3.27	49.0	1.93	12.0	0.47	22.2	0.87	27	1.06	0.125	0.276	
20441-22-06TZ	①	-22	M22 x 1.5	15	10	-06	72.0	2.83	42.0	1.65	7.0	0.28	18.0	0.71	27	1.06	0.096	0.212	
20441-22-08TZ	①	-22	M22 x 1.5	15	12	-08	80.3	3.16	48.8	1.92	10.0	0.39	20.0	0.79	27	1.06	0.105	0.231	
20441-26-10TZ	①	-26	M26 x 1.5	18	16	-10	92.0	3.62	58.0	2.28	12.0	0.47	23.5	0.93	32	1.26	0.178	0.392	
20441-26-12WZ	②	-26	M26 x 1.5	18	19	-12	99.9	3.93	61.4	2.42	15.0	0.59	24.6	0.97	32	1.26	0.210	0.463	
20441-26-08TZ	①	-26	M26 x 1.5	18	12	-08	78.8	3.10	47.3	1.86	10.0	0.39	21.0	0.83	32	1.26	0.154	0.340	
20441-30-10TZ	①	-30	M30 x 2	22	16	-10	90.4	3.56	56.4	2.22	12.0	0.47	24.1	0.95	36	1.42	0.196	0.432	
20441-30-12TZ	①	-30	M30 x 2	22	19	-12	101.7	4.00	63.2	2.49	15.0	0.59	25.6	1.01	36	1.42	0.240	0.529	
20441-36-12TZ	①	-36	M36 x 2	28	19	-12	100.0	3.94	61.5	2.42	15.0	0.59	25.6	1.01	41	1.61	0.360	0.794	
20441-36-16WZ	②	-36	M36 x 2	28	25	-16	124.6	4.91	77.6	3.06	21.0	0.83	32.0	1.26	41	1.61	0.388	0.855	
20441-45-16TZ	①	-45	M45 x 2	35	25	-16	124.5	4.90	77.5	3.05	21.0	0.83	32.0	1.26	50	1.97	0.590	1.301	
20441-45-20TZ	①	-45	M45 x 2	35	31	-20	153.8	6.06	99.8	3.93	27.0	1.06	39.1	1.54	50	1.97	0.716	1.579	
20441-52-20TZ	①	-52	M52 x 2	42	31	-20	156.0	6.14	102.0	4.02	27.0	1.06	39.8	1.57	60	2.36	0.813	1.792	
20441-52-24TZ	①	-52	M52 x 2	42	38	-24	182.5	7.19	114.5	4.51	32.0	1.26	43.7	1.72	60	2.36	1.100	2.425	

① Denotes Style 1 design

② Denotes Style 2 wire nut design



Braided and spiral – standard fittings

# 20491

DIN 24° DKO Light Female Swivel - 90° Elbow

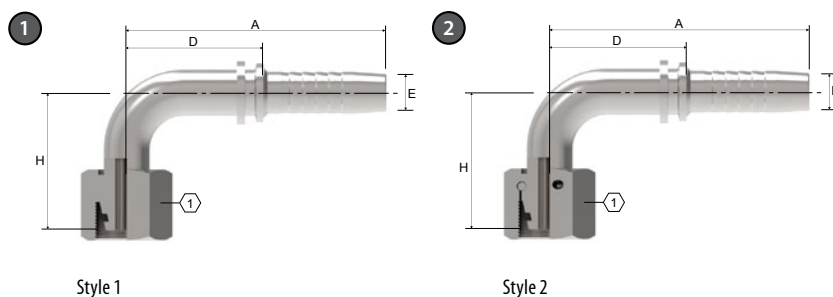

PART	HOSE SIZE INFO						DIMENSIONS										WEIGHT	
	Winner 2pc part #	Ter-minal End	Thread	Tube O.D.	Hose Size	Dash Size	A		D Cut Off Factor		E Ø		H		1		Weight	
	STY.				DN		mm	in	mm	in	mm	in			mm	in	kg	lb
<b>20491-12-04WZ</b>	2	-12	M12 x 1.5	6	6	-04	55.0	2.17	27.0	1.06	4.0	0.16	30.0	1.18	17	0.67	0.040	0.088
<b>20491-14-04WZ</b>	2	-14	M14 x 1.5	8	6	-04	58.0	2.28	30.0	1.18	4.0	0.16	30.5	1.20	17	0.67	0.042	0.093
<b>20491-14-05WZ</b>	2	-14	M14 x 1.5	8	8	-05	58.0	2.28	30.0	1.18	5.5	0.22	30.5	1.20	17	0.67	0.046	0.101
<b>20491-14-06WZ</b>	2	-14	M14 x 1.5	8	10	-06	60.0	2.36	30.0	1.18	7.0	0.28	30.5	1.20	17	0.67	0.050	0.110
<b>20491-16-04TZ</b>	1	-16	M16 x 1.5	10	6	-04	58.0	2.28	30.0	1.18	4.0	0.16	30.5	1.20	19	0.75	0.050	0.110
<b>20491-16-05TZ</b>	1	-16	M16 x 1.5	10	8	-05	60.0	2.36	32.0	1.26	5.5	0.22	33.0	1.30	19	0.75	0.070	0.154
<b>20491-16-06WZ</b>	2	-16	M16 x 1.5	10	10	-06	65.0	2.56	35.0	1.38	7.0	0.28	33.0	1.30	19	0.75	0.064	0.141
<b>20491-18-04TZ</b>	1	-18	M18 x 1.5	12	6	-04	58.0	2.28	30.0	1.18	4.0	0.16	30.5	1.20	22	0.87	0.074	0.163
<b>20491-18-05TZ</b>	1	-18	M18 x 1.5	12	8	-05	61.0	2.40	33.0	1.30	5.5	0.22	33.5	1.32	22	0.87	0.077	0.170
<b>20491-18-06TZ</b>	1	-18	M18 x 1.5	12	10	-06	67.0	2.64	37.0	1.46	7.0	0.28	36.0	1.42	22	0.87	0.075	0.165
<b>20491-18-08WZ</b>	2	-18	M18 x 1.5	12	12	-08	70.5	2.78	39.0	1.54	10.0	0.39	37.0	1.46	22	0.87	0.090	0.198
<b>20491-22-10WZ</b>	2	-22	M22 x 1.5	15	16	-10	79.0	3.11	45.0	1.77	11.9	0.47	44.5	1.75	27	1.06	0.145	0.320
<b>20491-22-05TZ</b>	1	-22	M22 x 1.5	15	8	-05	61.0	2.40	33.0	1.30	5.5	0.22	34.5	1.36	27	1.06	0.092	0.203
<b>20491-22-06TZ</b>	1	-22	M22 x 1.5	15	10	-06	64.5	2.54	34.5	1.36	7.0	0.28	36.0	1.42	27	1.06	0.110	0.243
<b>20491-22-08TZ</b>	1	-22	M22 x 1.5	15	12	-08	73.5	2.89	42.0	1.65	10.0	0.39	41.5	1.63	27	1.06	0.126	0.278
<b>20491-26-10TZ</b>	1	-26	M26 x 1.5	18	16	-10	85.2	3.35	51.2	2.02	12.0	0.47	51.5	2.03	32	1.26	0.210	0.463
<b>20491-26-12WZ</b>	2	-26	M26 x 1.5	18	19	-12	94.0	3.70	55.5	2.19	15.0	0.59	51.5	2.03	32	1.26	0.242	0.534
<b>20491-26-08TZ</b>	1	-26	M26 x 1.5	18	12	-08	71.0	2.80	39.5	1.56	10.0	0.39	42.9	1.69	32	1.26	0.160	0.353
<b>20491-30-10TZ</b>	1	-30	M30 x 2	22	16	-10	83.0	3.27	49.0	1.93	12.0	0.47	51.5	2.03	36	1.42	0.255	0.562
<b>20491-30-12TZ</b>	1	-30	M30 x 2	22	19	-12	95.5	3.76	57.0	2.24	15.0	0.59	56.0	2.20	36	1.42	0.293	0.646
<b>20491-30-16WZ</b>	2	-30	M30 x 2	22	25	-16	112.5	4.43	65.5	2.58	21.0	0.83	61.5	2.42	36	1.42	0.380	0.838
<b>20491-36-10TZ</b>	1	-36	M36 x 2	28	16	-10	83.0	3.27	49.0	1.93	12.0	0.47	56.5	2.22	41	1.61	0.290	0.639
<b>20491-36-12TZ</b>	1	-36	M36 x 2	28	19	-12	93.8	3.69	55.3	2.18	15.0	0.59	56.0	2.20	41	1.61	0.422	0.930
<b>20491-36-16WZ</b>	2	-36	M36 x 2	28	25	-16	118.0	4.65	71.0	2.80	21.0	0.83	68.5	2.70	41	1.61	0.450	0.992
<b>20491-45-16TZ</b>	1	-45	M45 x 2	35	25	-16	118.0	4.65	71.0	2.80	21.0	0.83	69.5	2.74	50	1.97	0.660	1.455
<b>20491-45-24WZ</b>	2	-45	M45 x 2	35	38	-24	169.5	6.67	101.5	4.00	32.0	1.26	91.5	3.60	50	1.97	0.900	1.984
<b>20491-45-20TZ</b>	1	-45	M45 x 2	35	31	-20	145.5	5.73	91.5	3.60	27.0	1.06	86.0	3.39	50	1.97	0.850	1.874
<b>20491-52-20TZ</b>	1	-52	M52 x 2	42	31	-20	147.0	5.79	93.0	3.66	27.0	1.06	87.0	3.43	60	2.36	0.913	2.013
<b>20491-52-24TZ</b>	1	-52	M52 x 2	42	38	-24	177.4	6.98	109.4	4.31	32.0	1.26	100.5	3.96	60	2.36	1.470	3.241

1 Denotes Style 1 design

2 Denotes Style 2 wire nut design



# Winner

## Braided and spiral – standard fittings

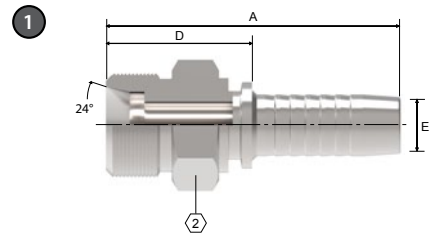

# 10511

DIN 24° DKO Heavy Male

PART	HOSE SIZE INFO					DIMENSIONS								WEIGHT	
	Winner 2pc part #	Terminal End	Thread	Tube O.D.	Hose Size	A		D Cut Off Factor		E Ø		2		Weight	
				DN	Dash Size	mm	in	mm	in	mm	in	mm	in	kg	lb
<b>10511-14-04Z</b>	-14	M14 x 1.5	6	6	-04	52.5	2.07	24.5	0.96	4.0	0.16	14	0.55	0.025	0.055
<b>10511-16-04Z</b>	-16	M16 x 1.5	8	6	-04	54.5	2.15	26.5	1.04	4.0	0.16	17	0.67	0.036	0.079
<b>10511-18-04Z</b>	-18	M18 x 1.5	10	6	-04	54.5	2.15	26.5	1.04	4.0	0.16	19	0.75	0.040	0.088
<b>10511-18-06Z</b>	-18	M18 x 1.5	10	10	-06	56.5	2.22	26.5	1.04	7.0	0.28	19	0.75	0.045	0.099
<b>10511-20-05Z</b>	-20	M20 x 1.5	12	8	-05	55.0	2.17	27.0	1.06	5.5	0.22	22	0.87	0.052	0.114
<b>10511-20-06Z</b>	-20	M20 x 1.5	12	10	-06	56.5	2.22	26.5	1.04	7.0	0.28	22	0.87	0.060	0.132
<b>10511-22-06Z</b>	-22	M22 x 1.5	14	10	-06	60.5	2.38	30.5	1.20	7.0	0.28	24	0.94	0.070	0.154
<b>10511-22-08Z</b>	-22	M22 x 1.5	14	12	-08	62.5	2.46	31.0	1.22	10.0	0.39	24	0.94	0.080	0.176
<b>10511-24-08Z</b>	-24	M24 x 1.5	16	12	-08	63.0	2.48	31.5	1.24	10.0	0.39	27	1.06	0.090	0.198
<b>10511-30-10Z</b>	-30	M30 x 2	20	16	-10	68.5	2.70	34.5	1.36	12.0	0.47	32	1.26	0.140	0.308
<b>10511-30-12Z</b>	-30	M30 x 2	20	19	-12	74.5	2.93	36.0	1.42	15.0	0.59	32	1.26	0.150	0.330
<b>10511-36-12Z</b>	-36	M36 x 2	25	19	-12	79.0	3.11	40.5	1.59	15.0	0.59	41	1.61	0.255	0.561
<b>10511-36-16Z</b>	-36	M36 x 2	25	25	-16	88.5	3.48	41.5	1.63	21.0	0.83	38	1.50	0.245	0.539
<b>10511-42-16Z</b>	-42	M42 x 2	30	25	-16	91.0	3.58	44.0	1.73	21.0	0.83	46	1.81	0.336	0.739

Braided and spiral – standard fittings

# 20511

DIN 24° DKO Heavy Female Swivel

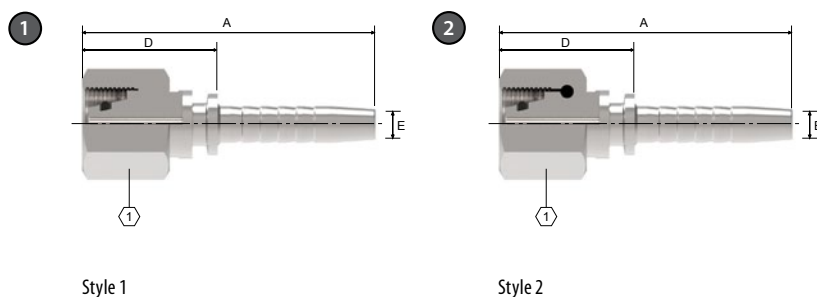

PART	HOSE SIZE INFO						DIMENSIONS						WEIGHT			
	Winner 2pc part #	Ter-minal End	Thread	Tube O.D.	Hose Size		A		D Cut Off Factor		E Ø		Weight			
STY.				DN	Dash Size	mm	in	mm	in	mm	in	mm	in	kg	lb	
<b>20511-14-04WZ</b>	2	-14	M14 x 1.5	6	6	-04	51.0	2.01	23.0	0.91	4.0	0.16	17	0.67	0.030	0.066
<b>20511-16-04TZ</b>	1	-16	M16 x 1.5	8	6	-04	48.5	1.91	20.5	0.81	4.0	0.16	19	0.75	0.026	0.057
<b>20511-16-05WZ</b>	2	-16	M16 x 1.5	8	8	-05	51.0	2.01	23.0	0.91	5.5	0.22	19	0.75	0.047	0.104
<b>20511-16-06WZ</b>	2	-16	M16 x 1.5	8	10	-06	53.0	2.09	23.0	0.91	7.0	0.28	19	0.75	0.045	0.099
<b>20511-18-04TZ</b>	1	-18	M18 x 1.5	10	6	-04	53.5	2.11	25.5	1.00	4.0	0.16	22	0.87	0.053	0.117
<b>20511-18-05TZ</b>	1	-18	M18 x 1.5	10	8	-05	53.5	2.11	25.5	1.00	5.5	0.22	22	0.87	0.051	0.112
<b>20511-18-06TZ</b>	1	-18	M18 x 1.5	10	10	-06	56.0	2.20	26.0	1.02	7.0	0.28	22	0.87	0.054	0.119
<b>20511-20-04TZ</b>	1	-20	M20 x 1.5	12	6	-04	54.5	2.15	26.5	1.04	4.0	0.16	24	0.94	0.060	0.132
<b>20511-20-05TZ</b>	1	-20	M20 x 1.5	12	8	-05	54.5	2.15	26.5	1.04	5.5	0.22	24	0.94	0.065	0.143
<b>20511-20-06TZ</b>	1	-20	M20 x 1.5	12	10	-06	56.5	2.22	26.5	1.04	7.0	0.28	24	0.94	0.065	0.143
<b>20511-20-08WZ</b>	2	-20	M20 x 1.5	12	12	-08	57.0	2.24	25.5	1.00	10.0	0.39	24	0.94	0.076	0.168
<b>20511-22-06TZ</b>	1	-22	M22 x 1.5	14	10	-06	56.5	2.22	26.5	1.04	7.0	0.28	27	1.06	0.090	0.198
<b>20511-22-08TZ</b>	1	-22	M22 x 1.5	14	12	-08	59.0	2.32	27.5	1.08	10.0	0.39	27	1.06	0.088	0.194
<b>20511-24-10WZ</b>	2	-24	M24 x 1.5	16	16	-10	60.5	2.38	26.5	1.04	12.0	0.47	30	1.18	0.126	0.278
<b>20511-24-06TZ</b>	1	-24	M24 x 1.5	16	10	-06	57.0	2.24	27.0	1.06	7.0	0.28	30	1.18	0.100	0.220
<b>20511-24-08TZ</b>	1	-24	M24 x 1.5	16	12	-08	59.0	2.32	27.5	1.08	10.0	0.39	30	1.18	0.106	0.234
<b>20511-30-10TZ</b>	1	-30	M30 x 2	20	16	-10	67.0	2.64	33.0	1.30	12.0	0.47	36	1.42	0.180	0.397
<b>20511-30-12TZ</b>	1	-30	M30 x 2	20	19	-12	73.5	2.89	35.0	1.38	15.0	0.59	36	1.42	0.195	0.430
<b>20511-30-08TZ</b>	1	-30	M30 x 2	20	12	-08	64.0	2.52	32.5	1.28	10.0	0.39	36	1.42	0.170	0.375
<b>20511-36-12TZ</b>	1	-36	M36 x 2	25	19	-12	73.5	2.89	35.0	1.38	15.0	0.59	46	1.81	0.300	0.661
<b>20511-36-16WZ</b>	2	-36	M36 x 2	25	25	-16	78.5	3.09	31.5	1.24	21.0	0.83	46	1.81	0.330	0.728
<b>20511-42-12TZ</b>	1	-42	M42 x 2	30	19	-12	76.0	2.99	37.5	1.48	15.0	0.59	50	1.97	0.362	0.798
<b>20511-42-16TZ</b>	1	-42	M42 x 2	30	25	-16	85.5	3.37	38.5	1.52	21.0	0.83	50	1.97	0.370	0.816
<b>20511-42-20WZ</b>	2	-42	M42 x 2	30	31	-20	85.5	3.37	31.5	1.24	27.0	1.06	50	1.97	0.404	0.891
<b>20511-52-20TZ</b>	1	-52	M52 x 2	38	31	-20	95.5	3.76	41.5	1.63	27.0	1.06	60	2.36	0.626	1.380
<b>20511-52-24TZ</b>	1	-52	M52 x 2	38	38	-24	109.5	4.31	41.5	1.63	32.0	1.26	60	2.36	0.700	1.543

1 Denotes Style 1 design

2 Denotes Style 2 wire nut design

# Winner

## Braided and spiral – standard fittings

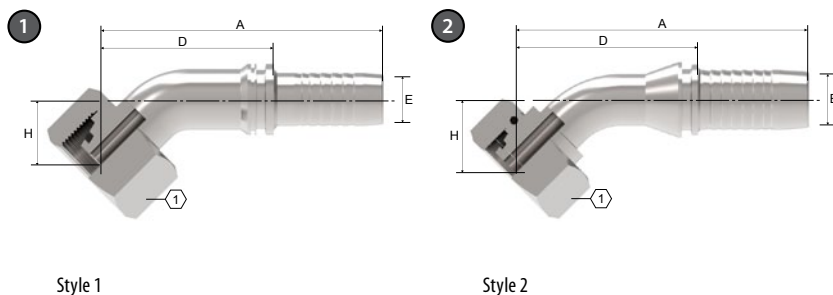

# 20541

DIN 24° DKO Heavy Female Swivel - 45° Elbow

Style 1

Style 2

PART		HOSE SIZE INFO					DIMENSIONS										WEIGHT	
Winner 2pc part #		Terminal End	Thread	Tube O.D.	Hose Size		A		D Cut Off Factor		E Ø		H		1		Weight	
	STY.				DN	Dash Size	mm	in	mm	in	mm	in	mm	in	mm	in	kg	lb
<b>20541-16-04TZ</b>	1	-16	M16 x 1.5	8	6	-04	66.4	2.61	38.4	1.51	4.0	0.16	16.3	0.64	19	0.75	0.045	0.099
<b>20541-18-04TZ</b>	1	-18	M18 x 1.5	10	6	-04	67.1	2.64	39.1	1.54	4.0	0.16	17.0	0.67	22	0.87	0.058	0.128
<b>20541-18-06TZ</b>	1	-18	M18 x 1.5	10	10	-06	73.8	2.91	43.8	1.72	7.0	0.28	17.3	0.68	22	0.87	0.062	0.137
<b>20541-20-06TZ</b>	1	-20	M20 x 1.5	12	10	-06	72.5	2.85	42.5	1.67	7.0	0.28	18.5	0.73	24	0.94	0.085	0.187
<b>20541-22-08TZ</b>	1	-22	M22 x 1.5	14	12	-08	81.1	3.19	49.6	1.95	10.0	0.39	20.7	0.81	27	1.06	0.118	0.260
<b>20541-22-06TZ</b>	1	-22	M22 x 1.5	14	10	-06	72.0	2.84	42.0	1.65	7.0	0.28	18.0	0.71	27	1.06	0.105	0.231
<b>20541-24-06TZ</b>	1	-24	M24 x 1.5	16	10	-06	72.3	2.85	42.3	1.67	7.0	0.28	18.4	0.72	30	1.18	0.114	0.251
<b>20541-24-08TZ</b>	1	-24	M24 x 1.5	16	12	-08	78.8	3.10	47.3	1.86	10.0	0.39	21.0	0.83	30	1.18	0.142	0.313
<b>20541-30-10TZ</b>	1	-30	M30 x 2	20	16	-10	91.3	3.59	57.3	2.26	12.0	0.47	25.0	0.98	36	1.42	0.250	0.551
<b>20541-30-12TZ</b>	1	-30	M30 x 2	20	19	-12	104.3	4.11	65.8	2.59	15.0	0.59	26.7	1.05	36	1.42	0.248	0.547
<b>20541-36-12TZ</b>	1	-36	M36 x 2	25	19	-12	105.6	4.16	67.1	2.64	15.0	0.59	30.5	1.20	46	1.81	0.400	0.882
<b>20541-36-16WZ</b>	2	-36	M36 x 2	25	25	-16	124.4	4.90	77.4	3.05	21.0	0.83	31.2	1.23	46	1.81	0.450	0.992
<b>20541-42-16TZ</b>	1	-42	M42 x 2	30	25	-16	128.0	5.04	81.0	3.19	21.0	0.83	35.5	1.40	50	1.97	0.540	1.190
<b>20541-52-20TZ</b>	1	-52	M52 x 2	38	31	-20	155.7	6.13	101.7	4.00	27.0	1.06	39.4	1.55	60	2.36	0.813	1.792
<b>20541-52-24TZ</b>	1	-52	M52 x 2	38	38	-24	182.1	7.17	114.1	4.49	32.0	1.26	43.4	1.71	60	2.36	1.284	2.831

1 Denotes Style 1 design

2 Denotes Style 2 wire nut design

# 20591

DIN 24° DKO Heavy Female Swivel - 90° Elbow

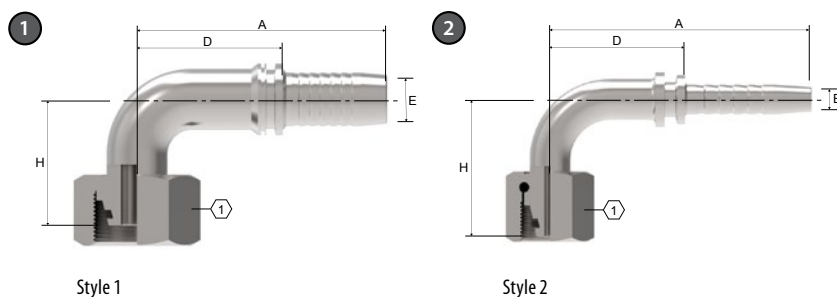

PART	HOSE SIZE INFO						DIMENSIONS								WEIGHT				
	Winner 2pc part #	Ter-minal End	Thread	Tube O.D.	Hose Size	Dash Size	A		D Cut Off Factor		E Ø		H		1		Weight		
STY.				DN		mm	in	mm	in	mm	in	mm	in	mm	in	mm	in	kg	lb
20591-14-04WZ	2	-14	M14 x 1.5	6	6	-04	58.0	2.28	30.0	1.18	4.0	0.16	30.5	1.20	17	0.67	0.045	0.099	
20591-16-04TZ	1	-16	M16 x 1.5	8	6	-04	58.0	2.28	30.0	1.18	4.0	0.16	31.0	1.22	19	0.75	0.040	0.088	
20591-16-05WZ	2	-16	M16 x 1.5	8	8	-05	58.0	2.28	30.0	1.18	5.5	0.22	31.0	1.22	19	0.75	0.050	0.110	
20591-16-06WZ	2	-16	M16 x 1.5	8	10	-06	60.0	2.36	30.0	1.18	7.0	0.28	31.0	1.22	19	0.75	0.059	0.130	
20591-18-04TZ	1	-18	M18 x 1.5	10	6	-04	58.0	2.28	30.0	1.18	4.0	0.16	32.0	1.26	22	0.87	0.065	0.144	
20591-18-05TZ	1	-18	M18 x 1.5	10	8	-05	61.0	2.40	33.0	1.30	5.5	0.22	33.5	1.32	22	0.87	0.050	0.110	
20591-18-06TZ	1	-18	M18 x 1.5	10	10	-06	67.0	2.64	37.0	1.46	7.0	0.28	35.0	1.38	22	0.87	0.078	0.172	
20591-20-05TZ	1	-20	M20 x 1.5	12	8	-05	61.0	2.40	33.0	1.30	5.5	0.22	34.0	1.34	24	0.94	0.080	0.176	
20591-20-06TZ	1	-20	M20 x 1.5	12	10	-06	64.5	2.54	34.5	1.36	7.0	0.28	35.5	1.40	24	0.94	0.094	0.207	
20591-20-08WZ	2	-20	M20 x 1.5	12	12	-08	69.5	2.74	38.0	1.50	10.0	0.39	38.0	1.50	24	0.94	0.098	0.216	
20591-22-06TZ	1	-22	M22 x 1.5	14	10	-06	64.5	2.54	34.5	1.36	7.0	0.28	36.0	1.42	27	1.06	0.114	0.251	
20591-22-08TZ	1	-22	M22 x 1.5	14	12	-08	73.5	2.89	42.0	1.65	10.0	0.39	42.5	1.67	27	1.06	0.136	0.300	
20591-24-06TZ	1	-24	M24 x 1.5	16	10	-06	64.5	2.54	34.5	1.36	7.0	0.28	36.5	1.44	30	1.18	0.125	0.276	
20591-24-08TZ	1	-24	M24 x 1.5	16	12	-08	71.0	2.80	39.5	1.56	10.0	0.39	43.0	1.69	30	1.18	0.136	0.300	
20591-30-08TZ	1	-30	M30 x 2	20	12	-08	76.0	2.99	44.5	1.75	10.0	0.39	46.0	1.81	36	1.42	0.196	0.432	
20591-30-10TZ	1	-30	M30 x 2	20	16	-10	83.0	3.27	49.0	1.93	12.0	0.47	49.5	1.95	36	1.42	0.265	0.584	
20591-30-12TZ	1	-30	M30 x 2	20	19	-12	94.3	3.71	55.8	2.20	15.0	0.59	54.5	2.15	36	1.42	0.265	0.584	
20591-36-12TZ	1	-36	M36 x 2	25	19	-12	94.5	3.72	56.0	2.20	15.0	0.59	59.0	2.32	46	1.81	0.482	1.063	
20591-36-16WZ	2	-36	M36 x 2	25	25	-16	112.5	4.43	65.5	2.58	21.0	0.83	63.5	2.50	46	1.81	0.500	1.102	
20591-42-16TZ	1	-42	M42 x 2	30	25	-16	118.0	4.65	71.0	2.80	21.0	0.83	70.0	2.76	50	1.97	0.610	1.345	
20591-52-20TZ	1	-52	M52 x 2	38	31	-20	147.0	5.79	93.0	3.66	27.0	1.06	86.5	3.41	60	2.36	0.945	2.083	
20591-52-24TZ	1	-52	M52 x 2	38	38	-24	177.4	6.98	109.4	4.31	32.0	1.26	100.0	3.94	60	2.36	1.630	3.594	

1 Denotes Style 1 design

2 Denotes Style 2 wire nut design

# Winner

## Braided and spiral – standard fittings

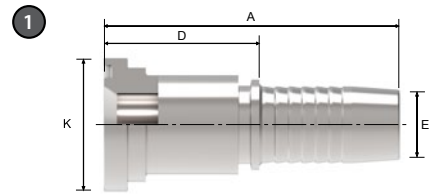

# 87311

SAE CODE 61 Flange

PART	HOSE SIZE INFO					DIMENSIONS						WEIGHT	
	Winner 2pc part #	Terminal End	K		Hose Size		A		D Cut Off Factor		E Ø		Weight
		mm	in	DN	Dash Size	mm	in	mm	in	mm	in	kg	lb
<b>87311-08-08Z</b>	-08	30.2	1.19	12	-08	77.5	3.05	46.0	1.81	10.0	0.39	0.11	0.24
<b>87311-12-08Z</b>	-12	38.1	1.50	12	-08	78.5	3.09	47.0	1.85	10.0	0.39	0.165	0.364
<b>87311-12-10Z</b>	-12	38.1	1.50	16	-10	81.5	3.21	47.5	1.87	12.0	0.47	0.20	0.44
<b>87311-12-12Z</b>	-12	38.1	1.50	19	-12	86.5	3.41	48.0	1.89	15.0	0.59	0.21	0.46
<b>87311-12-16Z</b>	-12	38.1	1.50	25	-16	96.0	3.78	49.0	1.93	21.0	0.83	0.26	0.58
<b>87311-16-12Z</b>	-16	44.4	1.75	19	-12	89.5	3.52	51.0	2.01	15.0	0.59	0.24	0.52
<b>87311-16-16Z</b>	-16	44.4	1.75	25	-16	99.0	3.90	52.0	2.05	21.0	0.83	0.30	0.65
<b>87311-16-20Z</b>	-16	44.4	1.75	31	-20	107.0	4.21	53.0	2.09	26.0	1.02	0.37	0.81
<b>87311-20-16Z</b>	-20	50.8	2.00	25	-16	104.0	4.09	57.0	2.24	21.0	0.83	0.35	0.78
<b>87311-20-20Z</b>	-20	50.8	2.00	31	-20	112.0	4.41	58.0	2.28	27.0	1.06	0.44	0.97
<b>87311-20-24Z</b>	-20	50.8	2.00	38	-24	129.0	5.08	61.0	2.40	32.0	1.26	0.51	1.11
<b>87311-24-20Z</b>	-24	60.3	2.37	31	-20	122.0	4.80	68.0	2.68	27.0	1.06	0.60	1.32
<b>87311-24-24Z</b>	-24	60.3	2.37	38	-24	136.0	5.35	68.0	2.68	32.0	1.26	0.68	1.50
<b>87311-32-20Z</b>	-32	71.4	2.81	31	-20	124.0	4.88	70.0	2.76	27.0	1.06	0.65	1.43
<b>87311-32-24Z</b>	-32	71.4	2.81	38	-24	138.0	5.43	70.0	2.76	32.0	1.26	0.81	1.78
<b>87311-32-32Z</b>	-32	71.4	2.81	51	-32	142.0	5.59	70.0	2.76	43.0	1.69	1.04	2.29

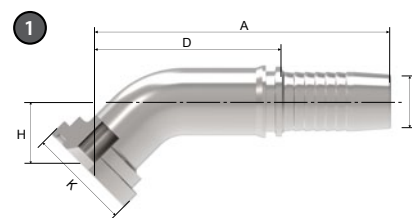

# 87341

SAE CODE 61 Flange - 45° Elbow

PART	HOSE SIZE INFO					DIMENSIONS								WEIGHT	
	Winner 2pc part #	Terminal End	K		Hose Size		A		D Cut Off Factor		E Ø		H		Weight
		mm	in	DN	Dash Size	mm	in	mm	in	mm	in	mm	in	kg	lb
<b>87341-08-08Z</b>	-08	30.2	1.19	12	-08	89.7	3.53	58.2	2.29	10.0	0.39	23.3	0.92	0.11	0.24
<b>87341-12-08Z</b>	-12	38.1	1.50	12	-08	90.4	3.56	58.9	2.32	10.0	0.39	24.0	0.94	0.152	0.0335
<b>87341-12-12Z</b>	-12	38.1	1.50	19	-12	114.8	4.52	76.3	3.00	15.0	0.59	28.9	1.14	0.27	0.58
<b>87341-12-16Z</b>	-12	38.1	1.50	25	-16	131.7	5.19	84.7	3.33	21.0	0.83	29.7	1.17	0.33	0.73
<b>87341-16-12Z</b>	-16	44.4	1.75	19	-12	114.8	4.52	76.3	3.00	15.0	0.59	28.9	1.14	0.30	0.65
<b>87341-16-16Z</b>	-16	44.4	1.75	25	-16	130.9	5.15	83.9	3.30	21.0	0.83	29.7	1.17	0.36	0.79
<b>87341-16-20Z</b>	-16	44.4	1.75	31	-20	148.5	5.85	94.5	3.72	27.0	1.06	33.8	1.33	0.47	1.03
<b>87341-20-16Z</b>	-20	50.8	2.00	25	-16	132.2	5.20	85.2	3.35	21.0	0.83	29.7	1.17	0.40	0.87
<b>87341-20-20Z</b>	-20	50.8	2.00	31	-20	148.5	5.85	94.5	3.72	27.0	1.06	33.8	1.33	0.51	1.12
<b>87341-20-24Z</b>	-20	50.8	2.00	38	-24	171.0	6.73	103.0	4.06	32.0	1.26	33.8	1.33	0.66	1.46
<b>87341-24-20Z</b>	-24	60.3	2.37	31	-20	149.9	5.90	95.9	3.78	27.0	1.06	35.2	1.39	0.58	1.28
<b>87341-24-24Z</b>	-24	60.3	2.37	38	-24	177.9	7.00	109.9	4.33	32.0	1.26	39.1	1.54	0.95	2.09
<b>87341-24-32Z</b>	-24	60.3	2.37	51	-32	200.6	7.90	128.6	5.06	43.0	1.69	41.3	1.63	1.22	2.69
<b>87341-32-24Z</b>	-32	71.4	2.81	38	-24	177.9	7.00	109.9	4.33	32.0	1.26	39.1	1.54	1.05	2.31
<b>87341-32-32Z</b>	-32	71.4	2.81	51	-32	201.3	7.93	129.3	5.09	43.0	1.69	46.3	1.82	1.54	3.39

# Winner

## Braided and spiral – standard fittings

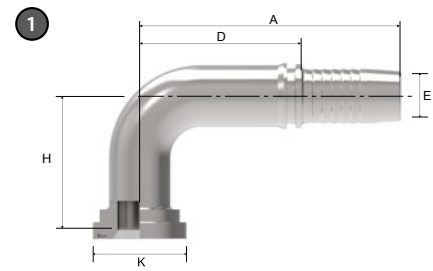

# 87391

SAE CODE 61 Flange - 90° Elbow

PART	HOSE SIZE INFO					DIMENSIONS								WEIGHT	
	Winner 2pc part #	Terminal End	K		Hose Size	A		D Cut Off Factor		E Ø		H		Weight	
		mm	in	DN	Dash Size	mm	in	mm	in	mm	in	mm	in	kg	lb
<b>87391-08-08Z</b>	-08	30.2	1.19	12	-08	72.5	2.85	41.0	1.61	10.0	0.39	47.0	1.85	0.122	0.268
<b>87391-12-08Z</b>	-12	38.1	1.50	12	-08	72.5	2.85	41.0	1.61	10.0	0.39	48.0	1.89	0.164	0.361
<b>87391-12-10Z</b>	-12	38.1	1.50	16	-10	90.0	3.54	56.0	2.20	12.0	0.47	52.5	2.07	0.220	0.484
<b>87391-12-12Z</b>	-12	38.1	1.50	19	-12	104.7	4.12	66.2	2.61	15.0	0.59	62.0	2.44	0.320	0.704
<b>87391-12-16Z</b>	-12	38.1	1.50	25	-16	123.7	4.87	76.7	3.02	21.0	0.83	67.5	2.66	0.384	0.845
<b>87391-16-12Z</b>	-16	44.4	1.75	19	-12	104.0	4.09	65.5	2.58	15.0	0.59	62.0	2.44	0.370	0.814
<b>87391-16-16Z</b>	-16	44.4	1.75	25	-16	123.7	4.87	76.7	3.02	21.0	0.83	67.5	2.66	0.425	0.935
<b>87391-16-20Z</b>	-16	44.4	1.75	31	-20	145.5	5.73	91.5	3.60	27.0	1.06	78.5	3.09	0.592	1.302
<b>87391-20-12Z</b>	-20	50.8	2.00	19	-12	104.7	4.12	66.2	2.61	15.0	0.59	62.0	2.44	0.388	0.853
<b>87391-20-16Z</b>	-20	50.8	2.00	25	-16	123.7	4.87	76.7	3.02	21.0	0.83	67.5	2.66	0.460	1.012
<b>87391-20-20Z</b>	-20	50.8	2.00	31	-20	145.5	5.73	91.5	3.60	27.0	1.06	78.5	3.09	0.636	1.399
<b>87391-20-24Z</b>	-20	50.8	2.00	38	-24	175.0	6.89	107.0	4.21	32.0	1.26	78.5	3.09	0.902	1.984
<b>87391-24-16Z</b>	-24	60.3	2.37	25	-16	123.7	4.87	76.7	3.02	21.0	0.83	69.5	2.74	0.538	1.184
<b>87391-24-20Z</b>	-24	60.3	2.37	31	-20	145.5	5.73	91.5	3.60	27.0	1.06	80.5	3.17	0.700	1.540
<b>87391-24-24Z</b>	-24	60.3	2.37	38	-24	177.4	6.98	109.4	4.31	32.0	1.26	94.0	3.70	1.212	2.666
<b>87391-32-24Z</b>	-32	71.4	2.81	38	-24	177.4	6.98	109.4	4.31	32.0	1.26	94.0	3.70	1.344	2.957
<b>87391-32-32Z</b>	-32	71.4	2.81	51	-32	203.8	8.02	131.8	5.19	43.0	1.69	114.3	4.50	2.200	4.840

# 16711

JIC 37° Male

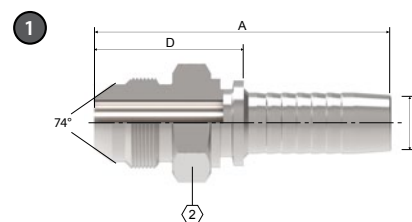

PART	HOSE SIZE INFO				DIMENSIONS								WEIGHT	
	Winner 2pc part #	Terminal End	Thread	Hose Size	A		D Cut Off Factor		E Ø		2		Weight	
			DN	Dash Size	mm	in	mm	in	mm	in	mm	in	kg	lb
<b>16711-04-04Z</b>	-04	7/16"-20	6	-04	54.5	2.15	26.5	1.04	4.0	0.16	12	0.47	0.024	0.053
<b>16711-04-08Z</b>	-04	7/16"-20	12	-08	58.5	2.30	27.0	1.06	10.0	0.39	19	0.75	0.045	0.099
<b>16711-05-04Z</b>	-05	1/2"-20	6	-04	54.5	2.15	26.5	1.04	4.0	0.16	14	0.55	0.024	0.053
<b>16711-05-05Z</b>	-05	1/2"-20	8	-05	54.5	2.15	26.5	1.04	5.5	0.22	14	0.55	0.025	0.055
<b>16711-05-06Z</b>	-05	1/2"-20	10	-06	56.5	2.22	26.5	1.04	7.0	0.28	17	0.67	0.032	0.071
<b>16711-06-04Z</b>	-06	9/16"-18	6	-04	54.5	2.15	26.5	1.04	4.0	0.16	17	0.67	0.030	0.066
<b>16711-06-05Z</b>	-06	9/16"-18	8	-05	54.5	2.15	26.5	1.04	5.5	0.22	17	0.67	0.030	0.066
<b>16711-06-06Z</b>	-06	9/16"-18	10	-06	56.5	2.22	26.5	1.04	7.0	0.28	17	0.67	0.034	0.075
<b>16711-06-08Z</b>	-06	9/16"-18	12	-08	58.5	2.30	27.0	1.06	10.0	0.39	19	0.75	0.046	0.101
<b>16711-08-04Z</b>	-08	3/4"-16	6	-04	59.5	2.34	31.5	1.24	4.0	0.16	19	0.75	0.045	0.099
<b>16711-08-06Z</b>	-08	3/4"-16	10	-06	61.5	2.42	31.5	1.24	7.0	0.28	22	0.87	0.062	0.137
<b>16711-08-08Z</b>	-08	3/4"-16	12	-08	63.5	2.50	32.0	1.26	9.9	0.39	22	0.87	0.064	0.141
<b>16711-10-06Z</b>	-10	7/8"-14	10	-06	63.5	2.50	33.5	1.32	7.0	0.28	24	0.94	0.070	0.154
<b>16711-10-08Z</b>	-10	7/8"-14	12	-08	65.5	2.58	34.0	1.34	10.0	0.39	24	0.94	0.084	0.185
<b>16711-10-10Z</b>	-10	7/8"-14	16	-10	69.0	2.72	35.0	1.38	12.0	0.47	24	0.94	0.092	0.203
<b>16711-10-12Z</b>	-10	7/8"-14	19	-12	75.5	2.97	37.0	1.46	15.0	0.59	27	1.06	0.130	0.287
<b>16711-12-08Z</b>	-12	1 1/16"-12	12	-08	70.0	2.76	38.5	1.52	10.0	0.39	30	1.18	0.116	0.256
<b>16711-12-10Z</b>	-12	1 1/16"-12	16	-10	73.5	2.89	39.5	1.56	12.0	0.47	30	1.18	0.120	0.265
<b>16711-12-12Z</b>	-12	1 1/16"-12	19	-12	78.5	3.09	40.0	1.57	15.0	0.59	30	1.18	0.140	0.309
<b>16711-12-16Z</b>	-12	1 1/16"-12	25	-16	89.5	3.52	42.5	1.67	21.0	0.83	32	1.26	0.198	0.437
<b>16711-14-12Z</b>	-14	1 3/16"-12	19	-12	79.0	3.11	40.5	1.59	15.0	0.59	32	1.26	0.162	0.357
<b>16711-16-12Z</b>	-16	1 5/16"-12	19	-12	81.5	3.21	43.0	1.69	15.0	0.59	36	1.42	0.190	0.419
<b>16711-16-16Z</b>	-16	1 5/16"-12	25	-16	90.5	3.56	43.5	1.71	21.0	0.83	36	1.42	0.206	0.454
<b>16711-20-16Z</b>	-20	1 5/8"-12	25	-16	94.0	3.70	47.0	1.85	21.0	0.83	46	1.81	0.336	0.741
<b>16711-20-20Z</b>	-20	1 5/8"-12	31	-20	101.0	3.98	47.0	1.85	27.0	1.06	46	1.81	0.370	0.816
<b>16711-24-20Z</b>	-24	1 7/8"-12	31	-20	107.0	4.21	53.0	2.09	27.0	1.06	50	1.97	0.495	1.091
<b>16711-24-24Z</b>	-24	1 7/8"-12	38	-24	121.0	4.76	53.0	2.09	32.0	1.26	50	1.97	0.542	1.195
<b>16711-32-32Z</b>	-32	2 1/2"-12	51	-32	134.0	5.28	62.0	2.44	43.0	1.69	65	2.56	1.060	2.337



# Winner

## Braided and spiral – standard fittings

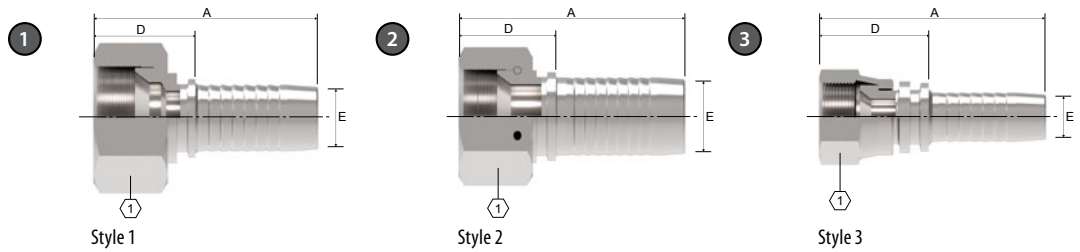

# 26711

JIC 37° Female Swivel

PART	HOSE SIZE INFO					DIMENSIONS							WEIGHT		
	Winner 2pc part #	Terminal End	Thread	Hose Size		A		D Cut Off Factor		E Ø		1		Weight	
	STY.			DN	Dash Size	mm	in	mm	in	mm	in	mm	in	kg	lb
<b>26711-04-03Z</b>	1	-04	7/16"-20	5	-03	35.5	1.40	14.0	0.55	3.0	0.12	14	0.55	0.015	0.033
<b>26711-04-04Z</b>	3	-04	7/16"-20	6	-04	43.0	1.69	15.0	0.59	4.0	0.16	14	0.55	0.020	0.044
<b>26711-04-05Z</b>	3	-04	7/16"-20	8	-05	43.0	1.69	15.0	0.59	5.5	0.22	14	0.55	0.022	0.049
<b>26711-04-06Z</b>	3	-04	7/16"-20	10	-06	44.5	1.75	14.5	0.57	7.0	0.28	14	0.55	0.028	0.062
<b>26711-05-04Z</b>	3	-05	1/2"-20	6	-04	43.5	1.71	15.5	0.61	4.0	0.16	17	0.67	0.026	0.057
<b>26711-05-05Z</b>	3	-05	1/2"-20	8	-05	43.5	1.71	15.5	0.61	5.5	0.22	17	0.67	0.025	0.055
<b>26711-05-06Z</b>	1	-05	1/2"-20	10	-06	45.5	1.79	15.5	0.61	7.0	0.28	17	0.67	0.032	0.071
<b>26711-06-04Z</b>	3	-06	9/16"-18	6	-04	43.5	1.71	15.5	0.61	4.0	0.16	19	0.75	0.032	0.071
<b>26711-06-05Z</b>	3	-06	9/16"-18	8	-05	43.5	1.71	15.5	0.61	5.5	0.22	19	0.75	0.035	0.077
<b>26711-06-06Z</b>	3	-06	9/16"-18	10	-06	45.5	1.79	15.5	0.61	7.0	0.28	19	0.75	0.037	0.082
<b>26711-06-08Z</b>	1	-06	9/16"-18	12	-08	47.5	1.87	16.0	0.63	10.0	0.39	19	0.75	0.046	0.101
<b>26711-08-04TZ</b>	1	-08	3/4"-16	6	-04	43.5	1.71	15.5	0.61	4.0	0.16	24	0.94	0.054	0.119
<b>26711-08-06Z</b>	3	-08	3/4"-16	10	-06	47.5	1.87	17.5	0.69	7.0	0.28	22	0.87	0.054	0.119
<b>26711-08-08Z</b>	3	-08	3/4"-16	12	-08	50.0	1.97	18.5	0.73	9.9	0.39	22	0.87	0.060	0.132
<b>26711-08-10Z</b>	3	-08	3/4"-16	16	-10	52.0	2.05	18.0	0.71	12.0	0.47	22	0.87	0.078	0.172
<b>26711-08-12Z</b>	3	-08	3/4"-16	19	-12	58.0	2.28	19.5	0.77	15.0	0.59	22	0.87	0.078	0.172
<b>26711-10-06TZ</b>	3	-10	7/8"-14	10	-06	47.5	1.87	17.5	0.69	7.0	0.28	27	1.06	0.080	0.176
<b>26711-10-08Z</b>	3	-10	7/8"-14	12	-08	50.5	1.99	19.0	0.75	10.0	0.39	27	1.06	0.090	0.198
<b>26711-10-10Z</b>	3	-10	7/8"-14	16	-10	53.5	2.11	19.5	0.77	12.0	0.47	27	1.06	0.100	0.220
<b>26711-10-12Z</b>	3	-10	7/8"-14	19	-12	58.5	2.30	20.0	0.79	15.0	0.59	27	1.06	0.110	0.243
<b>26711-12-08TZ</b>	1	-12	1 1/16"-12	12	-08	51.0	2.01	19.5	0.77	10.0	0.39	32	1.26	0.128	0.282
<b>26711-12-10Z</b>	3	-12	1 1/16"-12	16	-10	55.0	2.17	21.0	0.83	12.0	0.47	32	1.26	0.120	0.265
<b>26711-12-12Z</b>	3	-12	1 1/16"-12	19	-12	60.0	2.36	21.5	0.85	15.0	0.59	32	1.26	0.130	0.287
<b>26711-12-16Z</b>	1	-12	1 1/16"-12	25	-16	70.0	2.76	23.0	0.91	21.0	0.83	32	1.26	0.172	0.379
<b>26711-14-12Z</b>	3	-14	1 3/16"-12	19	-12	60.0	2.36	21.5	0.85	15.0	0.59	36	1.42	0.154	0.340
<b>26711-14-16Z</b>	1	-14	1 3/16"-12	25	-16	69.5	2.74	22.5	0.89	21.0	0.83	36	1.42	0.170	0.375
<b>26711-16-12TZ</b>	1	-16	1 5/16"-12	19	-12	57.0	2.24	18.5	0.73	15.0	0.59	41	1.61	0.215	0.474
<b>26711-16-16Z</b>	3	-16	1 5/16"-12	25	-16	70.0	2.76	23.0	0.91	21.0	0.83	41	1.61	0.210	0.463
<b>26711-16-20Z</b>	1	-16	1 5/16"-12	31	-20	78.0	3.07	24.0	0.94	27.0	1.06	41	1.61	0.306	0.675
<b>26711-20-16TZ</b>	1	-20	1 5/8"-12	25	-16	70.0	2.76	23.0	0.91	21.0	0.83	50	1.97	0.340	0.750
<b>26711-20-20WZ</b>	2	-20	1 5/8"-12	31	-20	78.5	3.09	24.5	0.96	27.0	1.06	50	1.97	0.400	0.882
<b>26711-24-20TZ</b>	1	-24	1 7/8"-12	31	-20	79.0	3.11	25.0	0.98	27.0	1.06	60	2.36	0.490	1.080
<b>26711-24-24WZ</b>	2	-24	1 7/8"-12	38	-24	94.5	3.72	26.5	1.04	32.0	1.26	60	2.36	0.568	1.252
<b>26711-32-24TZ</b>	1	-32	2 1/2"-12	38	-24	95.0	3.74	27.0	1.06	32.0	1.26	75	2.95	0.920	2.028
<b>26711-32-32TZ</b>	1	-32	2 1/2"-12	51	-32	99.0	3.90	27.0	1.06	43.0	1.69	75	2.95	1.072	2.363

1 Denotes Style 1 design    2 Denotes Style 2 wire nut design    3 Denotes Style 3 crimp nut design

# 26711D

JIC 37° Female Swivel

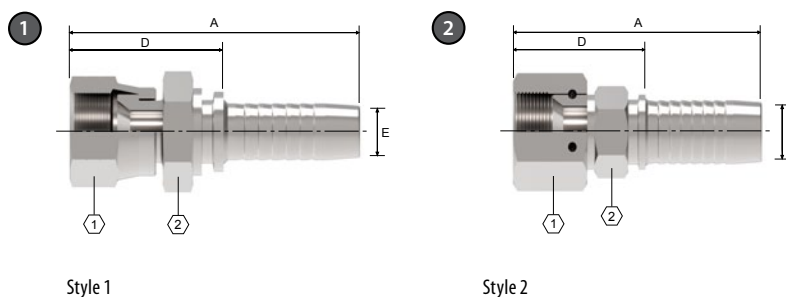

PART	STY.	HOSE SIZE INFO				DIMENSIONS							WEIGHT			
		Ter- minal End	Thread	Hose Size		A		D Cut Off Factor		E Ø		1	2	Weight		
Winner 2pc part #				DN	Dash Size	mm	in	mm	in	mm	in	mm	mm	mm	kg	lb
<b>26711D-04-04Z</b>	1	-04	7/16"-20	6	-04	57.0	2.24	29.0	1.14	4.0	0.16	14	14	0.040	0.088	
<b>26711D-04-04SMZ</b>	1	-04	7/16"-20	6	-04	57.0	2.24	29.0	1.14	4.0	0.16	14	12	0.040	0.088	
<b>26711D-06-04Z</b>	1	-06	9/16"-18	6	-04	59.0	2.32	31.0	1.22	4.0	0.16	19	19	0.044	0.097	
<b>26711D-06-04SMZ</b>	1	-06	9/16"-18	6	-04	59.0	2.32	31.0	1.22	4.0	0.16	19	14	0.045	0.099	
<b>26711D-06-05Z</b>	1	-06	9/16"-18	8	-05	59.0	2.32	31.0	1.22	5.5	0.22	19	19	0.046	0.101	
<b>26711D-06-06Z</b>	1	-06	9/16"-18	10	-06	61.0	2.40	31.0	1.22	7.0	0.28	19	19	0.045	0.099	
<b>26711D-06-06SMZ</b>	1	-06	9/16"-18	10	-06	61.0	2.40	31.0	1.22	7.0	0.28	19	17	0.045	0.099	
<b>26711D-08-04Z</b>	1	-08	3/4"-16	6	-04	53.0	2.09	25.0	0.98	4.0	0.16	22	24	0.075	0.165	
<b>26711D-08-06Z</b>	1	-08	3/4"-16	10	-06	66.0	2.60	36.0	1.42	7.0	0.28	22	22	0.081	0.179	
<b>26711D-08-06SMZ</b>	1	-08	3/4"-16	10	-06	66.0	2.60	36.0	1.42	7.0	0.28	22	19	0.085	0.187	
<b>26711D-08-08Z</b>	1	-08	3/4"-16	12	-08	67.0	2.64	35.5	1.40	9.9	0.39	22	22	0.080	0.176	
<b>26711D-08-08SMZ</b>	1	-08	3/4"-16	12	-08	67.0	2.64	23.5	0.93	9.9	0.39	22	19	0.085	0.187	
<b>26711D-10-08Z</b>	1	-10	7/8"-14	12	-08	57.5	2.26	26.0	1.02	10.0	0.39	27	27	0.108	0.238	
<b>26711D-10-08SMZ</b>	1	-10	7/8"-14	12	-08	57.5	2.26	26.0	1.02	10.0	0.39	27	22	0.104	0.229	
<b>26711D-10-10Z</b>	1	-10	7/8"-14	16	-10	61.0	2.40	27.0	1.06	12.0	0.47	27	27	0.120	0.265	
<b>26711D-10-10SMZ</b>	1	-10	7/8"-14	16	-10	61.0	2.40	27.0	1.06	12.0	0.47	27	22	0.104	0.229	
<b>26711D-12-08SMZ</b>	1	-12	1 1/16"-12	12	-08	61.0	2.40	29.5	1.16	10.0	0.39	32	27	0.166	0.366	
<b>26711D-12-10Z</b>	1	-12	1 1/16"-12	16	-10	65.0	2.56	31.0	1.22	12.0	0.47	32	32	0.180	0.397	
<b>26711D-12-12Z</b>	1	-12	1 1/16"-12	19	-12	70.0	2.76	31.5	1.24	15.0	0.59	32	32	0.188	0.414	
<b>26711D-12-12SMZ</b>	1	-12	1 1/16"-12	19	-12	70.0	2.76	31.5	1.24	15.0	0.59	32	27	0.166	0.366	
<b>26711D-16-16Z</b>	1	-16	1 5/16"-12	25	-16	81.5	3.21	34.5	1.36	21.0	0.83	41	41	0.320	0.705	
<b>26711D-16-16SMWZ</b>	2	-16	1 5/16"-12	25	-16	84.5	3.33	37.5	1.48	21.0	0.83	41	32	0.312	0.688	
<b>26711D-20-20SMWZ</b>	2	-20	1 5/8"-12	31	-20	95.0	3.74	41.0	1.61	27.0	1.06	50	41	0.502	1.107	
<b>26711D-32-32SMWZ</b>	2	-32	2 1/2"-12	51	-32	117.0	4.61	45.0	1.77	43.0	1.69	75	65	1.380	3.042	
<b>26711D-24-24SMWZ</b>	2	-24	1 7/8"-12	38	-24	110.0	4.33	42.0	1.65	32.0	1.26	60	46	0.665	1.466	

1 Denotes Style 1 design

2 Denotes Style 2 wire nut design

# Winner

## Braided and spiral – standard fittings

# 26741

JIC 37° Female Swivel - 45° Elbow

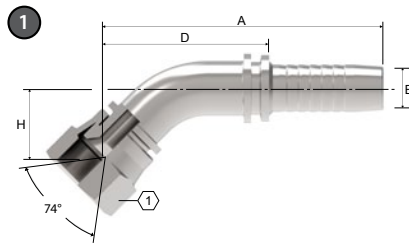

Style 1

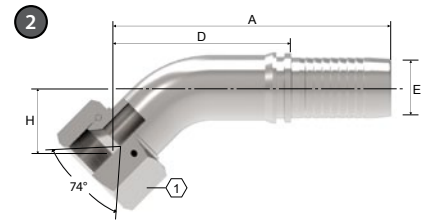

Style 2

PART	HOSE SIZE INFO					DIMENSIONS										WEIGHT	
	Winner 2pc part #	Terminal End	Thread	Hose Size	Dash Size	A		D Cut Off Factor		E Ø		H		1		Weight	
	STY.			DN		mm	in	mm	in	mm	in	mm	in	mm	in	kg	lb
<b>26741-04-03Z</b>	1	-04	7/16"-20	5	-03	54.0	2.13	32.5	1.28	3.0	0.12	12.1	0.48	14	0.55	0.029	0.064
<b>26741-04-04Z</b>	1	-04	7/16"-20	6	-04	63.1	2.48	35.1	1.38	4.0	0.16	13.0	0.51	14	0.55	0.035	0.077
<b>26741-04-06Z</b>	1	-04	7/16"-20	10	-06	65.6	2.58	35.6	1.40	7.0	0.28	13.5	0.53	14	0.55	0.036	0.079
<b>26741-05-04Z</b>	1	-05	1/2"-20	6	-04	63.6	2.50	35.6	1.40	4.0	0.16	13.5	0.53	17	0.67	0.038	0.084
<b>26741-05-05Z</b>	1	-05	1/2"-20	8	-05	65.7	2.59	37.7	1.48	5.5	0.22	14.4	0.57	17	0.67	0.050	0.110
<b>26741-06-04Z</b>	1	-06	9/16"-18	6	-04	63.6	2.50	35.6	1.40	4.0	0.16	13.5	0.53	19	0.75	0.045	0.099
<b>26741-06-05Z</b>	1	-06	9/16"-18	8	-05	65.7	2.59	37.7	1.48	5.5	0.22	14.4	0.57	19	0.75	0.056	0.123
<b>26741-06-06Z</b>	1	-06	9/16"-18	10	-06	68.8	2.71	38.8	1.53	7.0	0.28	14.8	0.58	19	0.75	0.062	0.137
<b>26741-06-08Z</b>	1	-06	9/16"-18	12	-08	70.8	2.79	39.3	1.55	10.0	0.39	14.8	0.58	19	0.75	0.064	0.141
<b>26741-06-10Z</b>	1	-06	9/16"-18	16	-10	75.8	2.98	41.8	1.65	12.0	0.47	14.8	0.58	19	0.75	0.068	0.150
<b>26741-08-06Z</b>	1	-08	3/4"-16	10	-06	70.2	2.76	40.2	1.58	7.0	0.28	16.2	0.64	22	0.87	0.080	0.176
<b>26741-08-08Z</b>	1	-08	3/4"-16	12	-08	76.8	3.02	45.3	1.78	10.0	0.39	19.0	0.75	22	0.87	0.105	0.231
<b>26741-08-10Z</b>	1	-08	3/4"-16	16	-10	87.7	3.45	53.7	2.11	12.0	0.47	21.4	0.84	22	0.87	0.120	0.265
<b>26741-10-06Z</b>	1	-10	7/8"-14	10	-06	71.6	2.82	41.6	1.64	7.0	0.28	17.6	0.69	27	1.06	0.092	0.203
<b>26741-10-08Z</b>	1	-10	7/8"-14	12	-08	78.2	3.08	46.7	1.84	10.0	0.39	20.4	0.80	27	1.06	0.120	0.265
<b>26741-10-10Z</b>	1	-10	7/8"-14	16	-10	88.4	3.48	54.4	2.14	12.0	0.47	22.1	0.87	27	1.06	0.146	0.322
<b>26741-10-12Z</b>	1	-10	7/8"-14	19	-12	98.4	3.87	58.9	2.32	15.0	0.59	22.1	0.87	27	1.06	0.170	0.375
<b>26741-12-08Z</b>	1	-12	1 1/16"-12	12	-08	81.9	3.22	50.4	1.98	10.0	0.39	21.1	0.83	32	1.26	0.140	0.309
<b>26741-12-10Z</b>	1	-12	1 1/16"-12	16	-10	89.1	3.51	55.1	2.17	12.0	0.47	22.8	0.90	32	1.26	0.202	0.445
<b>26741-12-12Z</b>	1	-12	1 1/16"-12	19	-12	97.8	3.85	59.3	2.33	15.0	0.59	24.2	0.95	32	1.26	0.240	0.529
<b>26741-12-16Z</b>	1	-12	1 1/16"-12	25	-16	117.3	4.62	70.3	2.77	21.0	0.83	24.2	0.95	32	1.26	0.278	0.613
<b>26741-14-12Z</b>	1	-14	1 3/16"-12	19	-12	98.6	3.88	60.1	2.37	15.0	0.59	24.2	0.95	36	1.42	0.230	0.507
<b>26741-16-12Z</b>	1	-16	1 5/16"-12	19	-12	99.4	3.91	60.9	2.40	15.0	0.59	25.0	0.98	41	1.61	0.346	0.763
<b>26741-16-16Z</b>	1	-16	1 5/16"-12	25	-16	121.3	4.78	74.3	2.93	21.0	0.83	28.7	1.13	41	1.61	0.400	0.882
<b>26741-20-16WZ</b>	2	-20	1 5/8"-12	25	-16	123.6	4.87	76.6	3.02	21.0	0.83	31.1	1.22	50	1.97	0.536	1.182
<b>26741-20-20WZ</b>	2	-20	1 5/8"-12	31	-20	150.3	5.92	96.3	3.79	27.0	1.06	35.5	1.40	50	1.97	0.650	1.433
<b>26741-24-20WZ</b>	2	-24	1 7/8"-12	31	-20	140.6	5.54	86.6	3.41	27.0	1.06	35.9	1.41	60	2.36	0.780	1.720
<b>26741-24-24WZ</b>	2	-24	1 7/8"-12	38	-24	182.8	7.20	114.8	4.52	32.0	1.26	44.1	1.74	60	2.36	1.122	2.474
<b>26741-32-32WZ</b>	2	-32	2 1/2"-12	51	-32	207.9	8.19	135.9	5.35	43.0	1.69	51.6	2.03	75	2.95	2.076	4.577

1 Denotes Style 1 design

2 Denotes Style 2 wire nut design

# 26791

JIC 37° Female Swivel - 90° Elbow

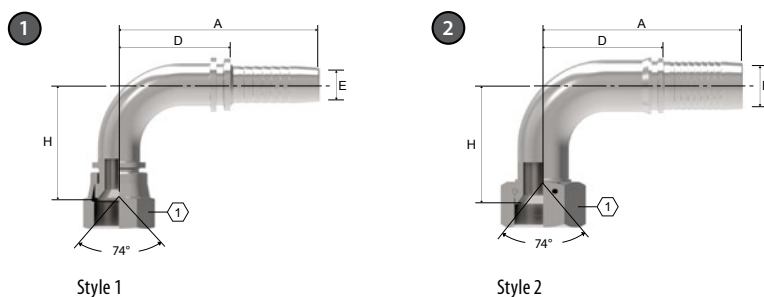

PART	HOSE SIZE INFO					DIMENSIONS										WEIGHT			
	Winner 2pc part #	Ter- minal End	Thread	Hose Size		A		D Cut Off Factor		E Ø		H		①		Weight			
	STY.			DN	Dash Size	mm	in	mm	in	mm	in	mm	in	mm	in	mm	in	kg	lb
<b>26791-04-03Z</b>	①	-04	7/16"-20	5	-03	48.0	1.89	26.5	1.04	3.0	0.12	23.3	0.92	14	0.55	0.024	0.053		
<b>26791-04-04Z</b>	①	-04	7/16"-20	6	-04	58.0	2.28	30.0	1.18	4.0	0.16	26.3	1.04	14	0.55	0.040	0.088		
<b>26791-04-05Z</b>	①	-04	7/16"-20	8	-05	58.0	2.28	30.0	1.18	5.5	0.22	26.3	1.04	14	0.55	0.040	0.088		
<b>26791-04-06Z</b>	①	-04	7/16"-20	10	-06	60.0	2.36	30.0	1.18	7.0	0.28	26.3	1.04	14	0.55	0.040	0.088		
<b>26791-05-04Z</b>	①	-05	1/2"-20	6	-04	58.0	2.28	30.0	1.18	4.0	0.16	27.0	1.06	17	0.67	0.042	0.093		
<b>26791-05-05Z</b>	①	-05	1/2"-20	8	-05	61.0	2.40	33.0	1.30	5.5	0.22	30.0	1.18	17	0.67	0.050	0.110		
<b>26791-05-06Z</b>	①	-05	1/2"-20	10	-06	63.0	2.48	33.0	1.30	7.0	0.28	30.0	1.18	17	0.67	0.055	0.121		
<b>26791-06-04Z</b>	①	-06	9/16"-18	6	-04	58.0	2.28	30.0	1.18	4.0	0.16	27.0	1.06	19	0.75	0.048	0.106		
<b>26791-06-05Z</b>	①	-06	9/16"-18	8	-05	61.0	2.40	33.0	1.30	5.5	0.22	30.5	1.20	19	0.75	0.062	0.137		
<b>26791-06-06Z</b>	①	-06	9/16"-18	10	-06	64.5	2.54	34.5	1.36	7.0	0.28	31.5	1.24	19	0.75	0.070	0.154		
<b>26791-06-08Z</b>	①	-06	9/16"-18	12	-08	69.5	2.74	38.0	1.50	10.0	0.39	31.5	1.24	19	0.75	0.070	0.154		
<b>26791-08-04Z</b>	①	-08	3/4"-16	6	-04	58.0	2.28	30.0	1.18	4.0	0.16	29.0	1.14	22	0.87	0.063	0.139		
<b>26791-08-06Z</b>	①	-08	3/4"-16	10	-06	64.5	2.54	34.5	1.36	7.0	0.28	33.5	1.32	22	0.87	0.088	0.194		
<b>26791-08-08Z</b>	①	-08	3/4"-16	12	-08	71.0	2.80	39.5	1.56	10.0	0.39	40.0	1.57	22	0.87	0.118	0.260		
<b>26791-08-10Z</b>	①	-08	3/4"-16	16	-10	81.5	3.21	45.5	1.79	12.0	0.47	40.0	1.57	22	0.87	0.124	0.273		
<b>26791-08-12Z</b>	①	-08	3/4"-16	19	-12	86.5	3.41	48.0	1.89	15.0	0.59	40.0	1.57	22	0.87	0.134	0.295		
<b>26791-10-06Z</b>	①	-10	7/8"-14	10	-06	66.5	2.62	36.5	1.44	7.0	0.28	34.5	1.36	27	1.06	0.100	0.220		
<b>26791-10-08Z</b>	①	-10	7/8"-14	12	-08	71.0	2.80	39.5	1.56	10.0	0.39	42.0	1.65	27	1.06	0.132	0.291		
<b>26791-10-10Z</b>	①	-10	7/8"-14	16	-10	83.0	3.27	49.0	1.93	12.0	0.47	47.5	1.87	27	1.06	0.190	0.419		
<b>26791-10-12Z</b>	①	-10	7/8"-14	19	-12	92.0	3.62	53.5	2.11	15.0	0.59	47.5	1.87	27	1.06	0.196	0.432		
<b>26791-12-08Z</b>	①	-12	1 1/16"-12	12	-08	75.0	2.95	43.5	1.71	10.0	0.39	43.0	1.69	32	1.26	0.150	0.331		
<b>26791-12-10Z</b>	①	-12	1 1/16"-12	16	-10	83.0	3.27	49.0	1.93	12.0	0.47	49.0	1.93	32	1.26	0.226	0.498		
<b>26791-12-12Z</b>	①	-12	1 1/16"-12	19	-12	93.0	3.66	54.5	2.15	15.0	0.59	53.5	2.11	32	1.26	0.300	0.661		
<b>26791-12-16Z</b>	①	-12	1 1/16"-12	25	-16	112.5	4.43	65.5	2.58	21.0	0.83	53.5	2.11	32	1.26	0.320	0.705		
<b>26791-14-12Z</b>	①	-14	1 3/16"-12	19	-12	93.8	3.69	55.3	2.18	15.0	0.59	53.5	2.11	36	1.42	0.230	0.507		
<b>26791-16-12Z</b>	①	-16	1 5/16"-12	19	-12	93.8	3.69	55.3	2.18	15.0	0.59	53.6	2.11	41	1.61	0.408	0.899		
<b>26791-16-16Z</b>	①	-16	1 5/16"-12	25	-16	118.0	4.65	71.0	2.80	21.0	0.83	66.1	2.60	41	1.61	0.460	1.014		
<b>26791-16-20Z</b>	①	-16	1 5/16"-12	31	-20	135.0	5.31	81.0	3.19	27.0	1.06	66.1	2.60	41	1.61	0.576	1.270		
<b>26791-20-16WZ</b>	②	-20	1 5/8"-12	25	-16	118.0	4.65	71.0	2.80	21.0	0.83	69.5	2.74	50	1.97	0.630	1.389		
<b>26791-20-20WZ</b>	②	-20	1 5/8"-12	31	-20	135.5	5.33	81.5	3.21	27.0	1.06	80.0	3.15	50	1.97	0.784	1.728		
<b>26791-24-20WZ</b>	②	-24	1 7/8"-12	31	-20	135.5	5.33	81.5	3.21	27.0	1.06	81.5	3.21	60	2.36	0.860	1.896		
<b>26791-24-24WZ</b>	②	-24	1 7/8"-12	38	-24	177.4	6.98	109.4	4.31	32.0	1.26	94.0	3.70	60	2.36	1.386	3.056		
<b>26791-32-32WZ</b>	②	-32	2 1/2"-12	51	-32	205.1	8.07	133.1	5.24	43.0	1.69	121.8	4.80	75	2.95	2.600	5.732		

① Denotes Style 1 design

② Denotes Style 2 wire nut design

# Winner

## Braided and spiral – standard fittings

### 14211

ORS Male

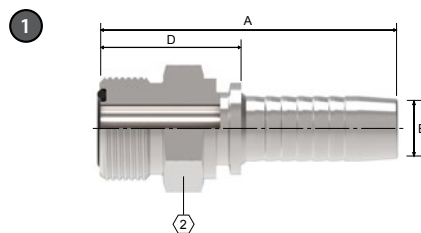

PART	HOSE SIZE INFO				DIMENSIONS								WEIGHT	
	Winner 2pc part #	Terminal End	Thread	Hose Size	A		D Cut Off Factor		E Ø		②		Weight	
			DN	Dash Size	mm	in	mm	in	mm	in	mm	in	kg	lb
<b>14211-04-04Z</b>	-04	9/16" - 18	6	-04	50.5	1.99	22.5	0.89	4.0	0.16	17	0.67	0.030	0.066
<b>14211-06-04Z</b>	-06	11/16" - 16	6	-04	52.0	2.05	24.0	0.94	3.9	0.15	19	0.75	0.038	0.084
<b>14211-06-06Z</b>	-06	11/16" - 16	10	-06	54.0	2.13	24.0	0.94	6.7	0.26	19	0.75	0.040	0.088
<b>14211-08-06Z</b>	-08	13/16" - 16	10	-06	57.5	2.26	27.5	1.08	7.0	0.28	22	0.87	0.060	0.132
<b>14211-08-08Z</b>	-08	13/16" - 16	12	-08	60.0	2.36	28.5	1.12	9.6	0.38	22	0.87	0.070	0.154
<b>14211-10-08Z</b>	-10	1" - 14	12	-08	64.0	2.52	32.5	1.28	10.0	0.39	27	1.06	0.108	0.238
<b>14211-10-10Z</b>	-10	1" - 14	16	-10	67.5	2.66	33.5	1.32	12.0	0.47	27	1.06	0.120	0.264
<b>14211-12-08Z</b>	-12	1 3/16" - 12	12	-08	67.0	2.64	35.5	1.40	10.0	0.39	32	1.26	0.148	0.326
<b>14211-12-10Z</b>	-12	1 3/16" - 12	16	-10	70.0	2.76	36.0	1.42	12.0	0.47	32	1.26	0.164	0.361
<b>14211-12-12Z</b>	-12	1 3/16" - 12	19	-12	75.0	2.95	36.5	1.44	15.0	0.59	32	1.26	0.172	0.378
<b>14211-16-12Z</b>	-16	1 7/16" - 12	19	-12	75.5	2.97	37.0	1.46	14.9	0.59	38	1.50	0.255	0.561
<b>14211-16-16Z</b>	-16	1 7/16" - 12	25	-16	85.5	3.37	38.5	1.52	20.6	0.81	38	1.50	0.248	0.546
<b>14211-20-20Z</b>	-20	1 11/16" - 12	31	-20	95.5	3.76	41.5	1.63	26.0	1.02	46	1.81	0.400	0.880
<b>14211-24-24Z</b>	-24	2" - 12	38	-24	114.5	4.51	46.5	1.83	32.0	1.26	55	2.17	0.624	1.373

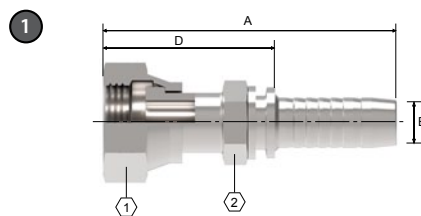

### 24211D

ORS Female Swivel

PART	HOSE SIZE INFO				DIMENSIONS								WEIGHT	
	Winner 2pc part #	Terminal End	Thread	Hose Size	A		D Cut Off Factor		E Ø		①	②	Weight	
			DN		mm	in	mm	in	mm	in	mm	mm	kg	lb
<b>24211D-04-04SMZ</b>	-04	9/16" - 18	6	-04	55.5	2.19	27.5	1.08	4.0	0.16	17	14	0.041	0.090
<b>24211D-06-06SMZ</b>	-06	11/16" - 16	10	-06	60.0	2.36	30.0	1.18	7.0	0.28	22	17	0.060	0.132
<b>24211D-08-08SMZ</b>	-08	13/16" - 16	12	-08	65.0	2.56	33.5	1.32	10.0	0.39	27	19	0.096	0.212
<b>24211D-10-10SMZ</b>	-10	1" - 14	16	-10	74.0	2.91	40.0	1.57	11.5	0.45	30	24	0.140	0.309
<b>24211D-12-12SMZ</b>	-12	1 3/16" - 12	19	-12	83.8	3.30	45.3	1.78	15.0	0.59	36	30	0.195	0.430
<b>24211D-16-16SMZ</b>	-16	1 7/16" - 12	25	-16	95.5	3.76	48.5	1.91	21.0	0.83	41	36	0.260	0.573

Braided and spiral – standard fittings

# 24211

ORS Female Swivel

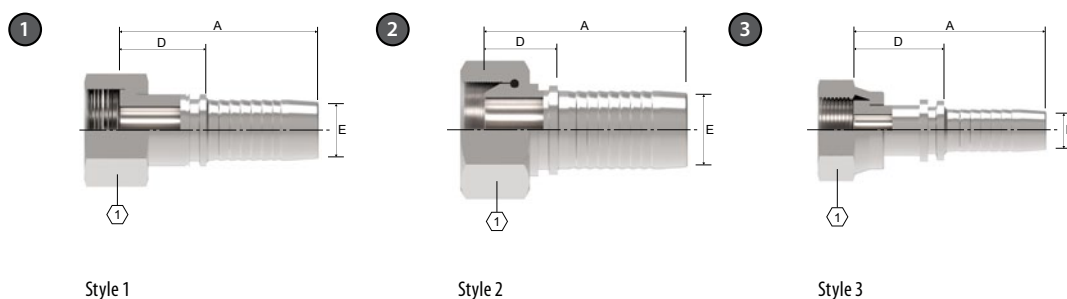

PART		HOSE SIZE INFO				DIMENSIONS							WEIGHT		
Winner 2pc part #		Termi- nal End	Thread	Hose Size		A		D Cut Off Factor		E Ø		①		Weight	
	STY.			DN	Dash Size	mm	in	mm	in	mm	in	mm	in	kg	lb
<b>24211-04-04Z</b>	③	-04	9/16" - 18	6	-04	50.5	1.99	22.5	0.89	4.0	0.16	17	0.67	0.034	0.075
<b>24211-04-06Z 1</b>	③	-04	9/16" - 18	10	-06	52.5	2.07	22.5	0.89	7.0	0.28	17	0.67	0.043	0.095
<b>24211-06-04TZ</b>	①	-06	11/16" - 16	6	-04	51.5	2.03	23.5	0.93	4.0	0.16	22	0.87	0.060	0.132
<b>24211-06-05TZ</b>	①	-06	11/16" - 16	8	-05	51.5	2.03	23.5	0.93	5.5	0.22	22	0.87	0.065	0.143
<b>24211-06-06Z 1</b>	③	-06	11/16" - 16	10	-06	55.5	2.19	25.5	1	7.0	0.28	22	0.87	0.055	0.121
<b>24211-08-06TZ</b>	①	-08	13/16" - 16	10	-06	55.0	2.17	25.0	0.98	7.0	0.28	24	0.94	0.095	0.209
<b>24211-08-08Z 1</b>	③	-08	13/16" - 16	12	-08	59.5	2.34	28.0	1.1	10.0	0.39	27	1.06	0.086	0.19
<b>24211-10-08TZ</b>	①	-10	1" - 14	12	-08	61.0	2.4	29.5	1.16	10.0	0.39	30	1.18	0.130	0.287
<b>24211-10-10Z 1</b>	③	-10	1" - 14	16	-10	67.0	2.64	33.0	1.3	12.0	0.47	30	1.18	0.120	0.265
<b>24211-10-12Z 1</b>	③	-10	1" - 14	19	-12	72.0	2.83	33.5	1.32	15.0	0.59	30	1.18	0.146	0.322
<b>24211-12-08TZ</b>	①	-12	1 3/16" - 12	12	-08	62.0	2.44	30.5	1.2	10.0	0.39	36	1.42	0.185	0.408
<b>24211-12-10TZ</b>	①	-12	1 3/16" - 12	16	-10	65.5	2.58	31.5	1.24	12.0	0.47	36	1.42	0.210	0.463
<b>24211-12-12Z 1</b>	③	-12	1 3/16" - 12	19	-12	73.5	2.89	35.0	1.38	15.0	0.59	36	1.42	0.195	0.43
<b>24211-12-16Z</b>	③	-12	1 3/16" - 12	25	-16	83.0	3.27	36.0	1.42	21.0	0.83	36	1.42	0.236	0.52
<b>24211-16-12TZ</b>	①	-16	1 7/16" - 12	19	-12	73.5	2.89	35.0	1.38	15.0	0.59	41	1.61	0.250	0.551
<b>24211-16-16TZ</b>	①	-16	1 7/16" - 12	25	-16	83.3	3.28	36.3	1.43	21.0	0.83	41	1.61	0.260	0.573
<b>24211-20-16TZ</b>	③	-20	1 11/16" - 12	25	-16	82.5	3.25	35.5	1.40	21.0	0.83	50	1.97	0.385	1.849
<b>24211-20-20WZ</b>	②	-20	1 11/16" - 12	31	-20	96.5	3.8	42.5	1.67	27.0	1.06	50	1.97	0.464	1.023
<b>24211-24-24TZ</b>	①	-24	2" - 12	38	-24	104.0	4.09	36.0	1.42	32.0	1.26	60	2.36	0.660	1.455

- ① Denotes Style 1 design
- ② Denotes Style 2 wire nut design
- ③ Denotes Style 3 crimp nut design

# Winner

## Braided and spiral – standard fittings

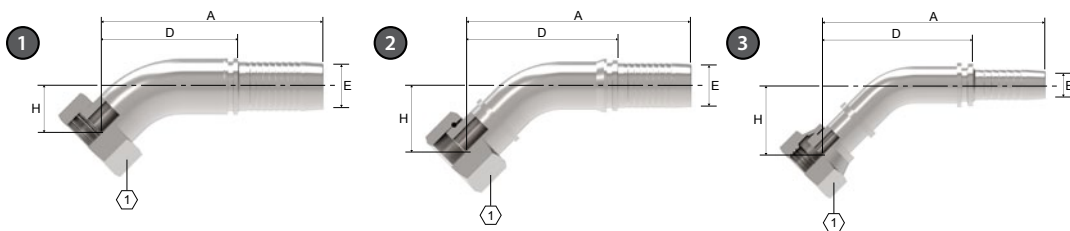

# 24241

ORS Female Swivel - 45° Elbow

Style 1

Style 2

Style 3

PART	HOSE SIZE INFO					DIMENSIONS										WEIGHT		
	Winner 2pc part #	Ter- minal End	Thread	Hose Size	Dash Size	A		D Cut Off Factor		E Ø		H		①		Weight		
STY.			DN		mm	in	mm	in	mm	in	mm	in	mm	in	mm	in	kg	lb
<b>24241-04-04Z</b>	③	-04	9/16" - 18	6	-04	73.5	2.89	45.5	1.79	4.0	0.16	23.4	0.92	17	0.67	0.046	0.101	
<b>24241-04-06Z 1</b>	③	-04	9/16" - 18	10	-06	75.6	2.98	45.6	1.80	7.0	0.28	23.4	0.92	17	0.67	0.056	0.123	
<b>24241-06-04TZ</b>	①	-06	11/16" - 16	6	-04	68.9	2.71	40.9	1.61	4.0	0.16	18.8	0.74	22	0.87	0.070	0.154	
<b>24241-06-06Z</b>	③	-06	11/16" - 16	10	-06	81.3	3.20	51.3	2.02	7.0	0.28	27.1	1.07	22	0.87	0.078	0.172	
<b>24241-06-08Z 1</b>	③	-06	11/16" - 16	12	-08	95.7	3.77	64.2	2.53	10.0	0.39	29.3	1.15	22	0.87	0.132	0.291	
<b>24241-08-06TZ</b>	①	-08	13/16" - 16	10	-06	74.6	2.94	44.6	1.76	7.0	0.28	20.3	0.80	24	0.94	0.110	0.243	
<b>24241-08-08Z</b>	③	-08	13/16" - 16	12	-08	97.2	3.83	65.7	2.59	10.0	0.39	30.7	1.21	27	1.06	0.100	0.220	
<b>24241-10-08TZ</b>	①	-10	1" - 14	12	-08	89.7	3.53	58.2	2.29	10.0	0.39	23.3	0.92	30	1.18	0.162	0.357	
<b>24241-10-10Z</b>	③	-10	1" - 14	16	-10	113.2	4.46	79.2	3.12	12.0	0.47	34.9	1.37	30	1.18	0.210	0.463	
<b>24241-10-12Z 1</b>	③	-10	1" - 14	19	-12	124.4	4.90	85.9	3.38	15.0	0.59	38.5	1.52	30	1.18	0.326	0.719	
<b>24241-12-08TZ</b>	①	-12	1 3/16" - 12	12	-08	89.7	3.53	58.2	2.29	10.0	0.39	23.3	0.92	36	1.42	0.210	0.463	
<b>24241-12-12Z 1</b>	③	-12	1 3/16" - 12	19	-12	125.4	4.94	86.9	3.42	15.0	0.59	39.5	1.56	36	1.42	0.350	0.772	
<b>24241-12-16TZ</b>	①	-12	1 3/16" - 12	25	-16	139.3	5.48	92.3	3.63	21.0	0.83	41.0	1.61	36	1.42	0.524	1.155	
<b>24241-16-16TZ</b>	①	-16	1 7/16" - 12	25	-16	131.1	5.16	84.1	3.31	21.0	0.83	29.7	1.17	41	1.61	0.423	0.933	
<b>24241-20-20WZ</b>	②	-20	1 11/16" - 12	31	-20	165.2	6.50	111.2	4.38	27.0	1.06	49.0	1.93	50	1.97	0.740	1.631	
<b>24241-24-24TZ</b>	①	-24	2" - 12	38	-24	176.5	6.95	108.5	4.27	32.0	1.26	37.7	1.48	60	2.36	1.236	2.725	

- ① Denotes Style 1 design
- ② Denotes Style 2 wire nut design
- ③ Denotes Style 3 crimp nut design

Braided and spiral – standard fittings

# 24291

ORS Female Swivel - 90° Elbow **Style 1**

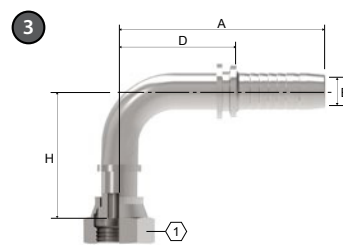
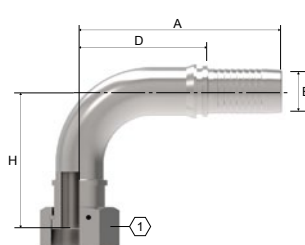
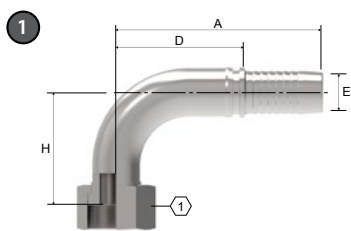

Style 2

Style 3 1

PART	HOSE SIZE INFO					DIMENSIONS										WEIGHT			
	Winner 2pc part #	Ter- minal End	Thread	Hose Size		A		D Cut Off Factor		E Ø		H		1		Weight			
	STY.			DN	Dash Size	mm	in	mm	in	mm	in	mm	in	mm	in	mm	in	kg	lb
<b>24291-04-04Z 2</b>	3	-04	9/16" - 18	6	-04	58.0	2.28	30.0	1.18	4.0	0.16	41.0	1.61	17	0.67	0.052	0.115		
<b>24291-06-04TZ</b>	1	-06	11/16" - 16	6	-04	58.0	2.28	30.0	1.18	4.0	0.16	34.5	1.36	22	0.87	0.065	0.143		
<b>24291-06-06Z</b>	3	-06	11/16" - 16	10	-06	65.3	2.57	35.3	1.39	7.0	0.28	42.5	0.17	22	0.87	0.090	0.198		
<b>24291-06-08Z 1</b>	3	-06	11/16" - 16	10	-06	67.3	2.65	35.8	1.41	10.0	0.39	49.3	1.94	22	0.87	0.098	0.216		
<b>24291-08-06TZ</b>	1	-08	13/16" - 16	10	-06	65.3	2.57	35.3	1.39	7.0	0.28	39.8	1.56	24	0.94	0.120	0.265		
<b>24291-08-08Z</b>	3	-08	13/16" - 16	12	-08	72.5	2.85	41.0	1.61	10.0	0.39	57.5	2.26	27	1.06	0.145	0.320		
<b>24291-10-08TZ</b>	1	-10	1" - 14	12	-08	72.5	2.85	41.0	1.61	10.0	0.39	46.0	1.81	30	1.18	0.174	0.384		
<b>24291-10-10Z</b>	3	-10	1" - 14	16	-10	90.0	3.54	56.0	2.20	12.0	0.47	66.0	2.60	30	1.18	0.235	0.518		
<b>24291-10-12Z 1</b>	3	-10	1" - 14	19	-12	95.5	3.76	57.0	2.24	15.0	0.59	66.0	2.60	30	1.18	0.282	0.622		
<b>24291-12-12Z</b>	3	-12	1 3/16" - 12	19	-12	104.0	4.09	65.5	2.58	15.0	0.59	77.0	3.03	36	1.42	0.390	0.860		
<b>24291-12-08TZ</b>	1	-12	1 3/16" - 12	12	-8	84.0	3.31	52.5	2.07	10.0	0.39	51.5	2.03	36	1.42	0.282	0.622		
<b>24291-16-12TZ</b>	1	-16	1 7/16" - 12	19	-12	104.0	4.09	65.5	2.58	15.0	0.59	63.0	2.48	41	1.61	0.410	0.904		
<b>24291-16-16TZ</b>	1	-16	1 7/16" - 12	25	-16	123.9	4.88	76.9	3.03	21.0	0.83	67.5	2.66	41	1.61	0.504	1.111		
<b>24291-20-16TZ</b>	1	-20	1 11/16" - 12	25	-16	123.7	4.87	76.7	3.02	21.0	0.83	67.5	2.66	50	1.97	0.622	1.371		
<b>24291-20-20WZ</b>	2	-20	1 11/16" - 12	31	-20	147.0	5.79	93.0	3.66	27.0	1.06	100.0	3.94	50	1.97	0.862	1.900		
<b>24291-24-24TZ</b>	1	-24	2" - 12	38	-24	177.4	6.98	109.4	4.31	32.0	1.26	92.0	3.62	60	2.36	1.372	3.025		

- 1 Denotes Style 1 design
- 2 Denotes Style 2 wire nut design
- 3 Denotes Style 3 crimp nut design



# Winner

## Braided and spiral – standard fittings

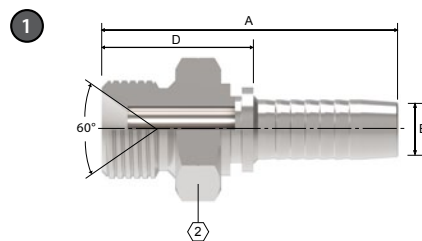

# 12611

BSP 60° Cone Male

PART	HOSE SIZE INFO				DIMENSIONS								WEIGHT	
	Winner 2pc part #	Terminal End	Thread	Hose Size	A		D Cut Off Factor		E Ø		2		Weight	
			DN	Dash Size	mm	in	mm	in	mm	in	mm	in	kg	lb
<b>12611A-02-04Z</b>	-02	G1/8 - 28	6	-04	50.5	1.99	22.5	0.89	4.0	0.16	14	0.55	0.020	0.044
<b>12611A-04-04Z</b>	-04	G1/4" - 19	6	-04	52.5	2.07	24.5	0.96	4.0	0.16	19	0.75	0.030	0.066
<b>12611A-06-04Z</b>	-06	G3/8" - 19	6	-04	56.0	2.20	28.0	1.10	4.0	0.16	22	0.87	0.045	0.099
<b>12611A-06-05Z</b>	-06	G3/8" - 19	8	-05	56.0	2.20	28.0	1.10	5.5	0.22	22	0.87	0.052	0.114
<b>12611A-06-06Z</b>	-06	G3/8" - 19	10	-06	58.0	2.28	28.0	1.10	7.0	0.28	22	0.87	0.050	0.110
<b>12611A-06-08Z</b>	-06	G3/8" - 19	12	-08	60.0	2.36	28.5	1.12	10.0	0.39	22	0.87	0.058	0.128
<b>12611A-08-06Z</b>	-08	G1/2" - 14	10	-06	63.0	2.48	33.0	1.30	7.0	0.28	27	1.06	0.082	0.180
<b>12611A-08-08Z</b>	-08	G1/2" - 14	12	-08	64.5	2.54	33.0	1.30	10.0	0.39	27	1.06	0.090	0.198
<b>12611A-10-10Z</b>	-10	G5/8" - 14	16	-10	69.5	2.74	35.5	1.40	12.0	0.47	30	1.18	0.121	0.266
<b>12611A-12-12Z</b>	-12	G3/4" - 14	19	-12	76.0	2.99	37.5	1.48	15.0	0.59	32	1.26	0.150	0.330
<b>12611A-16-12Z</b>	-16	G1" - 11	19	-12	81.0	3.19	42.5	1.67	15.0	0.59	41	1.61	0.230	0.506
<b>12611A-16-16Z</b>	-16	G1" - 11	25	-16	90.5	3.56	43.5	1.71	21.0	0.83	41	1.61	0.253	0.557
<b>12611A-20-20Z</b>	-20	G1 1/4" - 11	31	-20	100.5	3.94	46.5	1.83	27.0	1.06	50	1.97	0.406	0.893
<b>12611A-24-24Z</b>	-24	G1 1/2" - 11	38	-24	117.0	4.61	49.0	1.93	32.0	1.26	55	2.17	0.554	1.219

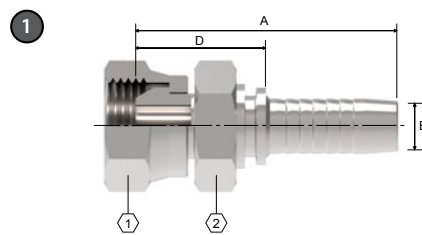

# 22611D

BSP 60° Cone Female Swivel

PART	HOSE SIZE INFO				DIMENSIONS								WEIGHT	
	Winner 2pc part #	Terminal End	Thread	Hose Size	A		D Cut Off Factor		E Ø		1	2	Weight	
			DN	Dash Size	mm	in	mm	in	mm	in	mm	mm	kg	lb
<b>22611D-04-04Z</b>	-04	G1/4" - 19	6	-04	51.5	2.03	23.5	0.93	4.0	0.16	19	19	0.044	0.097
<b>22611D-06-06Z</b>	-06	G3/8" - 19	10	-06	56.5	2.22	26.5	1.04	7.0	0.28	22	22	0.065	0.143
<b>22611D-08-08Z</b>	-08	G1/2" - 14	12	-08	62.5	2.46	31.0	1.22	10.0	0.39	27	27	0.120	0.264
<b>22611D-12-12Z</b>	-12	G3/4" - 14	19	-12	72.0	2.83	33.5	1.32	15.0	0.59	32	32	0.190	0.418
<b>22611D-16-16Z</b>	-16	G1" - 11	25	-16	82.5	3.25	35.5	1.40	21.0	0.83	41	41	0.296	0.651

Braided and spiral – standard fittings

# 22611

BSP 60° Cone Female Swivel

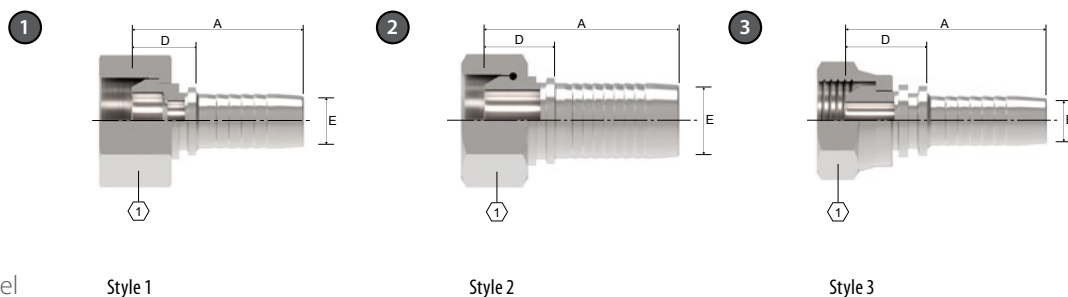

PART	STY.	HOSE SIZE INFO				DIMENSIONS							WEIGHT		
		Ter- minal End	Thread	Hose Size		A		D Cut Off Factor		E Ø		Weight			
Winner 2pc part #				DN	Dash Size	mm	in	mm	in	mm	in	mm	in	kg	lb
<b>22611-04-04Z</b>	3	-04	G1/4" - 19	6	-04	46.0	1.81	18.0	0.71	4.0	0.16	19	0.75	0.032	0.070
<b>22611-04-05Z 1</b>	3	-04	G1/4" - 19	8	-05	46.0	1.81	18.0	0.71	5.0	0.20	19	0.75	0.035	0.077
<b>22611-04-06Z 1</b>	3	-04	G1/4" - 19	10	-06	48.0	1.89	18.0	0.71	7.0	0.28	19	0.75	0.040	0.088
<b>22611-06-04TZ</b>	1	-06	G3/8" - 19	6	-04	45.5	1.79	17.5	0.69	4.0	0.16	22	0.87	0.050	0.110
<b>22611-06-05Z</b>	3	-06	G3/8" - 19	8	-05	47.0	1.85	19.0	0.75	5.5	0.22	22	0.87	0.044	0.097
<b>22611-06-06Z</b>	3	-06	G3/8" - 19	10	-06	49.5	1.95	19.5	0.77	7.0	0.28	22	0.87	0.046	0.101
<b>22611-06-08Z 1</b>	3	-06	G3/8" - 19	12	-08	51.0	2.01	19.5	0.77	10.0	0.39	22	0.87	0.060	0.132
<b>22611-08-06TZ</b>	1	-08	G1/2" - 14	10	-06	48.5	1.91	18.5	0.73	7.0	0.28	27	1.06	0.080	0.176
<b>22611-08-08Z</b>	3	-08	G1/2" - 14	12	-08	53.0	2.09	21.5	0.85	10.0	0.39	27	1.06	0.078	0.172
<b>22611-08-10Z 1</b>	3	-08	G1/2" - 14	16	-10	56.5	2.22	22.5	0.89	12.0	0.47	27	1.06	0.092	0.202
<b>22611-10-08Z 1</b>	3	-10	G5/8" - 14	12	-08	53.5	2.11	22.0	0.87	10.0	0.39	30	1.18	0.100	0.220
<b>22611-10-10Z</b>	3	-10	G5/8" - 14	16	-10	57.0	2.24	23.0	0.91	12.0	0.47	30	1.18	0.114	0.251
<b>22611-12-08TZ</b>	1	-12	G3/4" - 14	12	-08	51.5	2.03	20.0	0.79	10.0	0.39	32	1.26	0.130	0.286
<b>22611-12-10Z 1</b>	3	-12	G3/4" - 14	16	-10	57.5	2.26	23.5	0.93	12.0	0.47	32	1.26	0.126	0.277
<b>22611-12-12Z</b>	3	-12	G3/4" - 14	19	-12	62.5	2.46	24.0	0.94	15.0	0.59	32	1.26	0.132	0.290
<b>22611-16-12TZ</b>	1	-16	G1" - 11	19	-12	61.5	2.42	23.0	0.91	15.0	0.59	41	1.61	0.220	0.484
<b>22611-16-16Z 1</b>	3	-16	G1" - 11	25	-16	74.0	2.91	27.0	1.06	21.0	0.83	41	1.61	0.226	0.497
<b>22611-20-16TZ</b>	1	-20	G1 1/4" - 11	25	-16	74.0	2.91	27.0	1.06	21.0	0.83	50	1.97	0.350	0.770
<b>22611-24-20TZ</b>	1	-24	G1 1/2" - 11	31	-20	83.5	3.29	29.5	1.16	27.0	1.06	55	2.17	0.466	1.025
<b>22611-20-20WZ</b>	2	-20	G1 1/4" - 11	31	-20	84.5	3.33	30.5	1.20	27.0	1.06	50	1.97	0.406	0.893
<b>22611-24-24WZ</b>	2	-24	G1 1/2" - 11	38	-24	100.0	3.94	32.0	1.26	32.0	1.26	55	2.17	0.546	1.201
<b>22611-32-32WZ</b>	2	-32	G2" - 11	51	-32	103.0	4.06	31.0	1.22	43.0	1.69	70	2.76	0.960	2.112

- 1 Denotes Style 1 design
- 2 Denotes Style 2 wire nut design
- 3 Denotes Style 3 crimp nut design

# Winner

## Braided and spiral – standard fittings

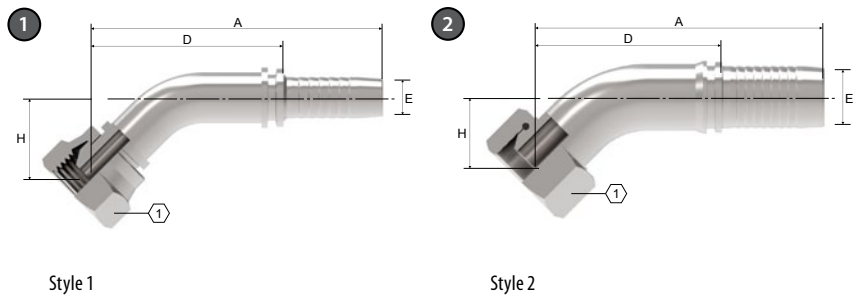

# 22641

BSP 60° Cone Female Swivel - 45° Elbow

Style 1

Style 2

PART	HOSE SIZE INFO					DIMENSIONS										WEIGHT	
	Winner 2pc part #	Ter- minal End	Thread	Hose Size		A		D Cut Off Factor		E Ø		H		1	Weight		
	STY.			DN	Dash Size	mm	in	mm	in	mm	in	mm	in	mm	in	kg	lb
<b>22641-04-04Z</b>	1	-04	G1/4" - 19	6	-04	70.3	2.77	42.3	1.67	4.0	0.16	20.2	0.80	19	0.75	0.046	0.101
<b>22641-06-04Z</b>	1	-06	G3/8" - 19	6	-04	71.2	2.80	43.2	1.70	4.0	0.16	21.1	0.83	22	0.87	0.055	0.121
<b>22641-06-06Z</b>	1	-06	G3/8" - 19	10	-06	76.9	3.03	46.9	1.85	7.0	0.28	22.6	0.89	22	0.87	0.070	0.154
<b>22641-08-06Z</b>	1	-06	G1/2" - 14	10	-06	76.7	3.02	48.1	1.89	7.0	0.28	23.9	0.94	27	1.06	0.104	0.229
<b>22641-08-08Z</b>	1	-08	G1/2" - 14	12	-08	92.6	3.65	61.1	2.41	10.0	0.39	26.1	1.03	27	1.06	0.130	0.286
<b>22641-10-10Z</b>	1	-10	G5/8" - 14	16	-10	106.1	4.18	72.1	2.84	12.0	0.47	27.8	1.09	30	1.18	0.196	0.431
<b>22641-12-12Z</b>	1	-12	G3/4" - 14	19	-12	117.1	4.61	78.6	3.09	15.0	0.59	31.8	1.25	32	1.26	0.285	0.627
<b>22641-16-16Z</b>	1	-16	G1" - 11	25	-16	135.4	5.33	88.4	3.48	21.0	0.83	34.2	1.35	41	1.61	0.402	0.884
<b>22641-20-20WZ</b>	2	-20	G1 1/4" - 11	31	-20	152.8	6.02	98.8	3.89	27.0	1.06	38.0	1.50	50	1.97	0.650	1.430
<b>22641-24-24WZ</b>	2	-24	G1 1/2" - 11	38	-24	184.2	7.25	116.2	4.57	32.0	1.26	45.5	1.79	55	2.17	1.095	2.409
<b>22641-32-32WZ</b>	2	-32	G2" - 11	51	-32	207.7	8.18	135.7	5.34	43.0	1.69	52.7	2.07	70	2.76	1.898	4.176

1 Denotes Style 1 design

2 Denotes Style 2 wire nut design

# 22691

BSP 60° Cone Female Swivel - 90° Elbow

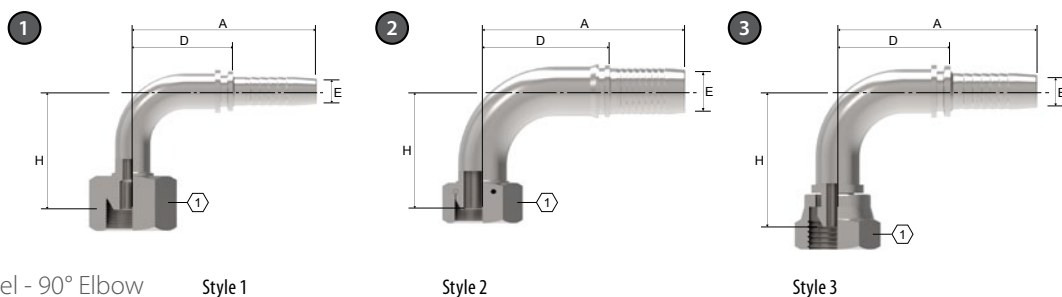

PART	HOSE SIZE INFO					DIMENSIONS								WEIGHT			
	Winner 2pc part #	Ter-minal End	Thread	Hose Size		A		D Cut Off Factor		E Ø		H		Weight			
	STY.			DN	Dash Size	mm	in	mm	in	mm	in	mm	in	mm	in	kg	lb
<b>22691-04-04Z</b>	3	-04	G1/4" - 19	6	-4	58.0	2.28	30.0	1.18	4.0	0.16	36.5	1.44	19	0.75	0.048	0.106
<b>22691-04-05Z 1</b>	3	-04	G1/4" - 19	8	-5	61.0	2.40	33.0	1.30	5.5	0.22	39.5	1.56	19	0.75	0.060	0.132
<b>22691-04-06Z 1</b>	3	-04	G1/4" - 19	10	-6	60.0	2.36	30.0	1.18	7.0	0.28	36.5	1.44	19	0.75	0.055	0.121
<b>22691-06-04TZ</b>	1	-06	G3/8" - 19	6	-4	58.0	2.28	30.0	1.18	4.0	0.16	37.7	1.48	22	0.87	0.070	0.154
<b>22691-06-06Z</b>	3	-06	G3/8" - 19	10	-6	65.3	2.57	35.3	1.39	7.0	0.28	43.0	1.69	22	0.87	0.080	0.176
<b>22691-06-08Z 1</b>	3	-06	G3/8" - 19	12	-8	72.5	2.85	41.0	1.61	10.0	0.39	49.2	1.94	22	0.87	0.126	0.277
<b>22691-08-06TZ</b>	1	-08	G1/2" - 14	10	-6	65.3	2.57	35.3	1.39	7.0	0.28	41.8	1.65	27	1.06	0.115	0.253
<b>22691-08-08Z</b>	3	-08	G1/2" - 14	12	-8	72.5	2.85	41.0	1.61	10.0	0.39	51.0	2.01	27	1.06	0.134	0.293
<b>22691-10-08Z 1</b>	3	-10	G5/8" - 14	12	-8	72.5	2.85	41.0	1.61	10.0	0.39	51.5	2.03	30	1.18	0.160	0.352
<b>22691-10-10Z</b>	3	-10	G5/8" - 14	16	-10	90.0	3.54	56.0	2.20	12.0	0.47	56.0	2.20	30	1.18	0.218	0.480
<b>22691-12-10Z 1</b>	3	-12	G3/4" - 14	16	-10	90.0	3.54	56.0	2.20	12.0	0.47	56.6	2.23	32	1.26	0.228	0.502
<b>22691-12-12Z</b>	3	-12	G3/4" - 14	19	-12	103.4	4.07	64.9	2.56	15.0	0.59	66.1	2.60	32	1.26	0.330	0.726
<b>22691-16-12TZ 2</b>	3	-16	G1" - 11	19	-12	104.0	4.09	65.5	2.58	15.0	0.59	63.8	2.51	41	1.61	0.360	0.660
<b>22691-16-16Z</b>	3	-16	G1" - 11	25	-16	123.7	4.87	76.7	3.02	21.0	0.83	73.8	2.91	41	1.61	0.495	1.089
<b>22691-20-20WZ</b>	2	-20	G1 1/4" - 11	31	-20	145.5	5.73	91.5	3.60	27.0	1.06	84.3	3.32	50	1.97	0.775	1.705
<b>22691-24-24WZ</b>	2	-24	G1 1/2" - 11	38	-24	177.4	6.98	109.4	4.31	32.0	1.26	103.0	4.06	55	2.17	1.395	3.069
<b>22691-32-32WZ</b>	2	-32	G2" - 11	51	-32	203.8	8.02	131.8	5.19	43.0	1.69	123.3	4.85	70	2.76	2.360	5.192

- 1 Denotes Style 1 design
- 2 Denotes Style 2 wire nut design
- 3 Denotes Style 3 crimp nut design

# Winner

## Braided and spiral – standard fittings

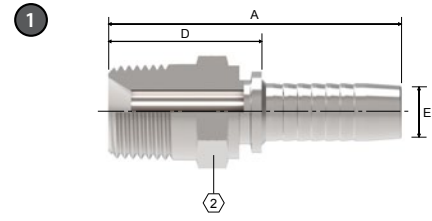

# 15611

NPTF Male

PART		HOSE SIZE INFO				DIMENSIONS							WEIGHT	
Winner 2pc part #	Terminal End	Thread	Hose Size		A		D Cut Off Factor		E Ø		2		Weight	
			DN	Dash Size	mm	in	mm	in	mm	in	mm	in	kg	lb
<b>15611-F02-04Z</b>	-02	1/8" - 27	6	-04	50.5	1.99	22.5	0.89	4.0	0.16	12	0.47	0.015	0.033
<b>15611-F04-04Z</b>	-04	1/4" - 18	6	-04	56.0	2.20	28.0	1.10	4.0	0.16	17	0.67	0.030	0.066
<b>15611-F04-06Z</b>	-04	1/4" - 18	10	-06	57.5	2.26	27.5	1.08	7.0	0.28	17	0.67	0.032	0.070
<b>15611-F06-04Z</b>	-06	3/8" - 18	6	-04	57.0	2.24	29.0	1.14	4.0	0.16	19	0.75	0.038	0.084
<b>15611-F06-06Z</b>	-06	3/8" - 18	10	-06	59.0	2.32	29.0	1.14	7.0	0.28	19	0.75	0.048	0.106
<b>15611-F06-08Z</b>	-06	3/8" - 18	12	-08	62.0	2.44	30.5	1.20	9.0	0.35	19	0.75	0.060	0.132
<b>15611-F08-04Z</b>	-08	1/2" - 14	6	-04	62.3	2.45	34.3	1.35	4.0	0.16	22	0.87	0.066	0.145
<b>15611-F08-06Z</b>	-08	1/2" - 14	10	-06	64.3	2.53	34.3	1.35	7.0	0.28	22	0.87	0.068	0.150
<b>15611-F08-08Z</b>	-08	1/2" - 14	12	-08	66.0	2.60	34.5	1.36	10.0	0.39	22	0.87	0.075	0.165
<b>15611-F08-10Z</b>	-08	1/2" - 14	16	-10	70.0	2.76	36.0	1.42	12.0	0.47	22	0.87	0.085	0.187
<b>15611-F08-12Z</b>	-08	1/2" - 14	19	-12	77.0	3.03	38.5	1.52	15.0	0.59	27	1.06	0.124	0.273
<b>15611-F12-08Z</b>	-12	3/4" - 14	12	-08	69.3	2.73	37.8	1.49	10.0	0.39	27	1.06	0.103	0.227
<b>15611-F12-10Z</b>	-12	3/4" - 14	16	-10	71.5	2.81	37.5	1.48	12.0	0.47	30	1.06	0.130	0.286
<b>15611-F12-12Z</b>	-12	3/4" - 14	19	-12	77.0	3.03	38.5	1.52	15.0	0.59	30	1.06	0.130	0.286
<b>15611-F12-16Z</b>	-12	3/4" - 14	25	-16	86.3	3.40	39.3	1.55	21.0	0.83	32	1.26	0.190	0.418
<b>15611-F16-12Z</b>	-16	1-11" 1/2	19	-12	82.6	3.25	44.1	1.74	15.0	0.59	36	1.42	0.210	0.462
<b>15611-F16-16Z</b>	-16	1-11" 1/2	25	-16	93.5	3.68	46.5	1.83	21.0	0.83	36	1.42	0.230	0.506
<b>15611-F20-16Z</b>	-20	1 1/4" - 11.5	25	-16	96.5	3.80	49.5	1.95	21.0	0.83	46	1.81	0.344	0.757
<b>15611-F20-20Z</b>	-20	1 1/4" - 11.5	31	-20	103.4	4.07	49.4	1.94	27.0	1.06	46	1.81	0.406	0.893
<b>15611-F24-24Z</b>	-24	1 1/2" - 11.5	38	-24	119.2	4.69	51.2	2.02	32.0	1.26	50	1.97	0.550	1.210
<b>15611-F32-32Z</b>	-32	2" - 11.5	51	-32	127.0	5.00	55.0	2.17	43.0	1.69	65	2.56	0.945	2.079

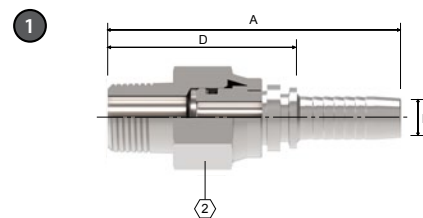

# 15611SW

NPTF Male Swivel

PART	HOSE SIZE INFO				DIMENSIONS								WEIGHT	
Winner 2pc part #	Terminal End	Thread	Hose Size		A		D Cut Off Factor		E Ø		2		Weight	
			DN	Dash Size	mm	in	mm	in	mm	in	mm	in	kg	lb
<b>15611SW-F04-04SZ</b>	-04	1/4" - 18	6	-04	76.0	2.99	48.0	1.89	4.0	0.16	19	0.75	0.064	0.141
<b>15611SW-F06-06SZ</b>	-06	3/8" - 18	10	-06	85.0	3.35	55.0	2.17	7.0	0.28	22	0.87	0.100	0.220
<b>15611SW-F08-06SZ</b>	-08	1/2" - 14	10	-06	87.0	3.43	57.0	2.24	7.0	0.28	22	0.87	0.152	0.334
<b>15611SW-F08-08SZ</b>	-08	1/2" - 14	12	-08	88.5	3.49	57.0	2.24	10.0	0.39	27	1.06	0.152	0.334
<b>15611SW-F12-12SZ</b>	-12	3/4" - 14	20	-12	99.0	3.90	60.5	2.38	15.0	0.59	32	1.26	0.225	0.495
<b>15611SW-F16-16SZ</b>	-16	1" - 11.5	25	-16	116.5	4.59	69.5	2.74	21.0	0.83	41	1.61	0.375	0.825

# Winner

## Braided and spiral – standard fittings

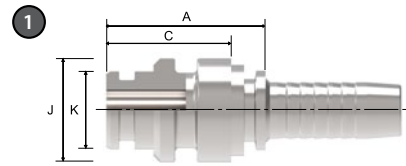

# 60011

Staple-Lock Male - DN Series D Type

PART		HOSE SIZE INFO			DIMENSIONS							
Winner 2pc part #	Terminal End	Hose Size		O-RNG Hose Size	A		C		J		K	
	DN	DN	Dash Size		mm	in	mm	in	mm	in	mm	in
<b>60011-04-04DZ</b>	-04	6	4	O06.0 x 2.0	36.0	1.42	29.0	1.14	15.0	0.59	10.0	0.39
<b>60011-06-06DZ</b>	-06	10	6	O10.0 x 2.0	36.0	1.42	29.0	1.14	20.0	0.79	14.0	0.55
<b>60011-08-08DZ</b>	-08	12	8	O10.0 x 2.0	36.5	1.44	29.0	1.14	24.0	0.94	18.0	0.71
<b>60011-10-10DZ</b>	-10	16	10	O10.0 x 2.0	38.5	1.52	30.0	1.18	25.0	0.98	20.0	0.79
<b>60011-12-12DZ</b>	-12	19	12	O19.0 x 2.5	38.0	1.50	29.0	1.14	29.0	1.14	24.0	0.94
<b>60011-16-16DZ</b>	-16	25	16	O25.0 x 2.5	45.0	1.77	35.0	1.38	39.0	1.54	31.0	1.22
<b>60011-20-20DZ</b>	-20	31	20	O33.0 x 2.5	53.0	2.09	41.0	1.61	46.0	1.81	38.0	1.50
<b>60011-24-24DZ</b>	-24	38	24	O40.0 x 3.0	53.0	2.09	40.0	1.57	55.0	2.17	47.0	1.85
<b>60011-32-32DZ</b>	-32	51	32	O49.0 x 3.0	51.0	2.01	40.0	1.57	64.0	2.52	56.0	2.20

Socket type by hose

Winner 2pc fittings					
Hose part #	Socket:	Hose part #	Socket:	Hose part #	Socket:
EC110	00110	EC118	00110 & 03310	WH006	000T8
EC115	00110	EC082	00110	WH007	000T8
EC210	03310	WH004	03310	EC426	4W
EC215	03310	WH005	000T8	EC330	4W



# Winner

---

Braided and spiral – standard fittings

Aeroquip by Danfoss

# Spiral fittings

1T/4S & 6S Series



## Spiral - 1T/4S &amp; 6S Series

# DK

DIN 24° DKO Light Male (DK)

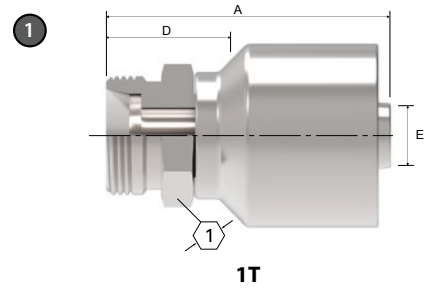

PART	HOSE SIZE INFO				DIMENSIONS							
1 1T part #	Terminal End	Hose Size		Thread	A		D		E Ø		1	
		DN	Dash Size	Metric	mm	in	mm	in	mm	in	mm	in
<b>1T10DK6</b>	12L	10	-06	M18 x 1.5	53.5	2.11	24.0	0.95	6.5	0.26	19	0.75
<b>1T12DK8</b>	15L	12	-08	M22 x 1.5	58.0	2.29	25.0	0.99	9.1	0.36	24	0.94
<b>1T16DK10</b>	18L	16	-10	M26 x 1.5	62.0	2.44	25.4	1.00	12.1	0.48	32	1.26

# DL

DIN 24° DKO Light Female Swivel (DL)

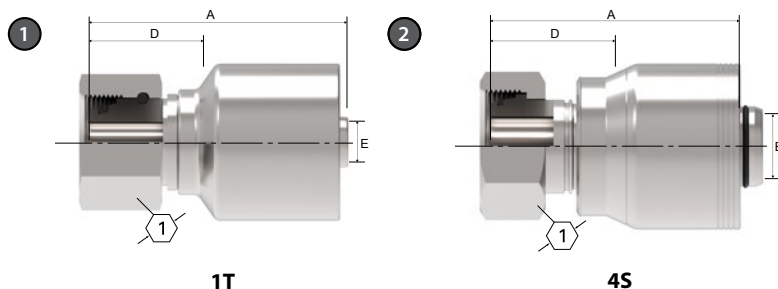

PART	HOSE SIZE INFO				DIMENSIONS							
<b>1</b> 1T part #	Terminal End	Hose Size		Thread	A		D		E Ø			
		DN	Dash Size	Metric	mm	in	mm	in	mm	in	mm	in
<b>1T10DL6</b>	12L	10	-06	M18 x 1.5	55.0	2.17	25.5	1.00	6.6	0.26	22	0.87
<b>1T12DL8</b>	15L	12	-08	M22 x 1.5	58.0	2.29	25.0	0.99	8.0	0.32	27	1.06
<b>1T16DL10</b>	18L	16	-10	M26 x 1.5	62.0	2.44	25.4	1.00	12.1	0.48	32	1.26
<b>2</b> 4S part #	Terminal End	Hose Size		Thread	A		D		E Ø			
		DN	Dash Size	Metric	mm	in	mm	in	mm	in	mm	in
<b>4S20DL12</b>	22L	19	-12	M30 x 2.0	76.0	2.99	39.7	1.56	14.2	0.56	36	1.42
<b>4S25DL16</b>	28L	25	-16	M36 x 2.0	79.7	3.14	40.3	1.59	19.2	0.76	41	1.61
<b>4S32DL20</b>	35L	31	-20	M45 x 2.0	100.5	3.96	45.5	1.79	25.2	0.99	50	1.97

## Spiral - 1T/4S &amp; 6S Series

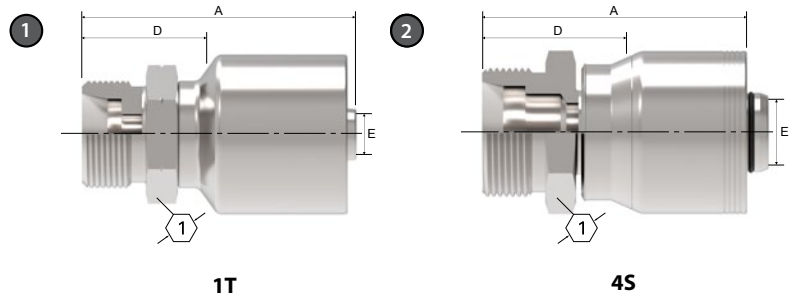

# EK

DIN 24° DKO Heavy Male (EK)

PART		HOSE SIZE INFO			DIMENSIONS							
1 1T part #	Terminal End	Hose Size		Thread	A		D		E Ø		1	
		DN	Dash Size	Metric	mm	in	mm	in	mm	in	mm	in
<b>1T8EK6</b>	12S	10	-06	M20 x 1.5	54.0	2.13	24.5	0.97	6.5	0.26	22	0.87
<b>1T12EK8</b>	16S	12	-08	M24 x 1.5	60.0	2.36	27.0	1.06	9.0	0.35	27	1.06
<b>1T16EK10</b>	20S	16	-10	M30 x 2.0	68.0	2.68	31.4	1.24	12.0	0.47	32	1.26
2 4S part #	Terminal End	Hose Size		Thread	A		D		E Ø		1	
		DN	Dash Size	Metric	mm	in	mm	in	mm	in	mm	in
<b>4S20EK12</b>	25S	19	-12	M36 x 2.0	78.6	3.09	42.3	1.67	14.2	0.56	41	1.61
<b>4S25EK16</b>	30S	25	-16	M42 x 2.0	83.7	3.30	44.0	1.73	19.2	0.75	46	1.81
<b>4S32EK20</b>	38S	31	-20	M52 x 2.0	106.9	4.21	51.7	2.04	25.2	0.99	55	2.16

# DS

DIN 24° DKO Heavy Female Swivel (DS)

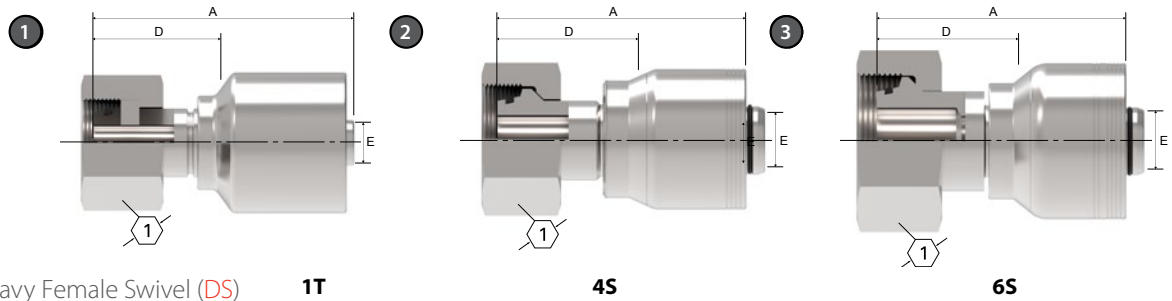
**1T**
**4S**
**6S**

PART	HOSE SIZE INFO				DIMENSIONS							
	Terminal End	Hose Size		Thread	A		D		E Ø		1	
1T part #		DN	Dash Size	Metric	mm	in	mm	in	mm	in	mm	in
<b>1T8DS6</b>	12S	10	-06	M20 x 1.5	58.2	2.29	28.7	1.13	6.5	0.26	24	0.94
<b>1T12DS8</b>	16S	12	-08	M24 x 1.5	65.0	2.56	32.0	1.26	9.0	0.35	30	1.18
<b>1T12DS10</b>	16S	12	-8	M24 x 1.5	62.5	2.46	25.9	1.02	12.1	0.48	30	1.18
<b>1T16DS10</b>	20S	16	-10	M30 x 2.0	73.3	2.89	36.7	1.44	12.0	0.47	36	1.42
<b>2</b>	4S part #	Hose Size		Thread	A		D		E Ø		1	
	Terminal End											
<b>4S16DS12</b>	20S	19	-12	M30 x 2.0	73.7	2.90	37.4	1.47	14.2	0.56	36	1.42
<b>4S20DS12</b>	25S	19	-12	M36 x 2.0	86.6	3.41	50.3	1.98	14.2	0.56	46	1.81
<b>4S25DS12</b>	30S	19	-12	M42 x 2.0	88.2	3.47	51.9	2.04	14.2	0.56	50	1.97
<b>4S25DS16</b>	30S	25	-16	M42 x 2.0	91.1	3.59	51.4	2.02	19.2	0.76	50	1.97
<b>4S32DS16</b>	38S	25	-16	M52 x 2.0	94.5	3.72	55.3	2.18	19.2	0.76	60	2.36
<b>4S25DS20</b>	30S	31	-20	M42 x 2.0	96.6	3.80	41.6	1.64	22.1	0.87	50	1.97
<b>4S32DS20</b>	38S	31	-20	M52 x 2.0	111.5	4.39	56.5	2.22	25.2	0.99	60	2.36
<b>3</b>	6S part #	Hose Size		Thread	A		D		E Ø		1	
	Terminal End											
<b>6S25DS16</b>	30S	25	-16	M42 x 2.0	91.1	3.59	51.4	2.02	19.2	0.76	50	1.97
<b>6S32DS16</b>	38S	25	-16	M52 x 2.0	95.0	3.74	55.3	2.18	19.2	0.76	60	2.36
<b>6S32DS20</b>	38S	31	-20	M52 x 2.0	112.5	4.43	56.5	2.22	25.2	0.99	60	2.36

## Spiral - 1T/4S &amp; 6S Series

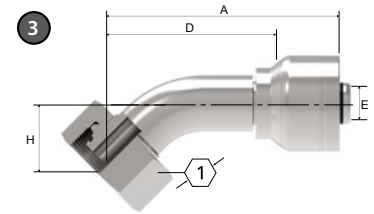
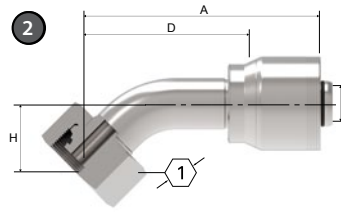
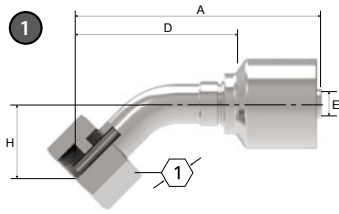

# DSA

**1T**
**4S**
**6S**

DIN 24° DKO Heavy Female Swivel - 45° Elbow (DSA)

PART		HOSE SIZE INFO			DIMENSIONS											
<b>1</b> 1T part #	Terminal End	Hose Size		Thread	A		D		E Ø		H					
		DN	Dash Size	Metric	mm	in	mm	in	mm	in	mm	in	mm	in		
		<b>1T8DSA6</b>	12S	10	-06	M20 x 1.5	73.9	2.90	44.5	1.75	6.6	0.26	17.0	0.67	24	0.94
<b>1T12DSA8</b>	16S	12	-08	M24 x 1.5	96.0	3.78	63.0	2.48	9.1	0.36	28.5	1.12	30	1.18		
<b>1T16DSA10</b>	20S	16	-10	M30 x 2.0	105.5	4.15	68.8	2.71	12.1	0.48	31.0	1.22	36	1.42		
<b>2</b> 4S part #	Terminal End	Hose Size		Thread	A		D		E Ø		H					
		DN	Dash Size	Metric	mm	in	mm	in	mm	in	mm	in	mm	in		
		<b>4S20DSA12</b>	25S	19	-12	M36 x 2.0	116.7	4.59	80.4	3.17	14.2	0.56	32.0	1.26	46	1.81
		<b>4S25DSA12</b>	30S	19	-12	M42 x 2.0	130.8	5.15	94.4	3.72	14.2	0.56	35.0	1.38	50	1.97
		<b>4S25DSA16</b>	30S	25	-16	M42 x 2.0	134.2	5.28	94.4	3.72	19.2	0.76	35.0	1.38	50	1.97
		<b>4S32DSA16</b>	38S	25	-16	M52 x 2.0	145.1	5.71	105.3	4.15	19.2	0.76	39.0	1.54	60	2.36
<b>4S32DSA20</b>	38S	31	-20	M52 x 2.0	161.3	6.35	106.3	4.19	25.2	0.99	39.0	1.54	60	2.36		
<b>3</b> 6S part #	Terminal End	Hose Size		Thread	A		D		E Ø		H					
		DN	Dash Size	Metric	mm	in	mm	in	mm	in	mm	in	mm	in		
		<b>6S25DSA16</b>	30S	25	-16	M42 x 2.0	134.1	5.28	94.4	3.72	19.2	0.76	35.0	1.38	50	1.97
		<b>6S32DSA16</b>	38S	25	-16	M52 x 2.0	145.1	5.71	105.3	4.15	19.2	0.76	39.0	1.54	60	2.36
<b>6S32DSA20</b>	38S	31	-20	M52 x 2.0	162.4	6.39	106.3	4.19	25.2	0.99	39.0	1.54	60	2.36		

# DSB

DIN 24° DKO Heavy Female Swivel - 90° Elbow (DSB)

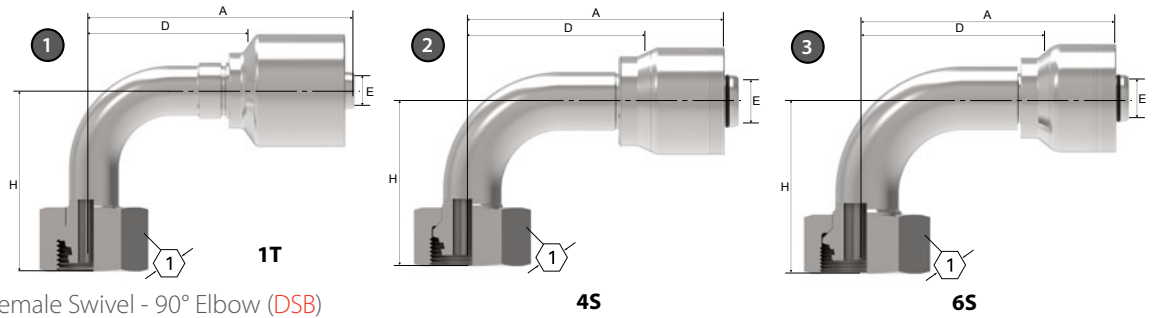

PART	HOSE SIZE INFO				DIMENSIONS									
	Terminal End	Hose Size		Thread	A		D		E Ø		H		1	
1T part #		DN	Dash Size	Metric	mm	in	mm	in	mm	in	mm	in	mm	in
<b>1T8DSB6</b>	12S	10	-06	M20 x 1.5	67.4	2.65	37.9	1.49	6.6	0.26	37.0	1.46	24	0.94
<b>1T12DSB8</b>	16S	12	-08	M24 x 1.5	83.0	3.27	50.0	1.97	9.1	0.36	55.0	2.17	30	1.18
<b>1T12DSB10</b>	16S	16	-10	M24 x 1.5	87.5	3.44	50.9	2.00	12.1	0.48	50.5	1.99	30	1.18
<b>1T16DSB10</b>	20S	16	-10	M30 x 2.0	92.0	3.62	55.4	2.18	12.1	0.48	61.5	2.42	36	1.42
<b>2</b>	Terminal End	Hose Size		Thread	A		D		E Ø		H		1	
4S part #														
<b>4S20DSB12</b>	25S	19	-12	M36 x 2.0	103.9	4.09	67.7	2.67	14.2	0.56	65.0	2.56	46	1.81
<b>4S25DSB12</b>	30S	19	-12	M42 x 2.0	122.7	4.83	86.4	3.40	14.2	0.56	76.0	2.99	50	1.97
<b>4S25DSB16</b>	30S	25	-16	M42 x 2.0	124.5	4.90	84.8	3.34	19.2	0.76	76.0	2.99	50	1.97
<b>4S32DSB16</b>	38S	25	-16	M52 x 2.0	136.7	5.38	97.0	3.82	19.2	0.76	89.0	3.50	60	2.36
<b>4S32DSB20</b>	38S	31	-20	M52 x 2.0	153.0	6.02	98.0	3.86	25.2	0.99	89.0	3.50	60	2.36
<b>3</b>	Terminal End	Hose Size		Thread	A		D		E Ø		H		1	
6S part #														
<b>6S25DSB16</b>	30S	25	-16	M42 x 2.0	124.5	4.90	84.8	3.34	19.2	0.76	76.0	2.99	50	1.97
<b>6S32DSB16</b>	38S	25	-16	M52 x 2.0	136.7	5.38	97.0	3.82	19.2	0.76	89.0	3.50	60	2.36
<b>6S32DSB20</b>	38S	31	-20	M52 x 2.0	154.2	6.07	98.0	3.86	25.2	0.99	89.0	3.50	60	2.36

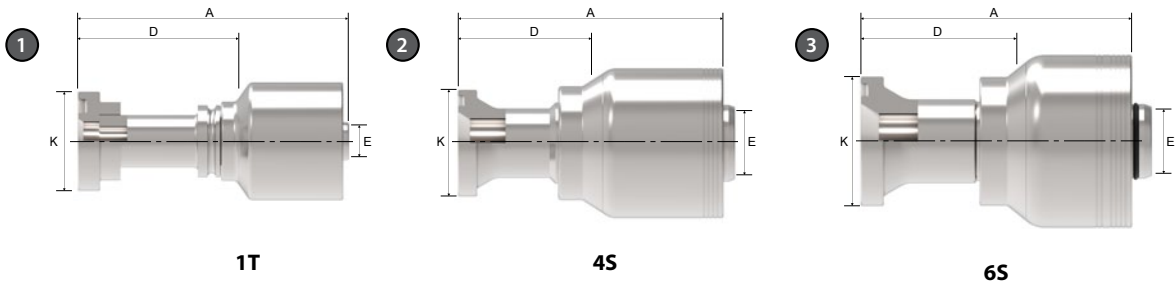

## Spiral - 1T/4S &amp; 6S Series

**FL**

SAE CODE 61 Flange (FL)

PART	HOSE SIZE INFO					DIMENSIONS					
<b>1</b> 1T part #	Terminal End	Hose Size		Flange Head Dia. K Ø		A		D		E Ø	
				mm	in	mm	in	mm	in	mm	in
		DN	Dash Size								
<b>1T8FL8</b>	-08	12	-08	30.2	1.19	83.0	3.27	50.0	1.97	9.0	0.35
<b>1T12FL10</b>	-12	16	-10	38.1	1.50	94.0	3.70	57.4	2.26	12.0	0.47
<b>2</b> 4S part #	Terminal End	Hose Size		Flange Head Dia. K Ø		A		D		E Ø	
				mm	in	mm	in	mm	in	mm	in
		DN	Dash Size								
<b>4S12FL12</b>	-12	19	-12	38.1	1.50	90.7	3.57	54.5	2.15	14.2	0.56
<b>4S16FL12</b>	-16	19	-12	44.5	1.75	90.2	3.55	54.0	2.13	14.2	0.56
<b>4S20FL12</b>	-20	19	-12	50.8	2.00	97.7	3.85	61.5	2.42	14.2	0.56
<b>4S16FL16</b>	-16	25	-16	44.5	1.75	93.3	3.67	53.6	2.11	19.2	0.76
<b>4S20FL16</b>	-20	25	-16	50.8	2.00	100.8	3.97	61.1	2.41	19.2	0.76
<b>4S24FL16</b>	-24	25	-16	60.4	2.38	97.4	3.83	57.7	2.27	19.2	0.76
<b>4S16FL20</b>	-16	31	-20	44.5	1.75	110.5	4.35	55.5	2.18	25.2	0.99
<b>4S20FL20</b>	-20	31	-20	50.8	2.00	117.4	4.62	62.2	2.45	25.2	0.99
<b>4S24FL20</b>	-24	31	-20	60.4	2.38	106.7	4.20	51.6	2.03	25.2	0.99
<b>4S32FL20</b>	-32	31	-20	71.4	2.81	104.9	4.13	49.9	1.96	25.2	0.99
<b>4S24FL24</b>	-24	38	-24	60.4	2.38	171.6	6.75	93.6	3.68	31.1	1.22
<b>4S32FL24</b>	-32	38	-24	71.4	2.81	174.7	6.88	96.7	3.81	31.1	1.22
<b>4S32FL32</b>	-32	51	-32	71.4	2.81	177.5	6.99	99.5	3.92	42.1	1.66
<b>3</b> 6S part #	Terminal End	Hose Size		Flange Head Dia. K Ø		A		D		E Ø	
				mm	in	mm	in	mm	in	mm	in
		DN	Dash Size								
<b>6S16FL16</b>	-16	25	-16	44.5	1.75	93.3	3.67	53.6	2.11	19.2	0.76
<b>6S20FL20</b>	-20	31	-20	50.8	2.00	118.2	4.65	62.2	2.45	25.2	0.99
<b>6S24FL24</b>	-24	38	-24	60.4	2.38	171.6	6.75	93.6	3.68	31.1	1.22
<b>6S32FL24</b>	-32	38	-24	71.4	2.81	174.7	6.88	96.7	3.81	31.1	1.22
<b>6S32FL32</b>	-32	51	-32	71.4	2.81	177.5	6.99	99.5	3.92	42.1	1.66

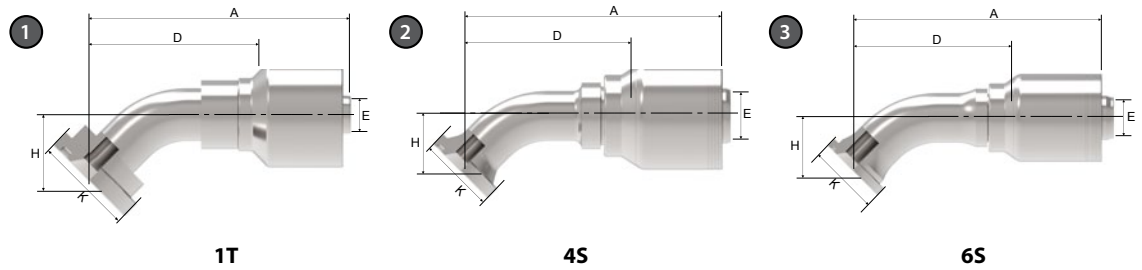

# FLA

SAE CODE 61 Flange - 45° Elbow (FLA)

PART		HOSE SIZE INFO				DIMENSIONS							
① 1T part#	Termi- nal End	Hose Size		Flange Head Dia. K Ø		A		D		E Ø		H	
						mm	in	mm	in	mm	in	mm	in
<b>1T8FLA8</b>	-08	12	-08	30.2	1.90	91.7	3.61	58.7	2.31	9.0	0.35	23.0	0.91
<b>1T12FLA10</b>	-12	16	-10	38.1	1.50	100.7	3.97	64.1	2.53	12.0	0.47	25.3	1.00
② 4S part#	Termi- nal End	Hose Size		Flange Head Dia. K Ø		A		D		E Ø		H	
						mm	in	mm	in	mm	in	mm	in
<b>4S12FLA12</b>	-12	19	-12	38.1	1.50	113.8	4.48	77.6	3.06	14.2	0.56	27.0	1.06
<b>4S16FLA12</b>	-16	19	-12	44.4	1.75	127.9	5.04	91.7	3.61	14.2	0.56	32.0	1.26
<b>4S12FLA16</b>	-12	25	-16	38.1	1.50	116.9	4.60	77.2	3.04	19.2	0.76	27.0	1.06
<b>4S16FLA16</b>	-16	25	-16	44.4	1.75	131.0	5.16	91.3	3.59	19.2	0.76	32.0	1.26
<b>4S20FLA16</b>	-16	31	-20	50.8	2.00	150.2	5.91	110.5	4.35	19.2	0.76	39.0	1.54
<b>4S16FLA20</b>	-20	25	-16	44.4	1.75	152.1	5.99	97.0	3.82	25.2	0.99	32.0	1.26
<b>4S20FLA20</b>	-20	31	-20	50.8	2.00	166.8	6.57	111.6	4.39	25.2	0.99	39.0	1.54
<b>4S24FLA20</b>	-24	31	-20	60.4	2.38	161.6	6.36	106.6	4.20	25.2	0.99	39.5	1.34
<b>4S24FLA24</b>	-24	38	-24	60.3	2.37	214.3	8.44	136.3	5.37	31.1	1.22	45.0	1.77
<b>4S32FLA24</b>	-32	38	-24	71.4	2.81	251.0	9.88	173.0	6.81	31.1	1.22	57.5	2.26
<b>4S32FLA32</b>	-32	51	-32	71.4	2.81	253.9	10.00	175.9	6.92	42.1	1.66	57.5	2.26
③ 6S part#	Termi- nal End	Hose Size		Flange Head Dia. K Ø		A		D		E Ø		H	
						mm	in	mm	in	mm	in	mm	in
<b>6S16FLA16</b>	-16	25	-16	44.4	1.75	131.0	5.16	91.3	3.59	19.2	0.76	32.0	1.26
<b>6S20FLA16</b>	-20	25	-16	50.8	2.00	150.2	5.91	110.5	4.35	19.2	0.76	39.0	1.54
<b>6S20FLA20</b>	-20	31	-20	50.8	2.00	167.6	6.60	111.6	4.39	25.2	0.99	39.0	1.54
<b>6S24FLA24</b>	-24	38	-24	60.3	2.37	214.3	8.44	136.3	5.37	31.1	1.22	45.0	1.77
<b>6S32FLA24</b>	-32	38	-24	71.4	2.81	251.0	9.88	173.0	6.81	31.1	1.22	57.5	2.26
<b>6S32FLA32</b>	-32	51	-32	71.4	2.81	253.9	10.00	175.9	6.92	42.1	1.66	57.5	2.26

## Spiral - 1T/4S &amp; 6S Series

# FLB

SAE CODE 61 Flange - 90° Elbow (FLB)

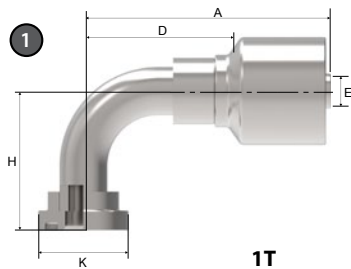
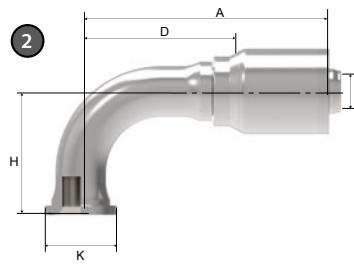
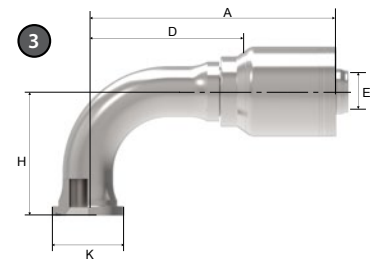
**1T**

**4S**

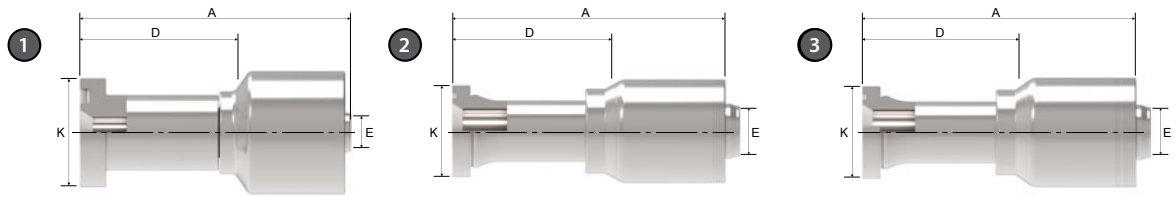
**6S**

PART	HOSE SIZE INFO					DIMENSIONS							
<b>1</b> 1T part #	Termi- nal End	Hose Size		Flange Head Dia. K Ø		A		D		E Ø		H	
		DN	Dash Size	mm	in	mm	in	mm	in	mm	in	mm	in
<b>1T8FLB8</b>	-08	12	-08	30.2	1.19	83.5	3.29	50.5	1.99	9.0	0.35	47.0	1.85
<b>1T12FLB10</b>	-12	16	-10	38.1	1.50	93.3	3.68	56.7	2.23	12.0	0.47	53.8	2.12
<b>2</b> 4S part #	Termi- nal End	Hose Size		Flange Head Dia. K Ø		A		D		E Ø		H	
		DN	Dash Size	mm	in	mm	in	mm	in	mm	in	mm	in
<b>4S12FLB12</b>	-12	19	-12	38.1	1.50	108.5	4.27	72.3	2.85	14.2	0.56	59.0	2.32
<b>4S16FLB12</b>	-16	19	-12	44.4	1.75	122.8	4.84	86.6	3.41	14.2	0.56	71.0	2.80
<b>4S20FLB12</b>	-20	19	-12	50.8	2.00	108.5	4.72	72.3	2.85	14.2	0.56	65.0	2.56
<b>4S16FLB16</b>	-16	25	-16	44.4	1.75	126.0	4.96	86.2	3.39	19.2	0.76	71.0	2.80
<b>4S16FLB16.116</b>	-16	25	-16	44.4	1.75	126.0	4.96	86.2	3.39	19.2	0.76	116.0	4.57
<b>4S20FLB16</b>	-20	25	-16	50.8	2.00	145.2	5.72	105.4	4.15	19.2	0.76	89.0	3.50
<b>4S24FLB16</b>	-24	25	-16	60.4	2.38	136.5	5.37	96.8	3.81	19.2	0.76	81.9	3.22
<b>4S16FLB20</b>	-16	31	-20	44.4	1.75	147.1	5.79	91.9	3.62	25.2	0.99	71.0	2.80
<b>4S20FLB20</b>	-20	31	-20	50.8	2.00	161.8	6.37	106.5	4.19	25.2	0.99	89.0	3.50
<b>4S24FLB20</b>	-24	31	-20	60.4	2.38	152.9	6.02	97.9	3.85	25.2	0.99	81.9	3.22
<b>4S24FLB24</b>	-24	38	-24	60.3	2.37	208.9	8.22	130.9	5.15	31.1	1.22	104.0	4.09
<b>4S32FLB24</b>	-32	38	-24	71.4	2.81	247.4	9.74	169.4	6.67	31.1	1.22	138.0	5.43
<b>4S32FLB32</b>	-32	51	-32	71.4	2.81	250.3	9.85	172.2	6.78	42.1	1.66	138.0	5.43
<b>3</b> 6S part #	Termi- nal End	Hose Size		Flange Head Dia. K Ø		A		D		E Ø		H	
		DN	Dash Size	mm	in	mm	in	mm	in	mm	in	mm	in
<b>6S16FLB16</b>	-16	25	-16	44.4	1.75	126.0	4.96	86.2	3.39	19.2	0.76	71.0	2.80
<b>6S20FLB16</b>	-20	25	-16	50.8	2.00	145.2	5.72	105.4	4.15	19.2	0.76	89.0	3.50
<b>6S20FLB20</b>	-20	31	-20	50.8	2.00	162.5	6.40	106.5	4.19	25.2	0.99	89.0	3.50
<b>6S24FLB24</b>	-24	38	-24	60.3	2.37	208.8	8.22	130.8	5.15	31.1	1.22	104.0	4.09
<b>6S32FLB24</b>	-32	38	-24	71.4	2.81	247.4	9.74	169.4	6.67	31.1	1.22	138.0	5.43
<b>6S32FLB32</b>	-32	51	-32	71.4	2.81	250.3	9.85	172.2	6.78	42.1	1.66	138.0	5.43



# FH

SAE CODE 62 Flange (FH)

**1T**
**4S**
**6S**

PART	HOSE SIZE INFO				DIMENSIONS						
<b>1</b> 1T part #	Terminal End	Hose Size		Flange Head Dia. K Ø		A		D		E Ø	
		DN	Dash Size	mm	in	mm	in	mm	in	mm	in
<b>1T8FH8</b>	-08	12	-08	31.8	1.25	80.7	3.18	47.7	1.88	9.0	0.35
<b>1T12FH8</b>	-12	12	-08	41.3	1.63	84.5	3.33	51.5	2.03	9.0	0.35
<b>1T8FH10</b>	-8	16	-10	31.8	1.25	87.2	3.44	50.6	1.99	12.0	0.47
<b>1T12FH10</b>	-12	16	-10	41.3	1.63	90.5	3.57	53.9	2.12	12.0	0.47
<b>1T16FH10</b>	-16	16	-10	47.6	1.87	104.5	4.11	67.9	2.68	12.1	0.48
<b>2</b> 4S part #	Terminal End	Hose Size		Flange Head Dia. K Ø		A		D		E Ø	
		mm	in	mm	in	mm	in	mm	in	mm	in
<b>4S12FH12</b>	-12	19	-12	41.3	1.63	90.7	3.57	54.5	2.15	14.2	0.56
<b>4S16FH12</b>	-16	19	-12	47.7	1.88	90.2	3.55	54.0	2.13	14.2	0.56
<b>4S12FH16</b>	-12	25	-16	41.3	1.63	96.3	3.79	56.7	2.23	14.2	0.56
<b>4S16FH16</b>	-16	25	-16	47.7	1.88	98.9	3.89	59.1	2.33	19.2	0.76
<b>4S20FH16</b>	-20	25	-16	54.0	2.13	100.8	3.97	61.0	2.40	19.2	0.76
<b>4S16FH20</b>	-16	31	-20	47.7	1.88	123.8	4.87	68.6	2.70	25.2	0.99
<b>4S20FH20</b>	-20	31	-20	54.0	2.13	123.3	4.85	68.1	2.68	25.2	0.99
<b>4S24FH20</b>	-24	31	-20	63.5	2.50	129.0	5.08	73.9	2.91	25.2	0.99
<b>4S24FH24</b>	-24	38	-24	63.5	2.50	189.6	7.46	111.6	4.39	31.1	1.22
<b>4S32FH24</b>	-32	38	-24	79.4	3.13	204.4	8.05	126.4	4.89	31.1	1.22
<b>4S32FH32</b>	-32	51	-32	79.4	3.13	202.7	7.98	124.7	4.91	42.1	1.66
<b>3</b> 6S part #	Terminal End	Hose Size		Flange Head Dia. K Ø		A		D		E Ø	
		mm	in	mm	in	mm	in	mm	in	mm	in
<b>6S16FH16</b>	-16	25	-16	47.7	1.88	98.9	3.89	59.1	2.33	19.2	0.76
<b>6S20FH16</b>	-20	25	-16	54.0	2.13	100.8	3.97	61.0	2.40	19.2	0.76
<b>6S20FH20</b>	-20	31	-20	54.0	2.13	124.0	4.88	68.1	2.68	25.2	0.99
<b>6S24FH20</b>	-24	31	-20	63.5	2.50	129.8	5.11	73.9	2.91	25.2	0.99
<b>6S24FH24</b>	-24	38	-24	63.5	2.50	189.6	7.46	111.6	4.39	31.1	1.22
<b>6S32FH24</b>	-32	38	-24	79.4	3.13	204.4	8.05	126.4	4.98	31.1	1.22
<b>6S32FH32</b>	-32	51	-32	79.4	3.13	202.7	7.98	124.7	4.91	42.1	1.66

## Spiral - 1T/4S &amp; 6S Series

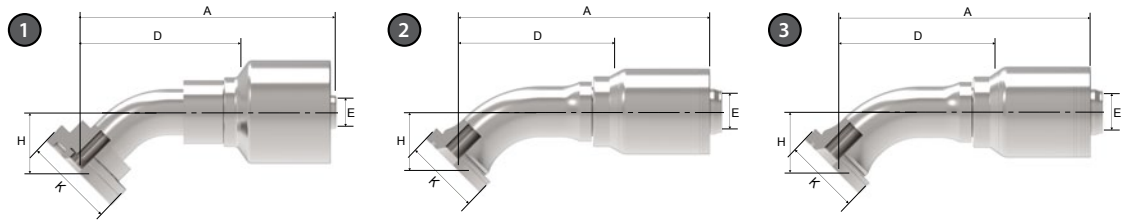

# FHA

SAE CODE 62 Flange - 45° Elbow (FHA)

**1T**
**4S**
**6S**

PART		HOSE SIZE INFO				DIMENSIONS							
1 1T part #	Terminal End	Hose Size		Flange Head Dia. K Ø		A		D		E Ø		H	
		DN	Dash Size	mm	in	mm	in	mm	in	mm	in	mm	in
<b>1T8FHA8</b>	-08	12	-08	31.8	1.25	90.1	3.55	57.1	2.25	9.0	0.35	21.3	0.84
<b>1T12FHA8</b>	-12	12	-08	41.3	1.62	92.8	3.66	59.8	2.36	9.0	0.35	23.9	0.94
<b>1T8FHA10</b>	-8	16	-10	31.8	1.25	94.1	3.71	57.5	2.27	12.0	0.47	21.3	0.84
<b>1T12FHA10</b>	-12	16	-10	41.3	1.62	101.0	3.98	64.4	2.54	12.0	0.47	25.7	1.01
2 4S part #	Terminal End	Hose Size		Flange Head Dia. K Ø		A		D		E Ø		H	
		DN	Dash Size	mm	in	mm	in	mm	in	mm	in	mm	in
<b>4S12FHA12</b>	-12	19	-12	41.3	1.63	113.8	4.48	77.6	3.06	14.2	0.56	27.0	1.06
<b>4S16FHA12</b>	-16	19	-12	47.7	1.88	128.0	5.04	91.7	3.61	14.2	0.56	32.0	1.26
<b>4S12FHA16</b>	-12	25	-16	41.3	1.63	116.9	4.60	77.2	3.04	15.1	0.59	27.0	1.06
<b>4S16FHA16</b>	-16	25	-16	47.7	1.88	130.9	5.15	91.2	3.59	19.2	0.76	32.0	1.26
<b>4S20FHA16</b>	-20	25	-16	54.0	2.13	150.2	5.91	110.5	4.35	19.2	0.76	39.0	1.54
<b>4S20FHA20</b>	-20	31	-20	54.0	2.13	166.6	6.56	111.6	4.39	25.2	0.99	39.0	1.54
<b>4S24FHA20</b>	-24	31	-20	63.5	2.50	183.2	7.21	128.2	5.05	25.2	0.99	45.0	1.77
<b>4S24FHA24</b>	-24	38	-24	63.5	2.50	214.1	8.43	136.1	5.36	31.1	1.22	45.0	1.77
<b>4S32FHA24</b>	-32	38	-24	79.4	3.13	251.0	9.88	173.0	6.81	31.1	1.22	57.5	2.26
<b>4S32FHA32</b>	-32	51	-32	79.4	3.13	253.9	10.00	175.9	6.93	42.1	1.66	57.5	2.26
3 6S part #	Terminal End	Hose Size		Flange Head Dia. K Ø		A		D		E Ø		H	
		DN	Dash Size	mm	in	mm	in	mm	in	mm	in	mm	in
<b>6S16FHA16</b>	-16	25	-16	47.7	1.88	130.9	5.15	91.2	3.59	19.2	0.76	32.0	1.26
<b>6S20FHA16</b>	-20	25	-16	54.0	2.13	150.2	5.91	110.5	4.35	19.0	0.75	39.0	1.54
<b>6S20FHA20</b>	-20	31	-20	54.0	2.13	167.6	6.60	111.6	4.39	25.2	0.99	39.0	1.54
<b>6S24FHA20</b>	-24	31	-20	63.5	2.50	184.2	7.25	128.2	5.05	25.2	0.99	45.0	1.77
<b>6S24FHA24</b>	-24	38	-24	63.5	2.50	214.1	8.43	136.1	5.36	31.1	1.22	45.0	1.77
<b>6S32FHA24</b>	-32	38	-24	79.4	3.13	251.0	9.88	173.0	6.81	31.1	1.22	57.5	2.26
<b>6S32FHA32</b>	-32	51	-32	79.4	3.13	253.9	10.00	175.9	6.93	42.1	1.66	57.5	2.26

# FHB

SAE CODE 62 Flange - 90° Elbow (FHB)

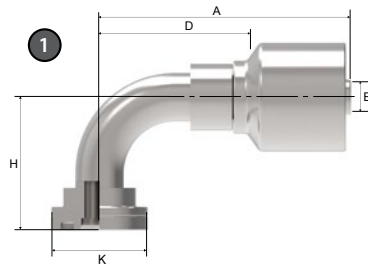
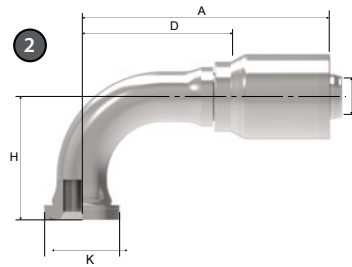
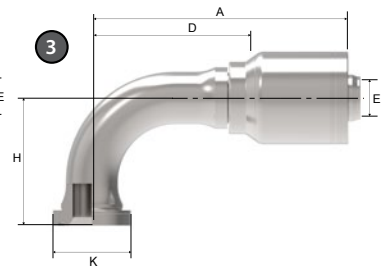
**1T**

**4S**

**6S**

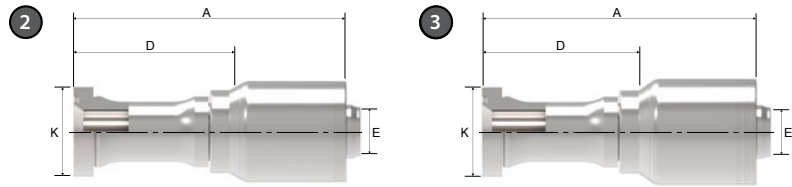
PART		HOSE SIZE INFO				DIMENSIONS							
① 1T part #	Termi- nal End	Hose Size		Flange Head Dia. K Ø		A		D		E Ø		H	
		DN	Dash Size	mm	in	mm	in	mm	in	mm	in	mm	in
<b>1T8FHB8</b>	-08	12	-08	31.8	1.25	83.5	3.29	50.5	1.99	9.0	0.35	44.7	1.76
<b>1T12FHB8</b>	-12	12	-08	41.3	1.62	83.5	3.29	50.5	1.99	9.0	0.35	78.0	3.07
<b>1T8FHB10</b>	-8	16	-10	31.8	1.25	87.5	3.45	50.9	2.01	12.0	0.47	44.7	1.76
<b>1T12FHB10</b>	-12	16	-10	41.3	1.62	93.3	3.67	56.7	2.23	12.0	0.47	54.3	2.14
② 4S part #	Termi- nal End	Hose Size		Flange Head Dia. K Ø		A		D		E Ø		H	
		DN	Dash Size	mm	in	mm	in	mm	in	mm	in	mm	in
<b>4S12FHB12</b>	-12	19	-12	41.3	1.63	108.5	4.27	72.3	2.85	14.2	0.56	59.0	2.32
<b>4S16FHB12</b>	-16	19	-12	47.7	1.88	122.9	4.84	86.6	3.41	14.2	0.56	71.0	2.80
<b>4S16FHB16</b>	-16	25	-16	47.7	1.88	125.5	4.94	86.1	3.39	19.2	0.76	71.0	2.80
<b>4S16FHB16.120</b>	-16	25	-16	47.7	1.88	126.0	4.96	86.2	3.39	19.2	0.76	120.0	4.72
<b>4S20FHB16</b>	-20	25	-16	54.0	2.13	145.3	5.72	105.4	4.15	19.2	0.76	89.0	3.50
<b>4S16FHB20</b>	-16	31	-20	47.7	1.88	147.1	5.79	91.9	3.62	25.2	0.99	71.0	2.80
<b>4S20FHB20</b>	-20	31	-20	54.0	2.13	161.5	6.36	106.5	4.19	25.2	0.99	89.0	3.50
<b>4S20FHB20.120</b>	-20	31	-20	54.0	2.13	161.5	6.36	106.5	4.19	25.2	0.99	120.0	4.72
<b>4S24FHB20</b>	-24	31	-20	63.5	2.50	178.0	7.01	123.0	4.84	25.2	0.99	104.0	4.09
<b>4S24FHB24</b>	-24	38	-24	63.5	2.50	208.9	8.22	130.8	5.15	31.1	1.22	104.0	4.09
<b>4S32FHB24</b>	-32	38	-24	79.4	3.13	247.4	9.74	169.4	6.67	31.1	1.22	138.0	5.43
<b>4S32FHB32</b>	-32	51	-32	79.4	3.13	250.3	9.85	172.2	6.78	42.1	1.66	138.0	5.43
③ 6S part #	Termi- nal End	Hose Size		Flange Head Dia. K Ø		A		D		E Ø		H	
		DN	Dash Size	mm	in	mm	in	mm	in	mm	in	mm	in
<b>6S16FHB16</b>	-16	25	-16	47.7	1.88	125.5	4.94	86.1	3.39	19.2	0.76	71.0	2.80
<b>6S20FHB16</b>	-20	25	-16	54.0	2.13	145.3	5.72	105.4	4.15	19.2	0.76	89.0	3.50
<b>6S16FHB20</b>	-16	31	-20	47.7	1.88	147.9	5.82	91.9	3.62	25.2	0.99	71.0	2.80
<b>6S20FHB20</b>	-20	31	-20	54.0	2.13	162.5	6.40	106.5	4.19	25.2	0.99	89.0	3.50
<b>6S24FHB20</b>	-24	31	-20	63.5	2.50	179.0	7.05	123.0	4.84	25.2	0.99	104.0	4.09
<b>6S24FHB24</b>	-24	38	-24	63.5	2.50	208.9	8.22	130.8	5.15	31.1	1.22	104.0	4.09
<b>6S32FHB24</b>	-32	38	-24	79.4	3.13	247.4	9.74	169.4	6.67	31.1	1.22	138.0	5.43
<b>6S32FHB32</b>	-32	51	-32	79.4	3.13	250.3	9.85	172.2	6.78	42.1	1.66	138.0	5.43

## Spiral - 1T/4S &amp; 6S Series

**4S**
**6S**

# CT

CAT® Flange (CT)

PART	HOSE SIZE INFO					DIMENSIONS					
	Terminal End	Hose Size		Flange Head Dia. K Ø		A		D		E Ø	
<b>2</b> 4S part #		DN	Dash Size	mm	in	mm	in	mm	in	mm	in
<b>4S12CT12</b>	-12	19	-12	41.3	1.63	96.2	3.79	60.0	2.36	14.2	0.56
<b>4S16CT12</b>	-16	19	-12	47.6	1.87	94.9	3.74	58.7	2.31	14.2	0.56
<b>4S16CT16</b>	-16	25	-16	47.6	1.87	102.1	4.02	62.3	2.45	19.2	0.76
<b>4S20CT16</b>	-20	25	-16	54.0	2.13	104.8	4.13	65.0	2.56	19.2	0.76
<b>4S20CT20</b>	-20	31	-20	54.0	2.13	124.5	4.90	69.1	2.72	25.2	0.99
<b>4S24CT20</b>	-24	31	-20	63.5	2.50	130.9	5.15	75.9	2.99	25.2	0.99
<b>4S24CT24</b>	-24	38	-24	63.5	2.50	195.0	7.68	117.0	4.61	31.1	1.22
<b>4S32CT24</b>	-32	38	-24	79.4	3.13	206.0	8.11	128.0	5.04	31.1	1.22
<b>4S32CT32</b>	-32	51	-32	79.4	3.13	208.9	8.22	130.9	5.15	42.1	1.66
<b>3</b> 6S part #		DN	Dash Size	mm	in	mm	in	mm	in	mm	in
<b>6S16CT16</b>	-16	25	-16	47.6	1.87	102.1	4.02	62.3	2.45	19.2	0.76
<b>6S20CT16</b>	-20	25	-16	54.0	2.13	104.8	4.13	65.0	2.56	19.2	0.76
<b>6S20CT20</b>	-20	31	-20	54.0	2.13	125.2	4.93	69.1	2.72	25.2	0.99
<b>6S24CT20</b>	-24	31	-20	63.5	2.50	131.8	5.19	75.9	2.99	25.2	0.99
<b>6S24CT24</b>	-24	38	-24	63.5	2.50	195.0	7.68	117.0	4.61	31.1	1.22
<b>6S32CT24</b>	-32	38	-24	79.4	3.13	206.0	8.11	128.0	5.04	31.1	1.22
<b>6S32CT32</b>	-32	51	-32	79.4	3.13	208.9	8.22	130.9	5.15	42.1	1.66

# CTA

CAT® Flange - 45° Elbow (CTA)

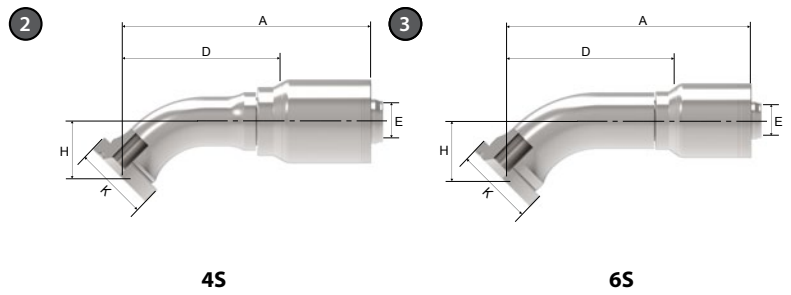
**4S**
**6S**

PART	HOSE SIZE INFO				DIMENSIONS								
② 4S part #	Termi- nal End	Hose Size		Flange Head Dia. K Ø		A		D		E Ø		H	
		DN	Dash Size	mm	in	mm	in	mm	in	mm	in	mm	in
<b>4S12CTA12</b>	-12	19	-12	41.3	1.63	117.7	4.63	81.5	3.21	14.2	0.56	30.9	1.22
<b>4S16CTA12</b>	-16	19	-12	47.6	1.87	131.2	5.17	95.0	3.74	14.2	0.56	35.3	1.39
<b>4S16CTA16</b>	-16	25	-16	47.6	1.87	134.3	5.29	94.6	3.72	19.2	0.76	35.3	1.39
<b>4S20CTA16</b>	-20	25	-16	54.0	2.13	153.0	6.02	113.2	4.46	19.2	0.76	41.8	1.65
<b>4S20CTA20</b>	-20	31	-20	54.0	2.13	169.4	6.67	114.3	4.50	25.2	0.99	41.8	1.65
<b>4S24CTA20</b>	-24	31	-20	63.5	2.50	185.3	7.30	129.1	5.08	25.2	0.99	46.2	1.82
<b>4S24CTA24</b>	-24	38	-24	63.5	2.50	215.2	8.47	137.2	5.40	31.1	1.22	46.2	1.82
<b>4S32CTA32</b>	-32	51	-32	79.4	3.13	255.1	10.04	177.0	6.97	42.1	1.66	58.7	1.31
③ 6S part #	Termi- nal End	Hose Size		Flange Head Dia. K Ø		A		D		E Ø		H	
		DN	Dash Size	mm	in	mm	in	mm	in	mm	in	mm	in
<b>6S16CTA16</b>	-16	25	-16	47.6	1.87	134.3	5.29	94.6	3.72	19.2	0.76	35.3	1.39
<b>6S20CTA16</b>	-20	25	-16	54.0	2.13	153.0	6.02	113.2	4.46	19.2	0.76	41.8	1.65
<b>6S20CTA20</b>	-20	31	-20	54.0	2.13	170.3	6.70	114.3	4.50	25.2	0.99	41.8	1.65
<b>6S24CTA20</b>	-24	31	-20	63.5	2.50	185.3	7.30	129.1	5.08	25.2	0.99	46.2	1.82
<b>6S24CTA24</b>	-24	38	-24	63.5	2.50	215.2	8.47	137.2	5.40	31.1	1.22	46.2	1.82
<b>6S32CTA24</b>	-32	38	-24	79.4	3.13	252.2	9.93	174.2	6.86	31.1	1.22	58.7	2.31
<b>6S32CTA32</b>	-32	51	-32	79.4	3.13	255.1	10.04	177.0	6.97	42.1	1.66	58.7	2.31



## Spiral - 1T/4S &amp; 6S Series

# CTB

CAT® Flange - 90° Elbow (CTB)

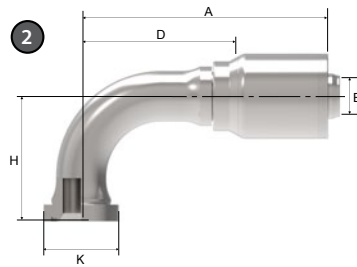
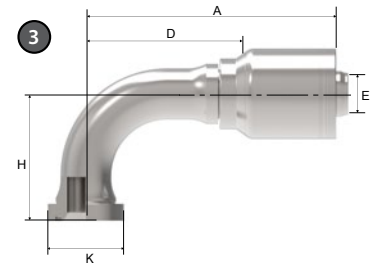
**4S**

**6S**

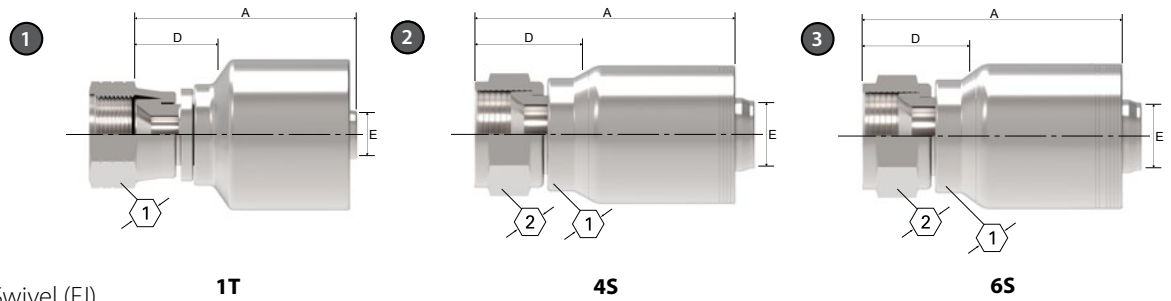
PART	HOSE SIZE INFO					DIMENSIONS							
	Terminal End	Hose Size		Flange Head Dia. K Ø		A		D		E Ø		H	
② 4S part #		DN	Dash Size	mm	in	mm	in	mm	in	mm	in	mm	in
<b>4S12CTB12</b>	-12	19	-12	41.3	1.63	108.5	4.27	72.3	2.85	14.2	0.56	64.5	2.54
<b>4S16CTB12</b>	-16	19	-12	47.6	1.87	122.8	4.83	86.6	3.41	14.2	0.56	75.7	2.98
<b>4S16CTB16</b>	-16	25	-16	47.6	1.87	126.0	4.96	86.2	3.39	19.2	0.76	75.7	2.98
<b>4S20CTB16</b>	-20	25	-16	54.0	2.13	145.2	5.72	105.4	4.15	19.2	0.76	92.9	3.66
<b>4S20CTB20</b>	-20	31	-20	54.0	2.13	161.5	6.36	106.5	4.19	25.2	0.99	92.9	3.66
<b>4S24CTB20</b>	-24	31	-20	63.5	2.50	178.0	7.01	123.0	4.84	25.2	0.99	105.6	4.16
<b>4S24CTB24</b>	-24	38	-24	63.5	2.50	208.9	8.22	130.9	5.15	31.1	1.22	105.7	4.16
<b>4S32CTB32</b>	-32	51	-32	79.4	3.13	250.3	9.85	172.2	6.78	42.1	1.66	139.7	5.50
③ 6S part #		Hose Size		Flange Head Dia. K Ø		A		D		E Ø		H	
<b>6S16CTB16</b>	-16	25	-16	47.6	1.87	126.0	4.96	86.2	3.39	19.2	0.76	75.7	2.98
<b>6S20CTB16</b>	-20	25	-16	54.0	2.13	145.2	5.72	105.4	4.15	19.2	0.76	92.9	3.66
<b>6S20CTB20</b>	-20	31	-20	54.0	2.13	162.5	6.40	106.5	4.19	25.2	0.99	92.9	3.66
<b>6S24CTB20</b>	-24	31	-20	63.5	2.50	179.0	7.05	123.0	4.84	25.2	0.99	105.6	4.16
<b>6S24CTB24</b>	-24	38	-24	63.5	2.50	208.9	8.22	130.9	5.15	31.1	1.22	105.7	4.16
<b>6S32CTB24</b>	-32	38	-24	79.4	3.13	247.4	9.74	169.4	6.67	31.1	1.22	139.7	5.50
<b>6S32CTB32</b>	-32	51	-32	79.4	3.13	250.3	9.85	172.2	6.78	42.1	1.66	139.7	5.50



# FJ

JIC 37° Female Swivel (FJ)

**1T**
**4S**
**6S**

PART	HOSE SIZE INFO				DIMENSIONS							
	Terminal End	Hose Size		Thread	A		D		E Ø		1	
1T Part #		DN	Dash Size		mm	in	mm	in	mm	in	mm	in
<b>1T6FJ6</b>	-06	10	-06	9/16" - 18	47.0	1.85	17.5	0.69	6.5	0.26	17	0.67
<b>1T8FJ6</b>	-08	10	-06	3/4" - 16	49.0	1.93	19.0	0.75	6.5	0.26	22	0.87
<b>1T8FJ8</b>	-08	12	-08	3/4" - 16	52.5	2.07	19.5	0.77	9.1	0.36	22	0.87
<b>1T10FJ8</b>	-10	12	-08	7/8" - 14	54.0	2.13	21.0	0.83	9.0	0.35	27	1.06
<b>1T10FJ10</b>	-10	16	-10	7/8" - 14	59.5	2.34	22.9	0.90	12.0	0.47	27	1.06
<b>1T12FJ10</b>	-12	16	-10	1 1/16" - 12	57.0	2.25	20.0	0.79	12.0	0.47	32	1.26

PART	HOSE SIZE INFO				DIMENSIONS									
	Terminal End	Hose Size		Thread	A		D		E Ø		1		2	
4S Part #		DN	Dash Size		mm	in	mm	in	mm	in	mm	in	mm	in
<b>4S10FJ12</b>	-10	19	-12	7/8" - 14	75.0	2.95	38.8	1.53	12.3	0.48	30	1.18	27	1.06
<b>4S12FJ12</b>	-12	19	-12	1 1/16" - 12	82.0	3.23	45.7	1.80	14.2	0.56	30	1.18	32	1.26
<b>4S14FJ12</b>	-14	19	-12	1 3/16" - 12	79.2	3.12	43.0	1.69	14.2	0.56	30	1.18	36	1.42
<b>4S16FJ12</b>	-16	19	-12	1 5/16" - 12	80.2	3.16	44.0	1.73	14.2	0.56	30	1.18	41	1.61
<b>4S12FJ16</b>	-12	25	-16	1 1/16" - 12	79.0	3.11	39.1	1.54	15.5	0.61	41	1.61	32	1.26
<b>4S16FJ16</b>	-16	25	-16	1 5/16" - 12	89.2	3.51	49.3	1.94	19.2	0.76	41	1.61	41	1.61
<b>4S20FJ16</b>	-20	25	-16	1 5/8" - 12	85.8	3.38	46.0	1.81	19.2	0.76	41	1.61	50	1.97
<b>4S16FJ20</b>	-16	31	-20	1 5/16" - 12	99.1	3.90	43.7	1.72	25.2	0.99	46	1.81	41	1.61
<b>4S20FJ20</b>	-20	31	-20	1 5/8" - 12	101.6	4.00	46.3	1.82	25.2	0.99	46	1.81	50	1.97
<b>4S24FJ20</b>	-24	31	-20	1 7/8" - 12	106.8	4.20	51.5	2.03	25.2	0.99	46	1.81	55	2.17
<b>4S24FJ24</b>	-24	38	-24	1 7/8" - 12	134.9	5.31	56.8	2.24	31.1	1.22	-	-	55	2.17
<b>4S32FJ32</b>	-32	51	-32	2 1/2" - 12	146.0	5.75	68.0	2.68	42.1	1.66	-	-	75	2.95

PART	HOSE SIZE INFO				DIMENSIONS									
	Terminal End	Hose Size		Thread	A		D		E Ø		1		2	
6S Part #		DN	Dash Size		mm	in	mm	in	mm	in	mm	in	mm	in
<b>6S16FJ16</b>	-16	25	-16	1 5/16" - 12	89.2	3.51	49.3	1.94	19.2	0.76	41	1.61	41	1.61
<b>6S20FJ20</b>	-20	31	-20	1 5/8" - 12	102.4	4.03	46.4	1.83	25.2	0.99	46	1.81	50	1.97
<b>6S24FJ20</b>	-24	31	-20	1 7/8" - 12	107.5	4.23	51.5	2.03	25.2	0.99	46	1.81	55	2.17
<b>6S24FJ24</b>	-24	38	-24	1 7/8" - 12	134.9	5.31	56.8	2.24	31.1	1.22	57	2.24	55	2.17
<b>6S32FJ32</b>	-32	51	-32	2 1/2" - 12	146.0	5.75	68.0	2.68	42.1	1.66	-	-	75	2.95

⚠ When assembled with all Danfoss components, all SAE 37° JIC male and female terminal ends in the 4S & 6S product line are rated at the pressures listed in the table above and have passed one million impulse cycles at 133% of this pressure. All straight configurations achieve a 4:1 burst. The 45° and 90° elbow configurations in the -12 size meet a 3.2:1 burst the 45° and 90° elbow configurations in the -16 size achieve a 2.8:1 burst; the 45° and 90° elbow configurations in the -20 size meet a 4:1 burst and the 45° & 90° elbow configurations in the -24 size meet a 2.4:1 burst.

## Spiral - 1T/4S &amp; 6S Series

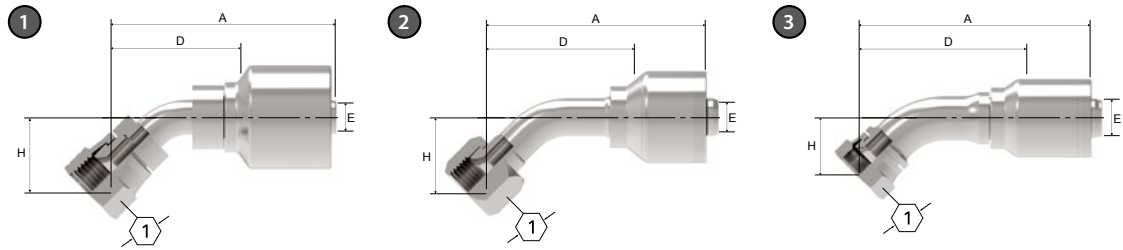

# FJA

JIC 37° Female Swivel - 45° Elbow (FJA)

**1T**
**4S**
**6S**

PART		HOSE SIZE INFO			DIMENSIONS									
1 1T part #	Termi- nal End	Hose Size		Thread	A		D		E Ø		H		1	
		DN	Dash Size		mm	in	mm	in	mm	in	mm	in	mm	in
<b>1T6FJA6</b>	-06	10	-06	9/16" - 18	64.9	2.56	35.4	1.39	6.6	0.26	13.4	0.53	17	0.67
<b>1T8FJA8</b>	-08	12	-08	3/4" - 16	78.2	3.08	45.2	1.78	9.0	0.35	19.7	0.78	22	0.87
<b>1T10FJA10</b>	-10	16	-10	7/8" - 14	97.0	3.82	60.0	2.36	12.0	0.47	24.5	0.97	27	1.06
2 4S part #	Termi- nal End	Hose Size		Thread	A		D		E Ø		H		1	
		mm	in		mm	in	mm	in	mm	in	mm	in	mm	in
<b>4S12FJA12</b>	-12	19	-12	1 1/16" - 12	112.3	4.42	76.1	3.00	14.2	0.56	29.0	1.14	32	1.26
<b>4S16FJA12</b>	-16	19	-12	1 5/16" - 12	133.6	5.26	97.5	3.84	14.2	0.56	38.0	1.50	41	1.61
<b>4S16FJA16</b>	-16	25	-16	1 5/16" - 12	128.8	5.07	89.3	3.52	19.2	0.76	38.0	1.50	41	1.61
<b>4S20FJA16</b>	-20	25	-16	1 5/8" - 12	120.1	4.73	80.4	3.17	19.2	0.75	32.0	1.26	50	1.97
<b>4S20FJA20</b>	-20	31	-20	1 5/8" - 12	135.6	5.34	80.4	3.17	25.2	0.99	32.0	1.26	50	1.97
<b>4S24FJA24</b>	-24	38	-24	1 7/8" - 12	212.0	8.35	134.0	5.28	31.1	1.22	43.0	1.69	55	2.16
3 6S part #	Termi- nal End	Hose Size		Thread	A		D		E Ø		H		1	
		mm	in		mm	in	mm	in	mm	in	mm	in	mm	in
<b>6S20FJA20</b>	-20	31	-20	1 5/8" - 12	136.4	5.37	80.4	3.17	25.2	0.99	32.0	1.26	50	1.97
<b>6S24FJA24</b>	-24	38	-24	1 7/8" - 12	212.0	8.35	134.0	5.28	31.1	1.22	43.0	1.69	55	2.16

! When assembled with all Danfoss components, all SAE 37° JIC male and female terminal ends in the 4S & 6S product line are rated at the pressures listed in the table above and have passed one million impulse cycles at 133% of this pressure. All straight configurations achieve a 4:1 burst. The 45° and 90° elbow configurations in the -12 size meet a 3.2:1 burst the 45° and 90° elbow configurations in the -16 size achieve a 2.8:1 burst; the 45° and 90° elbow configurations in the -20 size meet a 4:1 burst and the 45° & 90° elbow configurations in the -24 size meet a 2.4:1 burst.

# FJB

JIC 37° Female Swivel - 90° Elbow (FJB)

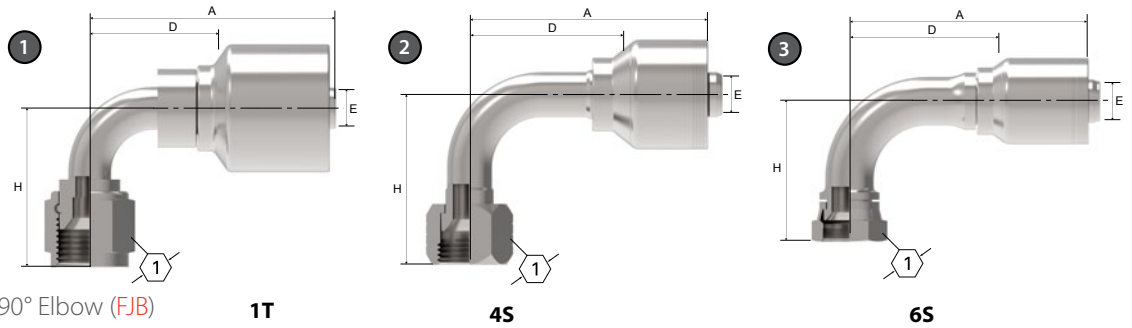

PART	HOSE SIZE INFO			DIMENSIONS										
	Terminal End	Hose Size		Thread	A		D		E Ø		H		1	
1T part #		DN	Dash Size		mm	in	mm	in	mm	in	mm	in	mm	in
<b>1T6FJB6</b>	-06	10	-06	9/16" - 18	58.8	2.31	29.3	1.15	6.6	0.26	26.3	1.04	17	0.67
<b>1T8FJB8</b>	-08	12	-08	3/4" - 16	69.0	2.72	36	1.42	9.0	0.35	34.0	1.34	22	0.87
<b>1T10FJB10</b>	-10	16	-10	7/8" - 14	87.0	3.43	46.4	1.83	12.0	0.47	49.0	1.93	27	1.06
<b>2</b> 4S part #	Terminal End	Hose Size		Thread	A		D		E Ø		H		1	
<b>4S12FJB12</b>	-12	19	-12	1 1/16" - 12	101.3	3.99	65.3	2.57	14.2	0.56	58.0	2.28	32	1.26
<b>4S16FJB12</b>	-16	19	-12	1 5/16" - 12	110.0	4.33	73.8	2.91	14.2	0.56	71.0	2.80	41	1.61
<b>4S16FJB16</b>	-16	25	-16	1 5/16" - 12	113.1	4.45	73.5	2.89	19.2	0.76	71.0	2.80	41	1.61
<b>4S20FJB16</b>	-20	25	-16	1 5/8" - 12	117.1	4.61	77.4	3.05	19.2	0.75	78.0	3.07	50	1.97
<b>4S20FJB20</b>	-20	31	-20	1 5/8" - 12	132.6	5.22	77.4	3.05	25.2	0.99	78.0	3.07	50	1.97
<b>4S24FJB24</b>	-24	38	-24	1 7/8" - 12	208.9	8.22	130.8	5.15	31.1	1.22	104.0	4.09	55	2.16
<b>3</b> 6S part #	Terminal End	Hose Size		Thread	A		D		E Ø		H		1	
<b>6S16FJB16</b>	-16	25	-16	1 5/16" - 12	113.1	4.45	73.5	2.89	19.0	0.75	71.0	2.80	41	1.61
<b>6S20FJB20</b>	-20	31	-20	1 5/8" - 12	133.4	5.25	77.4	3.05	25.2	0.99	78.0	3.07	50	1.97
<b>6S24FJB24</b>	-24	38	-24	1 7/8" - 12	208.9	8.22	130.8	5.15	31.1	1.22	104.0	4.09	55	2.16

! When assembled with all Danfoss components, all SAE 37° JIC male and female terminal ends in the 4S & 6S product line are rated at the pressures listed in the table above and have passed one million impulse cycles at 133% of this pressure. All straight configurations achieve a 4:1 burst. The 45° and 90° elbow configurations in the -12 size meet a 3.2:1 burst the 45° and 90° elbow configurations in the -16 size achieve a 2.8:1 burst; the 45° and 90° elbow configurations in the -20 size meet a 4:1 burst and the 45° & 90° elbow configurations in the -24 size meet a 2.4:1 burst.

## Spiral - 1T/4S &amp; 6S Series

# FR

ORS Female Swivel (FR)

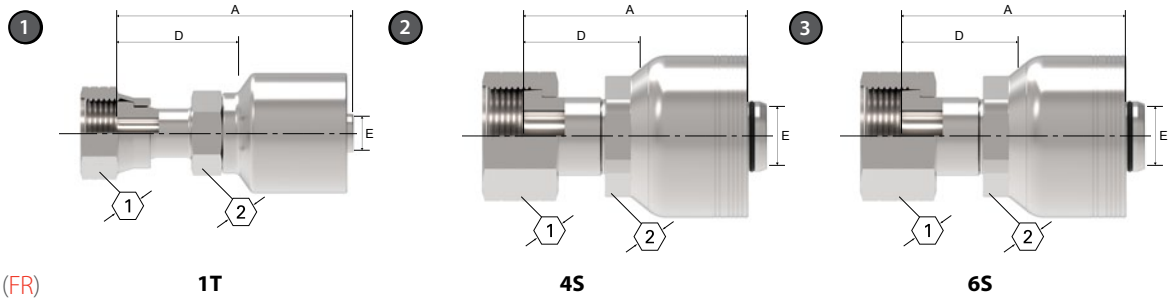

PART		HOSE SIZE INFO			DIMENSIONS									
1 1T part #	Termi- nal End	Hose Size		Thread	A		D		E Ø		2		1	
		DN	Dash Size		mm	in	mm	in	mm	in	mm	in	mm	in
<b>1T6FR6</b>	-06	10	-06	1 1/16" - 16	60.5	2.38	31.0	1.22	6.5	0.26	19	0.75	22	0.87
<b>1T8FR8</b>	-08	12	-08	1 3/16" - 16	70.5	2.78	37.5	1.48	9.0	0.35	22	0.87	24	0.94
<b>1T10FR10</b>	-10	16	-10	1" - 14	75.5	2.97	38.9	1.53	12.0	0.47	27	1.06	30	1.18
2 4S part #	Termi- nal End	Hose Size		Thread	A		D		E Ø		2		1	
		DN	Dash Size		mm	in	mm	in	mm	in	mm	in	mm	in
<b>4S10FR12</b>	-10	19	-12	1" - 14	74.4	2.93	38.1	1.50	14.2	0.56	30	1.18	30	1.18
<b>4S12FR12</b>	-12	19	-12	1 3/16" - 12	77.4	3.05	41.2	1.62	14.2	0.56	30	1.18	36	1.42
<b>4S16FR12</b>	-16	19	-12	1 7/16" - 12	79.2	3.12	43.1	1.70	14.2	0.56	30	1.18	41	1.61
<b>4S12FR16</b>	-12	25	-16	1 3/16" - 12	80.5	3.17	40.8	1.61	19.2	0.76	41	1.61	36	1.42
<b>4S16FR16</b>	-16	25	-16	1 7/16" - 12	82.4	3.24	42.6	1.68	19.2	0.76	41	1.61	41	1.61
<b>4S20FR16</b>	-20	25	-16	1 11/16" - 12	82.4	3.24	42.7	1.68	19.2	0.76	41	1.61	50	1.97
<b>4S20FR20</b>	-20	31	-20	1 11/16" - 12	99.0	3.90	43.8	1.72	25.2	0.99	46	1.81	50	1.97
<b>4S24FR24</b>	-24	38	-24	2" - 12	125.7	4.95	47.6	1.87	31.1	1.22	57	2.24	55	2.17
3 6S part #	Termi- nal End	Hose Size		Thread	A		D		E Ø		2		1	
		DN	Dash Size		mm	in	mm	in	mm	in	mm	in	mm	in
<b>6S16FR16</b>	-16	25	-16	1 7/16" - 12	82.4	3.24	42.6	1.68	19.2	0.76	41	1.61	41	1.61
<b>6S20FR16</b>	-20	25	-16	1 11/16" - 12	82.4	3.24	42.7	1.68	19.2	0.76	41	1.61	50	1.97
<b>6S20FR20</b>	-20	31	-20	1 11/16" - 12	99.8	3.93	43.8	1.72	25.2	0.99	46	1.81	50	1.97
<b>6S24FR24</b>	-24	38	-24	2" - 12	125.7	4.95	47.6	1.87	31.1	1.22	57	2.24	55	2.17

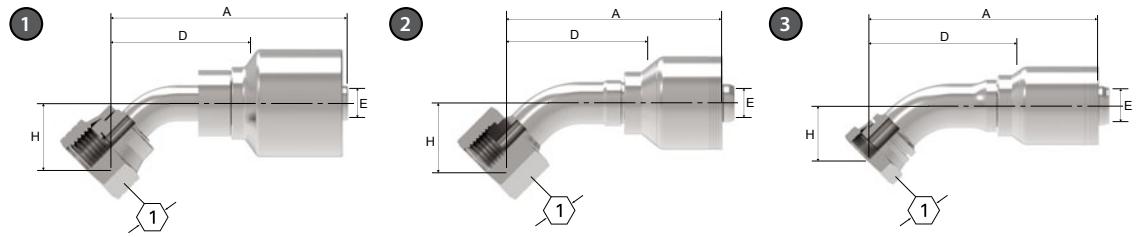

# FRA

ORS Female Swivel - 45° Elbow (FRA)

**1T**
**4S**
**6S**

PART	HOSE SIZE INFO				DIMENSIONS									
	Terminal End	Hose Size		Thread	A		D		E Ø		H		1	
1T part #		DN	Dash Size		mm	in	mm	in	mm	in	mm	in	mm	in
<b>1T6FRA6</b>	-06	10	-06	1 1/16" - 16	65.3	2.57	35.8	1.41	6.6	0.26	10.9	0.43	22	0.87
<b>1T8FRA8</b>	-08	12	-08	1 3/16" - 16	79.1	3.11	46.1	1.81	9.1	0.36	15.0	0.59	24	0.94
<b>1T10FRA10</b>	-10	16	-10	1" - 14	87.4	3.44	50.8	2.00	12.1	0.48	17.4	0.69	30	1.18
<b>2</b> 4S part #	Terminal End	Hose Size		Thread	A		D		E Ø		H		1	
<b>4S12FRA12</b>	-12	19	-12	1 3/16" - 12	108.7	4.28	72.5	2.85	14.2	0.56	24.0	0.94	36	1.42
<b>4S16FRA12</b>	-16	19	-12	1 7/16" - 12	119.9	4.72	83.7	3.30	14.2	0.56	24.0	0.94	41	1.61
<b>4S16FRA16</b>	-16	25	-16	1 7/16" - 12	112.8	4.44	73.0	2.87	19.2	0.76	28.0	1.10	41	1.61
<b>4S20FRA16</b>	-20	25	-16	1 11/16" - 12	136.7	5.38	97.0	3.82	19.2	0.76	31.0	1.22	50	1.97
<b>4S20FRA20</b>	-20	31	-20	1 11/16" - 12	153.4	6.04	98.1	3.86	25.2	0.99	31.0	1.22	50	1.97
<b>4S24FRA24</b>	-24	38	-24	2" - 12	212.0	8.35	134.0	5.28	31.1	1.22	43.0	1.69	55	2.17
<b>3</b> 6S part #	Terminal End	Hose Size		Thread	A		D		E Ø		H		1	
<b>6S16FRA16</b>	-16	25	-16	1 7/16" - 12	112.8	4.44	73.0	2.87	19.2	0.76	28.0	1.10	41	1.61
<b>6S20FRA16</b>	-20	25	-16	1 11/16" - 12	136.7	5.38	97.0	3.82	19.2	0.76	31.0	1.22	50	1.97
<b>6S20FRA20</b>	-20	31	-20	1 11/16" - 12	154.1	6.07	98.1	3.86	25.2	0.99	31.0	1.22	50	1.97
<b>6S24FRA24</b>	-24	38	-24	2" - 12	212.0	8.35	134.0	5.28	31.1	1.22	43.0	1.69	55	2.17

## Spiral - 1T/4S &amp; 6S Series

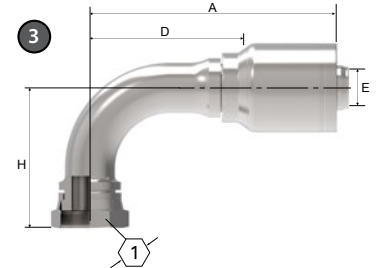
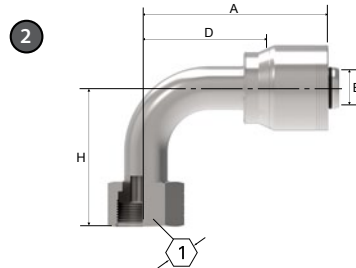
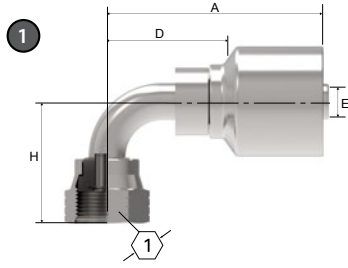

# FRB

ORS Female Swivel - 90° Elbow (FRB)

**1T**
**4S**
**6S**

PART	HOSE SIZE INFO				DIMENSIONS									
	Terminal End	Hose Size		Thread	A		D		E Ø		H		1	
1T part #		DN	Dash Size		mm	in	mm	in	mm	in	mm	in	mm	in
<b>1T6FRB6</b>	-06	10	-06	1 1/16" - 16	61.9	2.44	32.4	1.28	6.5	0.26	22.4	0.88	22	0.87
<b>1T8FRB8</b>	-08	12	-08	1 3/16" - 16	71.7	2.82	38.7	1.52	9.0	0.35	29.1	1.15	24	0.94
<b>1T10FRB10</b>	-10	16	-10	1" - 14	79.8	3.14	43.2	1.70	12.1	0.48	34.3	1.35	30	1.18
<b>2</b> 4S part #	Terminal End	Hose Size		Thread	A		D		E Ø		H		1	
<b>4S10FRB12</b>	-10	19	-12	1" - 14	91.5	3.60	55.3	2.18	14.2	0.56	32.3	1.27	30	1.18
<b>4S12FRB12</b>	-12	19	-12	1 3/16" - 12	104.4	4.11	68.1	2.68	14.2	0.56	58.0	2.28	36	1.42
<b>4S16FRB12</b>	-16	19	-12	1 7/16" - 12	117.1	4.61	80.9	3.19	14.2	0.56	71.0	2.80	41	1.61
<b>4S12FRB16</b>	-12	25	-16	1 3/16" - 12	122.5	4.82	68.1	2.68	19.2	0.76	58.0	2.28	36	1.42
<b>4S16FRB16</b>	-16	25	-16	1 7/16" - 12	112.8	4.44	73.0	2.87	19.2	0.76	71.0	2.80	41	1.61
<b>4S20FRB16</b>	-20	25	-16	1 11/16" - 12	136.5	5.37	96.8	3.81	19.2	0.76	78.0	3.07	50	1.97
<b>4S20FRB20</b>	-20	31	-20	1 11/16" - 12	153.1	6.03	97.9	3.85	25.2	0.99	78.0	3.07	50	1.97
<b>4S24FRB20</b>	-24	31	-20	2" - 12	152.9	6.02	97.9	3.85	25.2	0.99	86.0	3.39	55	2.17
<b>4S24FRB24</b>	-24	38	-24	2" - 12	208.9	8.22	130.8	5.15	31.1	1.22	104.0	4.09	55	2.17
<b>3</b> 6S part #	Terminal End	Hose Size		Thread	A		D		E Ø		H		1	
<b>6S16FRB16</b>	-16	25	-16	1 7/16" - 12	112.8	4.44	73.0	2.87	19.2	0.76	71.0	2.80	41	1.61
<b>6S20FRB16</b>	-20	25	-16	1 11/16" - 12	136.5	5.37	96.8	3.81	19.2	0.76	78.0	3.07	50	1.97
<b>6S20FRB20</b>	-20	31	-20	1 11/16" - 12	154.4	6.08	97.9	3.85	25.2	0.99	78.0	3.07	50	1.97
<b>6S24FRB24</b>	-24	38	-24	2" - 12	208.9	8.22	130.8	5.15	31.1	1.22	104.0	4.09	55	2.17

# BP

BSP 60° Cone Male Parallel (BP)

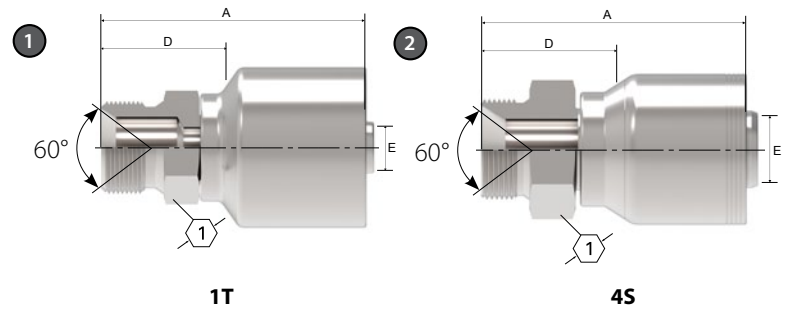

PART		HOSE SIZE INFO			DIMENSIONS							
① 1T part #	Terminal End	Hose Size		Thread	A		D		E Ø		①	
		DN	Dash Size		mm	in	mm	in	mm	in	mm	in
<b>1T6BP6</b>	-06	10	-08	G 3/8"	55.0	2.17	25.5	1.00	6.5	0.26	19	0.75
<b>1T8BP8</b>	-08	12	-08	G 1/2"	61.0	2.40	28.0	1.10	9.0	0.35	22	0.87
<b>1T10BP10</b>	10	16	10	G 5/8"	68.0	2.68	27.4	1.08	12.0	0.47	27	1.06
② 4S part #	Terminal End	Hose Size		Thread	A		D		E Ø		①	
		DN	Dash Size		mm	in	mm	in	mm	in	mm	in
<b>4S12BP12</b>	-12	19	-12	G 3/4" - 14	79.6	3.13	43.4	1.71	14.2	0.56	32	1.26
<b>4S16BP16</b>	-16	25	-16	G 1" - 11	89.8	3.53	50.1	1.97	19.2	0.75	41	1.61
<b>4S20BP20</b>	-20	31	-20	G 1 1/4" - 11	109.7	4.32	54.5	2.15	25.1	0.99	50	1.97

"G" as part of thread size is ISO designation for parallel thread.



## Spiral - 1T/4S &amp; 6S Series

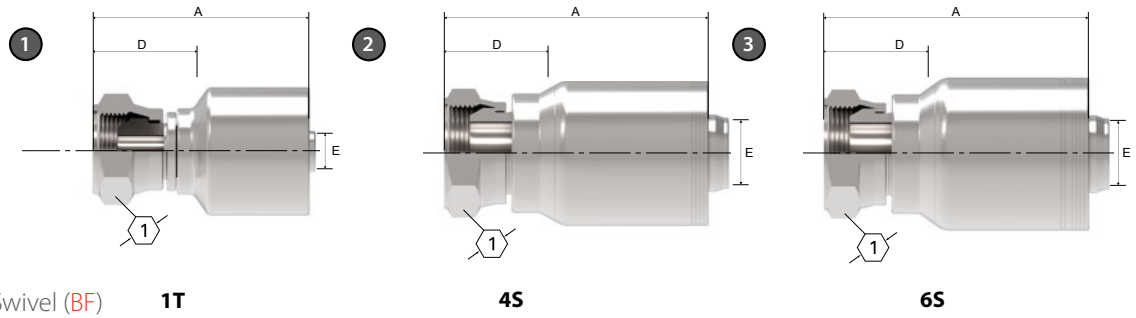

# BP

BSP 60° Cone Female Swivel (BF)

**1T**
**4S**
**6S**

PART		HOSE SIZE INFO			DIMENSIONS							
① 1T part #	Terminal End	Hose Size		Thread	A		D		E Ø		①	
		DN	Dash Size		mm	in	mm	in	mm	in	mm	in
<b>1T6BF6</b>	-06	10	-06	G 3/8"	52.0	2.05	22.5	0.89	6.5	0.26	22	0.87
<b>1T8BF8</b>	-08	12	-08	G 1/2"	55.5	2.19	22.5	0.89	9.0	0.35	27	1.06
<b>1T10BF10</b>	-10	16	-10	G 5/8"	60.0	2.36	23.5	0.93	12.0	0.47	27	1.06
② 4S part #	Terminal End	Hose Size		Thread	A		D		E Ø		①	
		mm	in		mm	in	mm	in	mm	in		
<b>4S12BF12</b>	-12	19	-12	G 3/4"	66.2	2.61	29.9	1.18	14.2	0.56	32	1.26
<b>4S16BF12</b>	-16	19	-12	G 1"	68.7	2.70	32.3	1.27	14.2	0.56	41	1.61
<b>4S16BF16</b>	-16	25	-16	G 1"	71.0	2.80	32.3	1.27	19.2	0.76	41	1.61
<b>4S20BF16</b>	-20	25	-16	G 1 1/4"	72.5	2.85	32.7	1.29	19.2	0.76	50	1.97
<b>4S20BF20</b>	-20	31	-20	G 1 1/4"	82.8	3.26	32.7	1.29	25.2	0.99	50	1.97
<b>4S24BF24</b>	-24	38	-24	G 1 1/2"	117.9	4.64	39.8	1.57	31.1	1.22	55	2.17
<b>4S32BF32</b>	-32	51	-32	G 2"	121.0	4.76	43.0	1.69	42.1	1.66	70	2.76
③ 6S part #	Terminal End	Hose Size		Thread	A		D		E Ø		①	
		mm	in		mm	in	mm	in	mm	in		
<b>6S24BF24</b>	-24	38	-24	G 1 1/2"	117.9	4.64	39.8	1.57	31.1	1.22	55	2.17
<b>6S32BF32</b>	-32	51	-32	G 2"	121.0	4.76	43.0	1.69	42.1	1.66	70	2.76

"G" as part of thread size is ISO designation for parallel thread.

# BFA

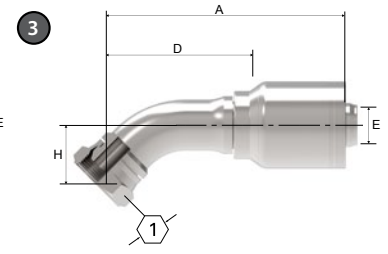
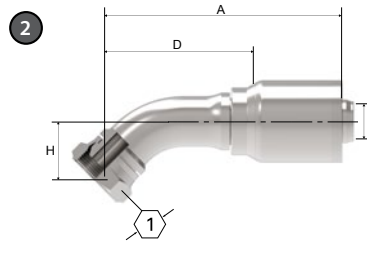
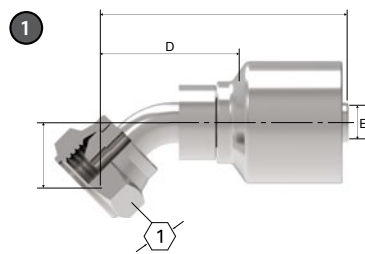
 BSP 60° Cone Female Swivel - 45° Elbow (BFA) **1T**

**4S**
**6S**

PART	HOSE SIZE INFO			DIMENSIONS										
	Terminal End	Hose Size		Thread	A		D		E Ø		H		1	
1T part #		DN	Dash Size		mm	in	mm	in	mm	in	mm	in	mm	in
<b>1T6BFA6</b>	-06	10	-06	G 3/8"	67.9	2.67	38.4	1.51	6.6	0.26	14.0	0.55	22	0.87
<b>1T8BFA8</b>	-08	12	-08	G 1/2"	74.0	2.92	41.0	1.62	9.0	0.35	15.0	0.59	27	1.06
<b>1T10BFA10</b>	-10	16	-10	G 5/8"	80.0	3.15	43.0	1.69	12.0	0.47	16.5	0.65	27	1.06
2	Terminal End	Hose Size		Thread	A		D		E Ø		H		1	
4S part #					mm	in	mm	in	mm	in	mm	in	mm	in
<b>4S12BFA12</b>	-12	19	-12	G 3/4"	112.3	4.42	75.9	2.99	14.2	0.56	26.0	1.02	32	1.26
<b>4S16BFA12</b>	-16	19	-12	G 1"	115.8	4.56	79.5	3.13	14.2	0.56	30.0	1.18	41	1.61
<b>4S16BFA16</b>	-16	25	-16	G 1"	130.3	5.13	90.6	3.57	19.2	0.76	30.0	1.18	41	1.61
<b>4S20BFA16</b>	-20	25	-16	G 1 1/4"	133.0	5.24	93.4	3.68	19.2	0.76	34.0	1.34	50	1.97
<b>4S20BFA20</b>	-20	31	-20	G 1 1/4"	149.5	5.89	99.1	3.90	25.2	0.99	34.0	1.34	50	1.97
<b>4S24BFA24</b>	-24	38	-24	G 1 1/2"	208.3	8.20	130.3	5.13	31.1	1.22	42.4	1.67	55	2.17
<b>4S32BFA32</b>	-32	51	-32	G 2"	248.4	9.78	170.4	6.71	42.1	1.66	54.1	2.13	70	2.76
3	Terminal End	Hose Size		Thread	A		D		E Ø		H		1	
6S part #					mm	in	mm	in	mm	in	mm	in	mm	in
<b>6S24BFA24</b>	-24	38	-24	G 1 1/2"	208.3	8.20	130.3	5.13	31.1	1.22	42.4	1.67	55	2.17
<b>6S32BFA32</b>	-32	51	-32	G 2"	248.4	9.78	170.4	6.71	42.1	1.66	54.1	2.13	70	2.76

"G" as part of thread size is ISO designation for parallel thread.

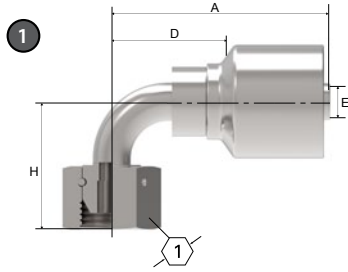
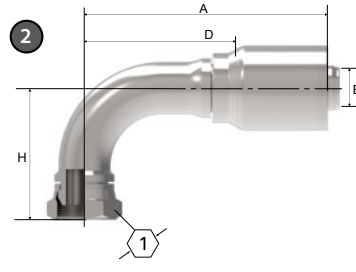
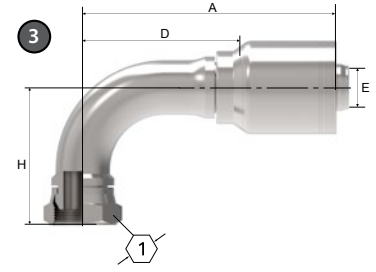
## Spiral - 1T/4S &amp; 6S Series

**1T**

**4S**

**6S**

# BFB

BSP 60° Cone Female Swivel - 90° Elbow (BFB)

PART	HOSE SIZE INFO			DIMENSIONS										
	Terminal End	Hose Size		Thread	A		D		E Ø		H		1	
1T part #		DN	Dash Size		mm	in	mm	in	mm	in	mm	in	mm	in
<b>1T6BFB6</b>	-06	10	-06	G 3/8"	61.9	2.44	32.4	1.28	6.6	0.26	27.7	1.09	22	0.87
<b>1T8BFB8</b>	-08	12	-08	G 1/2"	69.5	2.74	36.5	1.44	9.1	0.36	35.5	1.40	27	1.06
<b>1T10BFB10</b>	-10	16	-10	G 5/8"	76.5	3.01	39.9	1.57	12.0	0.47	36.0	1.42	27	1.06
<b>2</b> 4S part #	Terminal End	Hose Size		Thread	A		D		E Ø		H		1	
<b>4S12BFB12</b>	-12	19	-12	G 3/4"	105.9	4.17	69.6	2.74	14.2	0.56	57.0	2.24	32	1.26
<b>4S16BFB12</b>	-16	19	-12	G 1"	105.9	4.17	69.6	2.74	14.2	0.56	68.0	2.68	41	1.61
<b>4S16BFB16</b>	-16	25	-16	G 1"	125.5	4.94	85.8	3.38	19.2	0.76	68.0	2.68	41	1.61
<b>4S20BFB16</b>	-20	25	-16	G 1 1/4"	125.5	4.94	85.8	3.38	19.2	0.76	79.0	3.11	50	1.97
<b>4S20BFB20</b>	-20	31	-20	G 1 1/4"	145.0	5.71	95.0	3.74	25.2	0.99	79.0	3.11	50	1.97
<b>4S24BFB24</b>	-24	38	-24	G 1 1/2"	205.1	8.07	127.0	5.00	31.1	1.22	98.6	3.88	55	2.17
<b>4S32BFB32</b>	-32	51	-32	G 2"	245.7	9.67	167.6	6.60	42.1	1.66	125.3	4.93	70	2.76
<b>3</b> 6S part #	Terminal End	Hose Size		Thread	A		D		E Ø		H		1	
<b>6S24BFB24</b>	-24	38	-24	G 1 1/2"	205.1	8.07	127.0	5.00	31.1	1.22	98.6	3.88	55	2.17
<b>6S32BFB32</b>	-32	51	-32	G 2"	245.7	9.67	167.6	6.60	42.1	1.66	125.3	4.93	70	2.76

# GC2453

4-Hole Flange SAE J518 C Code 62

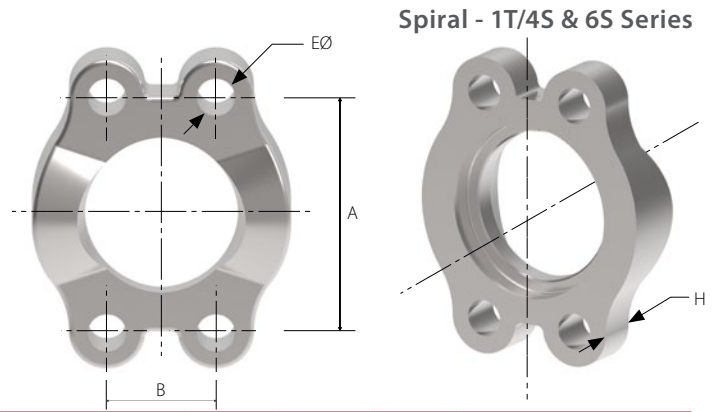

THREAD	HOSE SIZE INFO		DIMENSIONS									
	Thread T	Flange size	Size	Max. Oper. Press	A		B		EØ		H	
			bar	mm	in	mm	in	mm	in	mm	in	
<b>GC2453-8</b>	1/2"	-08	415	40.5	1.59	18.2	0.72	8.4	0.33	16.0	0.63	M8 / 5/16"
<b>GC2453-12</b>	3/4"	-12	415	50.8	2.00	23.8	0.94	10.5	0.41	19.0	0.75	M10 / 3/8"
<b>GC2453-16</b>	1"	-16	415	57.2	2.25	27.8	1.09	12.0	0.47	24.0	0.94	7/16"
<b>GC2453-16.1</b>	1"	-16	415	57.2	2.25	27.8	1.09	13.0	0.51	24.0	0.94	M12
<b>GC2453-20</b>	1 1/4"	-20	415	66.7	2.63	31.8	1.25	13.5	0.53	27.0	1.06	1/2"
<b>GC2453-20.1</b>	1 1/4"	-20	415	66.7	2.63	31.8	1.25	15.0	0.59	27.0	1.06	M14
<b>GC2453-24</b>	1 1/2"	-24	415	79.4	3.13	36.4	1.43	17.0	0.67	30.0	1.18	M16 / 5/8"
<b>GC2453-24HS*</b>	1 1/2"	-24	415	79.4	3.13	36.5	1.44	17.0	0.67	30.0	1.18	M16 / 5/8"
<b>GC2453-32</b>	2"	-32	415	96.8	3.81	44.5	1.75	20.0	0.79	36.5	1.44	3/4"
<b>GC2453-32.1HS*</b>	2"	-32	415	96.8	3.81	44.5	1.75	21.0	0.83	36.5	1.44	M20
<b>GC2453-32.2HS**</b>	2"	-32	415	96.8	3.81	44.5	1.75	21.0	0.83	36.5	1.44	M20

4-hole flanges are an integral part of the end fitting and must be ordered at the same time as the fitting and hose assembly.

\* Colour silver

\*\* Colour gold

## O-Rings

Part number	D Ø (mm)	S Ø (mm)
05.018-210	18.6	3.5
05.018-214	25.0	3.5
05.018-219	32.9	3.5
05.018-219	32.9	3.5
05.018-222	37.7	3.5
05.018-222	37.7	3.5
05.018-225	47.2	3.5
05.018-228	56.7	3.5
05.018-228	56.7	3.5
05.018-228	56.7	3.5

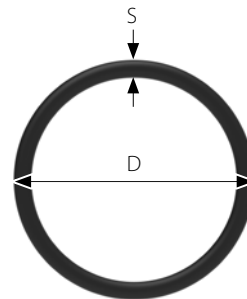

O-Rings have to be ordered separately.

## Spiral - 1T/4S &amp; 6S Series

# G74446

Half Flange SAE J518 C Code 61

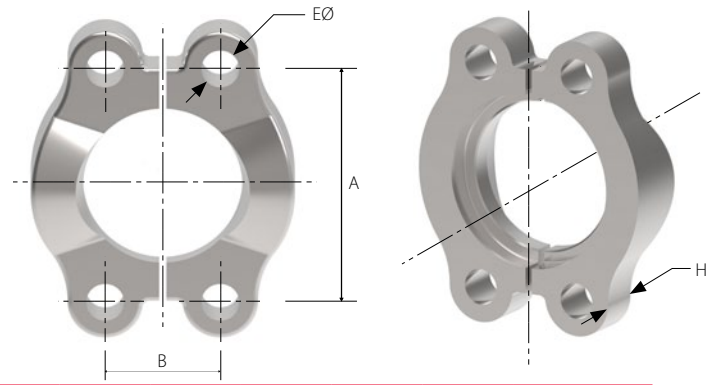

THREAD		HOSE SIZE INFO		DIMENSIONS								
Thread T	Flange size	Size	Max. Oper. Press	A		B		EØ		H		Bolt Ø metric/ inch
			bar	mm	in	mm	in	mm	in	mm	in	
<b>G74446-8</b>	1/2"	-08	345	38.1	1.50	8.7	0.34	8.4	0.33	13.0	0.51	M8 / 5/16"
<b>G74446-12</b>	3/4"	-12	345	47.6	1.87	11.1	0.44	10.5	0.41	14.2	0.56	M10 / 3/8"
<b>G74446-16</b>	1"	-16	345	52.4	2.06	13.1	0.52	10.5	0.41	15.8	0.62	M10 / 3/8"
<b>G74446-20</b>	1 1/4"	20	275	58.7	2.31	15.1	0.59	12.0	0.47	14.2	0.56	7/16"
<b>G74446-20.1</b>	1 1/4"	-20	275	58.7	2.31	15.1	0.59	10.5	0.41	14.2	0.56	M10
<b>G74446-20.2</b>	1 1/4"	-20	275	58.7	2.31	15.1	0.59	12.5	0.49	14.2	0.56	M12 / 1/2"
<b>G74446-24</b>	1 1/2"	-24	210	69.8	2.75	17.8	0.70	13.0	0.51	16.0	0.63	M12 / 1/2"
<b>G74446-24.1</b>	1 1/2"	-24	210	69.8	2.75	17.8	0.70	15.0	0.59	16.0	0.63	M14
<b>G74446-32</b>	2"	-32	210	77.8	3.06	21.4	0.84	13.0	0.51	16.0	0.63	M12 / 1/2"
<b>G74446-40</b>	2 1/2"	-40	175	88.9	3.50	25.4	1.00	13.0	0.51	19.0	0.75	M12 / 1/2"
<b>G74446-48</b>	3"	-48	140	106.4	4.19	31.0	1.22	17.0	0.67	22.0	0.87	M16 / 5/8"
<b>G74446-48.1</b>	3"	-48	140	106.4	4.19	31.0	1.22	15.0	0.59	22.0	0.87	M14
<b>G74446-56</b>	3 1/2"	-56	35	120.7	4.75	34.9	1.37	17.0	0.67	22.4	0.88	M16 / 5/8"

Hole flanges are an integral part of the end fitting and must be ordered at the same time as the fitting and hose assembly.

## O-Rings

Part number	D Ø (mm)	S Ø (mm)
05.018-210	18.6	3.5
05.018-214	25.0	3.5
05.018-219	32.9	3.5
05.018-222	37.7	3.5
05.018-222	37.7	3.5
05.018-222	37.7	3.5
05.018-225	47.2	3.5
05.018-225	47.2	3.5
05.018-228	56.7	3.5
22550-232	69.4	3.5
22550-237	85.3	3.5
22550-237	85.3	3.5
22550-241	98.0	3.5

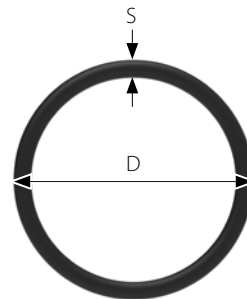

O-Rings have to be ordered separately.

# G74453

4-Hole Flange SAE J518 C Code 61

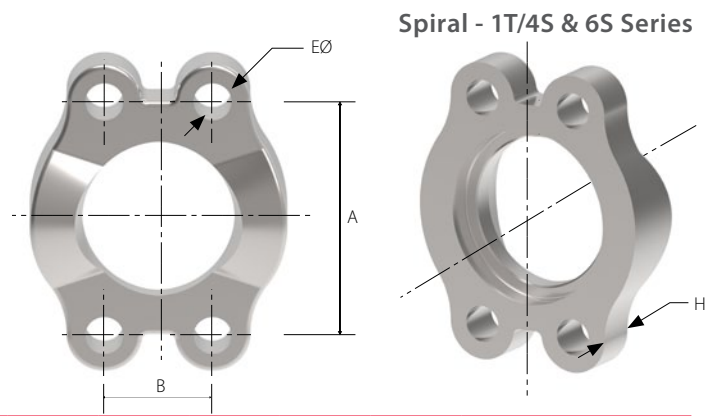

THREAD		HOSE SIZE INFO		DIMENSIONS								
Thread T	Flange size	Size	Max. Oper. Press	A		B		EØ		H		Bolt Ø metric/ inch
			bar	mm	in	mm	in	mm	in	mm	in	
<b>G74453-8</b>	1/2"	-08	345	38,1	1,50	17,5	0,69	8,4	0,33	13,0	0,51	M8 / 5/16"
<b>G74453-12</b>	3/4"	-12	345	47,6	1,87	22,2	0,87	10,5	0,41	14,2	0,56	M10 / 3/8"
<b>G74453-16</b>	1"	-16	345	52,4	2,06	26,2	1,03	10,5	0,41	15,8	0,62	M10 / 3/8"
<b>G74453-20</b>	1 1/4"	-20	275	58,7	2,31	30,2	1,19	12,0	0,47	14,2	0,56	7/16"
<b>G74453-20.1</b>	1 1/4"	-20	275	58,7	2,31	30,2	1,19	10,5	0,41	14,2	0,56	M10
<b>G74453-24</b>	1 1/2"	-24	210	69,8	2,75	35,7	1,41	13,0	0,51	16,0	0,63	M12 / 1/2"
<b>G74453-32</b>	2"	-32	210	77,8	3,06	42,9	1,69	13,0	0,51	16,0	0,63	M12 / 1/2"
<b>G74453-40</b>	2 1/2"	-40	175	88,9	3,50	50,8	2,00	13,0	0,51	19,0	0,75	M12 / 1/2"

4-hole flanges are an integral part of the end fitting and must be ordered at the same time as the fitting and hose assembly.

## O-Rings

Part number	D Ø (mm)	S Ø (mm)
05.018-210	18.6	3.5
05.018-214	25.0	3.5
05.018-219	32.9	3.5
05.018-222	37.7	3.5
05.018-222	37.7	3.5
05.018-225	47.2	3.5
05.018-228	56.7	3.5
05.018-232	69.4	3.5

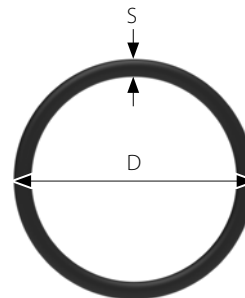

O-Rings have to be ordered separately.

## Hose to fitting chart

Socket type by hose

1T/4S & 6S fittings					
Hose part #	Socket:	Hose part #	Socket:	Hose part #	Socket:
GH425	1T & 4S	EC600	4S & 6S	EC426	1T & 4S
GH425B	1T & 4S	EC525	4S	EC512	4S
GH493	1T & 4S	EC810	4S & 6S	EC420	4S & 6S
FC500	4S & 6S	FC619	4S	EC615	4S & 6S
GH466	6S	GH435	1T & 4S	EC330	1T & 4S

Aeroquip by Danfoss

# Spiral fittings

1W series





## Spiral - 1W series

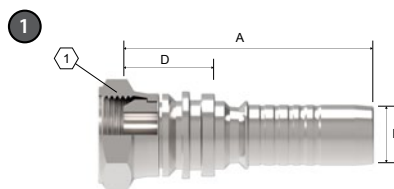

# BF

BSP 60° Cone Female Swivel (BF)

PART	HOSE SIZE INFO			DIMENSIONS									
	Terminal End	Hose size	Thd.	A		D		EØ		H		1	
1W part #				mm	in	mm	in	mm	in	mm	in	mm	mm
<b>1W12BF12</b>	-12	-12	G 3/4"	87.8	3.46	35.8	1.41	15.1	0.59	-	-	32	1.26
<b>1W16BF16</b>	-16	-16	G 1"	105.7	4.16	38.6	1.52	19.6	0.77	-	-	41	1.61
<b>1W20BF20</b>	-20	-20	G 1 1/4"	117.5	4.63	42.6	1.68	25.5	1.00	-	-	50	1.97
<b>1W24BF24</b>	-24	-24	G 1 1/2"	132.0	5.20	33.5	1.32	30.0	1.18	-	-	55	2.17
<b>1W32BF32</b>	-32	-32	G 2"	141.9	5.59	33.5	1.32	42.1	1.66	-	-	70	2.76

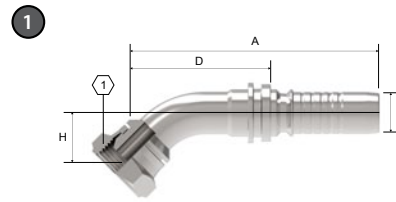

# BFA

BSP 60° Cone Female Swivel - 45° Elbow (BFA)

PART 1W part #	HOSE SIZE INFO			DIMENSIONS									
	Terminal End	Hose size	Thd.	A		D		EØ		H		1	
				mm	in	mm	in	mm	in	mm	in	mm	mm
<b>1W12BFA12</b>	-12	-12	G 3/4"	125.7	4.95	73.7	2.90	15.1	0.59	26.0	1.02	32	1.26
<b>1W16BFA16</b>	-16	-16	G 1"	154.4	6.08	87.8	3.46	19.6	0.77	30.0	1.18	41	1.61
<b>1W20BFA20</b>	-20	-20	G 1 1/4"	179.5	7.07	104.6	4.12	25.5	1.00	34.0	1.34	50	1.97
<b>1W24BFA24</b>	-24	-24	G 1 1/2"	245.2	9.65	146.7	5.78	30.0	1.18	52.3	2.06	55	2.17
<b>1W32BFA32.062</b>	32	-32	G 2"	251.5	9.90	143.1	5.63	42.1	1.66	62.5	2.46	70	2.76

## Spiral - 1W series

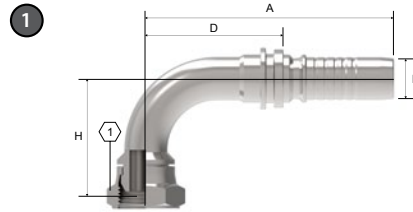

# BFB

BSP 60° Cone Female Swivel - 90° Elbow (BFB)

PART	HOSE SIZE INFO			DIMENSIONS									
	Terminal End	Hose size	Thd.	A		D		EØ		H		1	
1W part #				mm	in	mm	in	mm	in	mm	in	mm	mm
<b>1W12BFB12</b>	-12	-12	G 3/4"	119.3	4.70	67.3	2.65	15.1	0.59	57.0	2.24	32	1.26
<b>1W16BFB16</b>	-16	-16	G 1"	149.6	5.89	83.0	3.27	19.6	0.77	68.0	2.68	41	1.61
<b>1W20BFB20</b>	-20	-20	G 1 1/4"	176.3	6.94	101.4	3.99	25.5	1.00	79.0	3.11	50	1.97
<b>1W24BFB24</b>	-24	-24	G 1 1/2"	233.9	9.21	135.4	5.33	30.0	1.18	115.0	4.53	55	2.17
<b>1W32BFB32.147</b>	-32	-32	G 2"	247.6	9.75	139.2	5.48	42.1	1.66	147.0	5.79	70	2.76

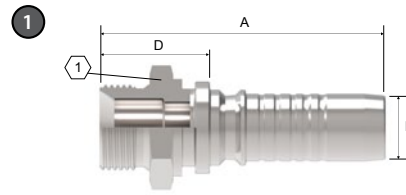

# BP

BSP 60° Cone Male Parallel (BP)

PART 1W part #	HOSE SIZE INFO			DIMENSIONS									
	Terminal End	Hose size	Thread	A		D		EØ		H		1	
		DN		mm	in	mm	in	mm	in	mm	in	mm	mm
<b>1W12BP12</b>	-12	-12	G 3/4" - 14 CL-A	89.8	3.54	37.8	1.49	15.1	0.59	NA	NA	32	1.26
<b>1W16BP16</b>	-16	-16	G 1" - 11 CL-A	108.6	4.28	42.0	1.65	19.6	0.77	NA	NA	41	1.61
<b>1W20BP20</b>	-20	-20	G 1 1/4" - 11	120.0	4.72	45.1	1.78	25.5	1.00	NA	NA	50	1.97
<b>1W24BP24</b>	-24	-24	G 1 1/2" - 11	145.0	5.71	46.5	1.83	30.0	1.18	NA	NA	55	2.17

## Spiral - 1W series

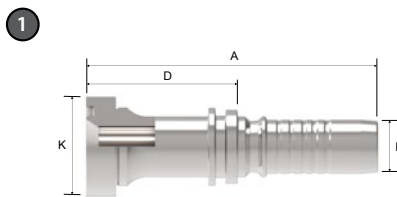

# CT

CAT® Flange (CT)

PART	HOSE SIZE INFO		DIMENSIONS									
	Flange size	Hose size	A		D		EØ		H		KØ	
1W part #			mm	in	mm	in	mm	in	mm	in	mm	in
<b>1W12CT12</b>	3/4"	-12	116.1	4.57	64.1	2.52	15.1	0.59	-	-	41.3	1.63
<b>1W16CT12</b>	1"	-12	122.9	4.84	70.9	2.79	15.1	0.59	-	-	47.6	1.87
<b>1W16CT16</b>	1"	-16	138.7	5.46	72.1	2.84	19.6	0.77	-	-	47.6	1.87
<b>1W20CT16</b>	1 1/4"	-16	138.7	5.46	72.1	2.84	19.6	0.77	-	-	54.0	2.13
<b>1W20CT20</b>	1 1/4"	-20	153.0	6.02	78.1	3.07	25.5	1.00	-	-	54.0	2.13
<b>1W24CT20</b>	1 1/2"	-20	187.7	7.39	112.8	4.44	25.5	1.00	-	-	63.5	2.50
<b>1W24CT24</b>	1 1/2"	-24	204.6	8.06	106.1	4.18	30.0	1.18	-	-	63.5	2.50

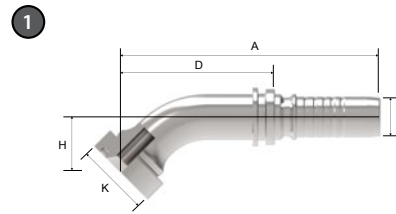

# CTA

CAT® Flange - 45° Elbow (CTA)

PART 1W part #	HOSE SIZE INFO		DIMENSIONS									
	Flange size	Hose size	A		D		EØ		H		KØ	
			mm	in	mm	in	mm	in	mm	in	mm	in
<b>1W12CTA12</b>	3/4"	-12	134.0	5.28	82.0	3.23	15.1	0.59	30.8	1.21	41.3	1.63
<b>1W16CTA12</b>	1"	-12	148.2	5.83	96.2	3.79	15.1	0.59	35.3	1.39	47.6	1.87
<b>1W16CTA16</b>	1"	-16	164.0	6.46	97.3	3.83	19.6	0.77	35.3	1.39	47.6	1.87
<b>1W20CTA16</b>	1 1/4"	-16	182.5	7.19	115.8	4.56	19.6	0.77	41.8	1.65	54.0	2.13
<b>1W20CTA20</b>	1 1/4"	-20	192.8	7.59	117.9	4.64	25.5	1.00	41.8	1.65	54.0	2.13
<b>1W24CTA20</b>	1 1/2"	-20	207.4	8.17	132.5	5.22	25.5	1.00	46.2	1.82	63.5	2.50
<b>1W24CTA24</b>	1 1/2"	-24	221.4	8.72	122.9	4.84	30.0	1.18	46.2	1.82	63.5	2.50

## Spiral - 1W series

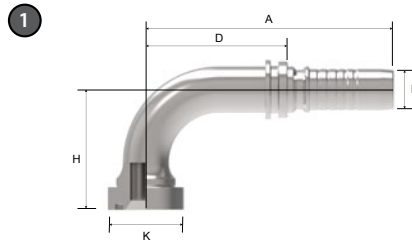

# CTB

CAT® Flange - 90° Elbow (CTB)

PART	HOSE SIZE INFO		DIMENSIONS									
	Flange size	Hose size	A		D		EØ		H		KØ	
1 1W part #			mm	in	mm	in	mm	in	mm	in	mm	in
<b>1W12CTB12</b>	3/4"	-12	124.8	4.91	72.8	2.87	15.1	0.59	64.0	2.52	41.3	1.63
<b>1W16CTB12</b>	1"	-12	139.8	5.50	87.8	3.46	15.1	0.59	75.7	2.98	47.6	1.87
<b>1W16CTB16</b>	1"	-16	155.6	6.13	89.0	3.50	19.6	0.77	75.7	2.98	47.6	1.87
<b>1W20CTB16</b>	1 1/4"	-16	174.6	6.87	108.0	4.25	19.6	0.77	92.9	3.66	54.0	2.13
<b>1W20CTB20</b>	1 1/4"	-20	185.0	7.28	110.1	4.33	25.5	1.00	92.9	3.66	54.0	2.13
<b>1W24CTB20</b>	1 1/2"	-20	201.1	7.92	126.1	4.96	25.5	1.00	105.7	4.16	63.5	2.50
<b>1W24CTB24</b>	1 1/2"	-24	215.1	8.47	116.6	4.59	30.0	1.18	105.7	4.16	63.5	2.50

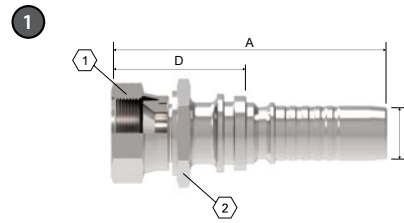

# FJ

JIC 37° Female Swivel (FJ)

PART	HOSE SIZE INFO			DIMENSIONS									
	Terminal End	Hose size	Thd.	A		D		EØ		1		2	
1W part #				mm	in	mm	in	mm	in	mm	in	mm	in
<b>1WW12FJ12</b>	-12	-12	1 1/16" - 12	94.6	3.72	42.6	1.68	15.1	0.59	32	1.26	35	1.37
<b>1WW16FJ16</b>	-16	-16	1 5/16" - 12	115.4	4.54	48.8	1.92	19.6	0.77	41	1.61	44	1.75
<b>1WW20FJ20</b>	-20	-20	1 5/8" - 12	130.1	5.12	55.2	2.17	25.5	1.00	50	1.97	51	2.00
<b>1W24FJ24</b>	-24	-24	1 7/8"	172.3	6.78	73.8	2.91	30.0	1.18	60	2.36	-	-
<b>1W32FJ32</b>	-32	-32	2 1/2"	146.9	5.78	38.5	1.52	42.1	1.66	75	2.95	-	-



## Spiral - 1W series

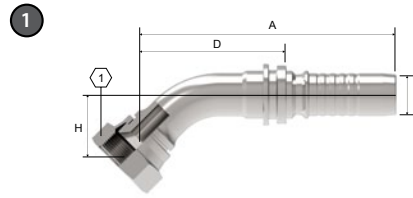

# FJA

JIC 37° Female Swivel - 45° Elbow (FJA)

PART	HOSE SIZE INFO			DIMENSIONS									
	Terminal End	Hose size	Thd.	A		D		EØ		H		1	
1W part #				mm	in	mm	in	mm	in	mm	in	mm	in
<b>1W12FJA12</b>	-12	-12	1 1/16" - 12	126.7	4.99	74.7	2.94	15.1	0.59	27.0	1.06	32	1.26
<b>1W16FJA16</b>	-16	-16	1 5/16" - 12	157.4	6.20	90.8	3.57	19.6	0.77	33.0	1.30	41	1.61
<b>1W20FJA20</b>	-20	-20	1 5/8" - 12	182.7	7.19	107.7	4.24	25.5	1.00	37.1	1.46	50	1.97
<b>1W24FJA24</b>	-24	-24	1 7/8" - 12	245.2	9.65	146.7	5.78	30.0	1.18	52.3	2.06	60	2.36

# FJB

JIC 37° Female Swivel - 90° Elbow (FJB)

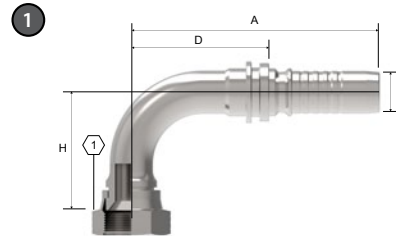

PART 1W part #	HOSE SIZE INFO			DIMENSIONS									
	Terminal End	Hose size	Thd.	A		D		EØ		H		1	
				mm	in	mm	in	mm	in	mm	in	mm	in
<b>1W12FJB12</b>	-12	-12	1 1/16" - 12	119.3	4.70	67.3	2.65	15.1	0.59	58.0	2.28	32	1.26
<b>1W16FJB16</b>	-16	-16	1 5/16" - 12	149.6	5.89	83.0	3.27	19.6	0.77	71.0	2.80	41	1.61
<b>1W20FJB20</b>	-20	-20	1 5/8" - 12	176.3	6.94	101.4	3.99	25.5	1.00	82.0	3.23	50	1.97
<b>1W24FJB24</b>	-24	-24	1 7/8" - 12	233.9	9.21	135.4	5.33	30.0	1.18	115.0	4.53	60	2.36
<b>1W32FJB32.141</b>	-32	-32	2 1/2" - 12	247.6	9.75	139.2	5.48	42.1	1.66	141.0	5.55	75	2.95

## Spiral - 1W series

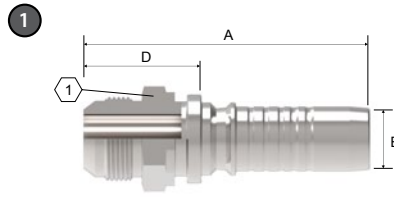

# MJ

JIC 37° Male (MJ)

PART	HOSE SIZE INFO			DIMENSIONS									
	Terminal End	Hose size	Thd.	A		D		EØ		H		1	
1W part #				mm	in	mm	in	mm	in	mm	in	mm	in
<b>1W12MJ12</b>	-12	-12	1 1/16" - 12	94.7	3.73	42.6	1.68	15.1	0.59	-	-	30	1.18
<b>1W16MJ16</b>	-16	-16	1 5/16" - 12	113.4	4.46	46.7	1.84	19.6	0.77	-	-	36	1.42
<b>1W20MJ20</b>	-20	-20	1 5/8" - 12	127.0	5.00	52.1	2.05	25.5	1.00	-	-	46	1.81
<b>1W24MJ24</b>	-24	-24	1 7/8" - 12	148.0	5.83	49.5	1.95	30.0	1.18	-	-	50	1.97

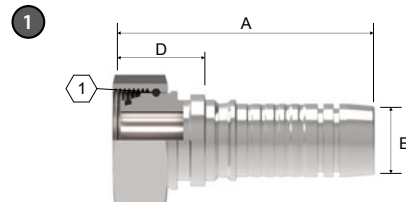

# DL

DIN 24° DKO Light Female Swivel (DL)

PART	HOSE SIZE INFO			DIMENSIONS										
	1W part #	Tube O.D.	Hose size	Thd.	A		D		EØ		H		1	
					mm	in	mm	in	mm	in	mm	in	mm	in
<b>1W32DL20</b>		35	-20	M45 x 2.0	112.3	4.42	37.4	1.47	25.5	1.00	-	-	50	1.97
<b>1W40DL24</b>		42	-24	M52 x 2.0	135.3	5.33	36.8	1.45	30.0	1.18	-	-	60	2.36

## Spiral - 1W series

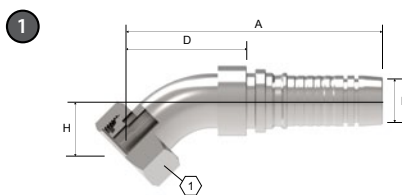

# DLA

DIN 24° DKO Light Female Swivel - 45° Elbow (DLA)

PART	HOSE SIZE INFO			DIMENSIONS									
	1W part #	Tube O.D.	Hose size	A		D		EØ		H		1	
			Thd.	mm	in	mm	in	mm	in	mm	in	mm	in
<b>1W32DLA20</b>	35	-20	M45 x 2.0	162.8	6.41	87.9	3.46	25.5	1.00	33.6	1.32	50	1.97
<b>1W40DLA24</b>	42	-24	M52 x 2.0	197.0	7.76	98.6	3.88	30.0	1.18	39.0	1.54	60	2.36

# DLB

DIN 24° DKO Light Female Swivel - 90° Elbow (DLB)

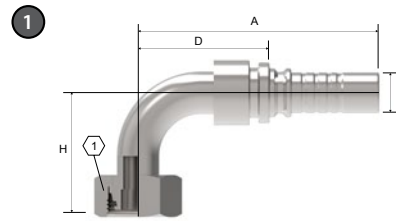

PART 1W part #	HOSE SIZE INFO			DIMENSIONS									
	Tube O.D.	Hose size	Thd.	A		D		EØ		H		1	
				mm	in	mm	in	mm	in	mm	in	mm	in
<b>1W32DLB20.077</b>	35	-20	M45 x 2.0	158.5	6.24	83.6	3.29	25.5	1.00	76.8	3.02	50	1.97
<b>1W32DLB20.090</b>	35	-20	M45 x 2.0	172.0	6.77	97.1	3.82	25.5	1.00	90.3	3.56	50	1.97
<b>1W40DLB24</b>	42	-24	M52 x 2.0	203.0	7.99	104.5	4.11	30.0	1.18	100.3	3.95	60	2.36

## Spiral - 1W series

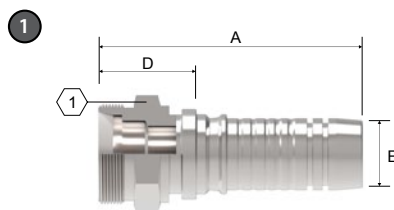

# DK

DIN 24° DKO Light Male (DK)

PART	HOSE SIZE INFO			DIMENSIONS										
	1W part #	Tube O.D.	Hose size	Thd.	A		D		EØ		H		1	
					mm	in	mm	in	mm	in	mm	in	mm	in
<b>1W32DK20</b>	35	-20	M45 x 2.0		119.1	4.69	44.2	1.74	25.5	1.00	-	-	46	1.81

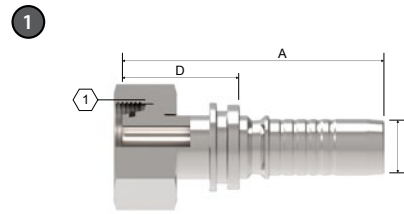

# DS

DIN 24° DKO Heavy Female Swivel (DS)

PART	HOSE SIZE INFO			DIMENSIONS										
	1W part #	Tube O.D.	Hose size	Thd.	A		D		EØ		H		1	
					mm	in	mm	in	mm	in	mm	in	mm	in
<b>1W16DS12</b>		20	-12	M30 x 2.0	103.2	4.06	51.2	2.02	15.1	0.59	-	-	36	1.42
<b>1W20DS12</b>		25	-12	M36 x 2.0	103.2	4.06	51.2	2.02	15.1	0.59	-	-	46	1.81
<b>1W20DS16</b>		25	-16	M36 x 2.0	122.0	4.80	55.4	2.18	19.6	0.77	-	-	41	1.61
<b>1W25DS16</b>		30	-16	M42 x 2.0	120.6	4.75	54.0	2.13	19.6	0.77	-	-	50	1.97
<b>1W32DS16</b>		38	-16	M52 x 2.0	124.6	4.91	57.8	2.28	19.6	0.77	-	-	60	2.36
<b>1W25DS20</b>		30	-20	M42 x 2.0	116.2	4.57	41.3	1.63	25.5	1.00	-	-	50	1.97
<b>1W32DS20</b>		38	-20	M52 x 2.0	134.9	5.31	60.0	2.36	25.5	1.00	-	-	60	2.36
<b>1W32DS24</b>		38	-24	M52 x 2.0	137.0	5.39	38.5	1.52	30.0	1.18	-	-	60	2.36
<b>1W40DS24</b>		50	-24	M68 x 2.0	141.0	5.55	42.5	1.67	30.0	1.18	-	-	80	3.15



## Spiral - 1W series

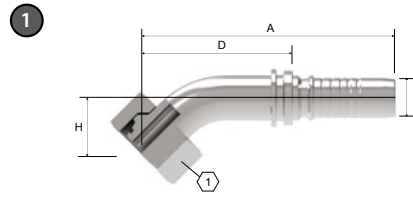

# DSA

DIN 24° DKO Heavy Female Swivel - 45° Elbow (DSA)

PART	HOSE SIZE INFO			DIMENSIONS									
	Tube O.D.	Hose size	Thd.	A		D		EØ		H		①	
① 1W part #				mm	in	mm	in	mm	in	mm	in	mm	in
<b>1W16DSA12.029</b>	20	-12	M30 x 2.0	132.1	5.20	80.1	3.15	15.1	0.59	29.1	1.15	36	1.42
<b>1W16DSA12.040</b>	20	-12	M30 x 2.0	135.8	5.35	83.8	3.30	15.1	0.59	40.0	1.57	36	1.42
<b>1W20DSA12</b>	25	-12	M36 x 2.0	135.1	5.32	83.1	3.27	15.1	0.59	32.0	1.26	46	1.81
<b>1W32DSA12</b>	38	-12	M52 x 2.0	168.4	6.63	116.4	4.58	15.1	0.59	47.0	1.85	60	2.36
<b>1W20DSA16.033</b>	25	-16	M36 x 2.0	145.7	5.74	79.0	3.11	19.6	0.77	32.9	1.30	41	1.61
<b>1W25DSA16</b>	30	-16	M42 x 2.0	163.6	6.44	97.0	3.82	19.6	0.77	35.0	1.38	50	1.97
<b>1W25DSA16.042</b>	30	-16	M42 x 2.0	164.2	6.46	97.6	3.84	20.0	0.79	41.4	1.63	50	1.97
<b>1W25DSA20</b>	30	-20	M42 x 2.0	195.3	7.69	120.4	4.74	25.5	1.00	39.9	1.57	50	1.97
<b>1W32DSA16.063</b>	38	-16	M52 x 2.0	185.6	7.31	119.0	4.69	19.6	0.77	63.0	2.48	60	2.36
<b>1W32DSA20.063</b>	38	-20	M52 x 2.0	225.6	8.88	150.7	5.93	25.5	1.00	63.0	2.48	60	2.36
<b>1W32DSA20</b>	38	-20	M52 x 2.0	190.0	7.48	115.1	4.53	25.5	1.00	39.0	1.54	60	2.36
<b>1W32DSA24</b>	38	-24	M52 x 2.0	198.0	7.80	99.0	3.90	30.0	1.18	39.5	1.56	60	2.36

# DSB

DIN 24° DKO Heavy Female Swivel - 90° Elbow (DSB)

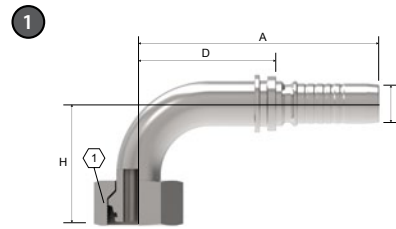

PART 1W part #	HOSE SIZE INFO			DIMENSIONS									
	Tube O.D.	Hose size	Thd.	A		D		EØ		H		1	
				mm	in	mm	in	mm	in	mm	in	mm	in
<b>1W16DSB12</b>	20	-12	M30 x 2.0	110.4	4.35	58.4	2.30	15.1	0.59	54.0	2.13	-	-
<b>1W16DSB12.120</b>	20	-12	M30 x 2.0	110.4	4.35	58.4	2.30	15.1	0.59	120.0	4.72	-	-
<b>1W20DSB12</b>	25	-12	M36 x 2.0	124.8	4.91	72.8	2.87	15.1	0.59	65.0	2.56	46	1.81
<b>1W20DSB12.077</b>	25	-12	M36 x 2.0	124.7	4.91	72.7	2.86	15.1	0.59	76.5	3.01	46	1.81
<b>1W20DSB12.100</b>	25	-12	M36 x 2.0	130.9	5.15	78.9	3.11	15.1	0.59	101.5	4.00	60	2.36
<b>1W20DSB12.150</b>	25	-12	M36 x 2.0	123.4	4.86	81.7	3.22	15.1	0.59	150.0	5.91	60	2.36
<b>1W20DSB16</b>	25	-16	M36 x 2.0	144.2	5.68	77.6	3.06	19.6	0.77	74.0	2.91	41	1.61
<b>1W25DSB16</b>	30	-16	M42 x 2.0	155.6	6.13	89.0	3.50	19.6	0.77	76.0	2.99	50	1.97
<b>1W25DSB16.085</b>	30	-16	M42 x 2.0	148.6	5.85	81.9	3.22	19.6	0.77	84.5	3.33	50	1.97
<b>1W25DSB16.140</b>	30	-16	M42 x 2.0	155.6	6.13	89.0	3.50	19.6	0.77	140.0	5.51	50	1.97
<b>1W25DSB20.083</b>	30	-20	M42 x 2.0	153.5	6.04	78.6	3.09	25.5	1.00	82.5	3.25	50	1.97
<b>1W25DSB20.83V</b>	30	-20	M42 x 2.0	153.5	6.04	78.6	3.09	25.5	1.00	82.5	3.25	50	1.97
<b>1W32DSB20</b>	38	-20	M52 x 2.0	185.0	7.28	110.1	4.33	25.5	1.00	89.0	3.50	60	2.36
<b>1W32DSB24</b>	38	-24	M52 x 2.0	195.0	7.68	96.5	3.80	30.0	1.18	93.5	3.68	60	2.36

## Spiral - 1W series

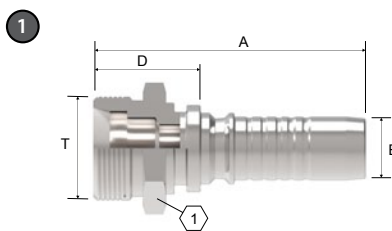

# EK

DIN 24° DKO Heavy Male (EK)

PART	HOSE SIZE INFO			DIMENSIONS										
	1W part #	Tube O.D.	Hose size	Thd.	A		D		EØ		H		1	
					mm	in	mm	in	mm	in	mm	in	mm	in
<b>1W16EK12</b>	20	-12	M30 x 2.0		86.4	3.40	34.4	1.35	15.1	0.59	-	-	32	1.26
<b>1W20EK12</b>	25	-12	M36 x 2.0		88.4	3.48	36.4	1.43	15.1	0.59	-	-	41	1.61
<b>1W25EK16</b>	30	-16	M42 x 2.0		110.0	4.33	43.4	1.71	19.6	0.77	-	-	46	1.81
<b>1W32EK20</b>	38	-20	M52 x 2.0		124.4	4.90	49.5	1.95	25.5	1.00	-	-	55	2.17

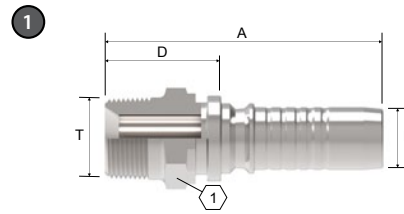

# MP

Male Pipe (MP)

PART	HOSE SIZE INFO			DIMENSIONS							
	Terminal End	Hose size	Thread	A		D		EØ		1	
1W part #				mm	in	mm	in	mm	in	mm	in
<b>1W12MP12</b>	-12	-12	3/4" - 14	92.1	3.63	40.1	1.58	15.1	0.59	30	1.18
<b>1W16MP16</b>	-16	-16	1 - 11 1/2"	114.5	4.51	47.9	1.88	19.6	0.77	36	1.42

## Spiral - 1W series

1

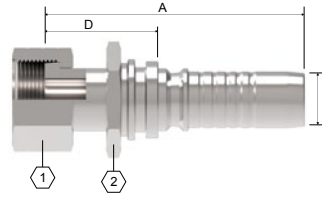

# FR

ORS Female Swivel (FR)

PART 1W part #	HOSE SIZE INFO			DIMENSIONS									
	Terminal End	Hose size	Thd.	A		D		EØ		1		2	
				mm	in	mm	in	mm	in	mm	in	mm	in
<b>1WW12FR12</b>	-12	-12	1 3/16" - 12	100.7	3.96	48.7	1.92	15.1	0.59	36	1.42	35	1.37
<b>1WW16FR16</b>	-16	-16	1 7/16" - 12	118.3	4.66	51.7	2.04	19.6	0.77	41	1.61	44	1.75
<b>1WW20FR20</b>	-20	-20	1 11/16" - 12	133.4	5.25	58.4	2.30	25.5	1.00	50	1.97	51	2.00

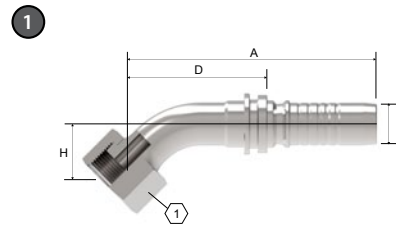

# FRA

ORS Female Swivel - 45° Elbow (FRA)

PART 1W part #	HOSE SIZE INFO			DIMENSIONS									
	Terminal End	Hose size	Thd.	A		D		EØ		H		1	
				mm	in	mm	in	mm	in	mm	in	mm	in
<b>1W12FRA12</b>	-12	-12	1 3/16" - 12	123.7	4.87	71.7	2.82	15.1	0.59	24.0	0.94	36	1.42
<b>1W16FRA16</b>	-16	-16	1 7/16" - 12	152.4	6.00	85.8	3.38	19.6	0.77	28.0	1.10	41	1.61
<b>1W20FRA20</b>	-20	-20	1 11/16" - 12	176.6	6.95	101.7	4.00	25.5	1.00	31.0	1.22	50	1.97

## Spiral - 1W series

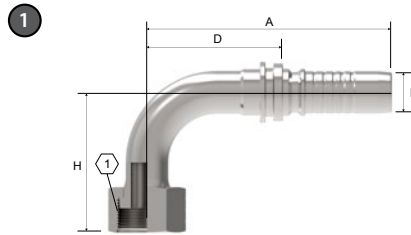

# FRB

ORS Female Swivel - 90° Elbow (FRB)

PART	HOSE SIZE INFO			DIMENSIONS									
	Terminal End	Hose size	Thd.	A		D		EØ		H		1	
1W part #				mm	in	mm	in	mm	in	mm	in	mm	in
<b>1W12FRB12</b>	-12	-12	1 3/16" - 12	119.3	4.70	67.3	2.65	15.1	0.59	58.0	2.28	36	1.42
<b>1W16FRB16</b>	-16	-16	1 7/16" - 12	149.6	5.89	83.0	3.27	19.6	0.77	71.0	2.80	41	1.61
<b>1W20FRB20</b>	-20	-20	1 11/16" - 12	176.3	6.94	101.4	3.99	25.5	1.00	78.0	3.07	50	1.97

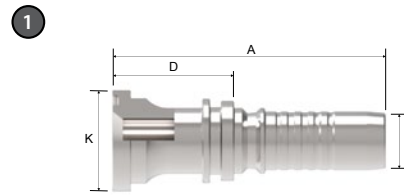

# FL

SAE CODE 61 Flange (FL)

PART	HOSE SIZE INFO		DIMENSIONS										
	1W part #	Flange size	Hose size	A		D		EØ		H		KØ	
				mm	in	mm	in	mm	in	mm	in	mm	in
<b>1W12FL12</b>		3/4"	-12	104.3	4.11	52.3	2.06	15.1	0.59	-	-	38.1	1.50
<b>1W16FL12</b>		1"	-12	104.3	4.11	52.3	2.06	15.1	0.59	-	-	44.4	1.75
<b>1W16FL16</b>		1"	-16	120.1	4.73	53.4	2.10	19.6	0.77	-	-	44.4	1.75
<b>1W20FL16</b>		1 1/4"	-16	127.7	5.03	61.1	2.41	19.6	0.77	-	-	50.8	2.00
<b>1W20FL20</b>		1 1/4"	-20	138.1	5.44	63.2	2.49	25.5	1.00	-	-	50.8	2.00
<b>1W24FL20</b>		1 1/2"	-20	146.0	5.75	71.1	2.80	25.5	1.00	-	-	60.3	2.37
<b>1W24FL24</b>		1 1/2"	-24	181.2	7.13	82.7	3.26	30.0	1.18	-	-	60.3	2.37
<b>1W32FL24</b>		2"	-24	184.3	7.26	85.8	3.38	30.0	1.18	-	-	71.4	2.81
<b>1W32FL32</b>		2"	-32	171.9	6.77	63.4	2.50	42.1	1.66	-	-	71.4	2.81
<b>1W40FL32</b>		2 1/2"	-32	199.6	7.86	91.2	3.59	42.1	1.66	-	-	84.1	3.31



## Spiral - 1W series

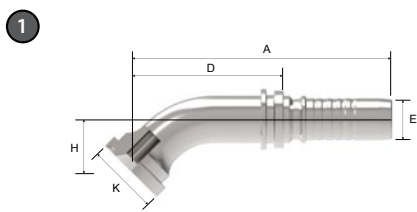

# FLA

SAE CODE 61 Flange - 45° Elbow (FLA)

PART	HOSE SIZE INFO		DIMENSIONS									
	Flange size	Hose size	A		D		EØ		H		KØ	
1W part #			mm	in	mm	in	mm	in	mm	in	mm	in
<b>1W12FLA12</b>	3/4"	-12	130.1	5.12	78.1	3.07	15.1	0.59	27.0	1.06	38.1	1.50
<b>1W16FLA16</b>	1"	-16	160.6	6.32	92.8	3.65	19.6	0.77	32.0	1.26	44.4	1.75
<b>1W20FLA16</b>	1 1/4"	-16	179.7	7.07	113.0	4.45	19.6	0.77	39.0	1.54	50.8	2.00
<b>1W20FLA20</b>	1 1/4"	-20	190.0	7.48	115.1	4.53	25.5	1.00	39.0	1.54	50.8	2.00
<b>1W20FLA20.045</b>	1 1/4"	-20	181.3	7.14	106.4	4.19	25.5	1.00	45.0	1.77	50.7	2.00
<b>1W24FLA24</b>	1 1/2"	-24	238.1	9.37	139.6	5.50	30.0	1.18	45.0	1.77	60.2	2.37
<b>1W24FLA24.035</b>	1 1/2"	-24	192.6	7.58	94.1	3.70	30.0	1.18	34.6	1.36	60.2	2.37
<b>1W24FLA24.085</b>	1 1/2"	-24	277.7	10.93	179.2	7.06	30.0	1.18	84.6	3.33	60.2	2.37
<b>1W32FLA24</b>	2"	-24	250.4	9.86	151.9	5.98	30.0	1.18	57.3	2.26	71.4	2.81
<b>1W32FLA32.054</b>	2"	-32	242.35	9.54	133.9	5.27	42.1	1.66	53.3	2.10	71.4	2.81

# FLB

SAE CODE 61 Flange - 90° Elbow (FLB)

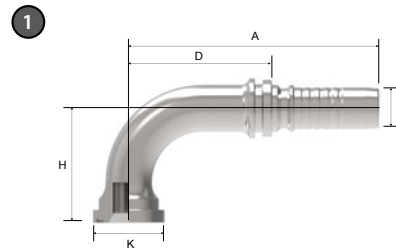

PART	HOSE SIZE INFO		DIMENSIONS										
	1W part #	Flange size	Hose size	A		D		EØ		H		KØ	
				mm	in	mm	in	mm	in	mm	in	mm	in
<b>1</b>													
<b>1W12FLB12</b>		3/4"	-12	124.8	4.91	72.8	2.87	15.1	0.59	59.0	2.32	38.1	1.50
<b>1W16FLB12</b>		1"	-12	139.8	5.50	87.8	3.46	15.1	0.59	71.0	2.80	44.5	1.75
<b>1W16FLB16</b>		1"	-16	155.6	6.13	88.9	3.50	19.6	0.77	71.0	2.80	44.4	1.75
<b>1W20FLB16</b>		1 1/4"	-16	174.7	6.88	108.0	4.25	19.6	0.77	89.0	3.50	50.8	2.00
<b>1W20FLB16.097</b>		1 1/4"	-16	177.4	6.98	110.8	4.36	19.6	0.77	96.5	3.80	50.8	2.00
<b>1W16FLB20</b>		1"	-20	158.5	6.24	83.6	3.29	25.5	1.00	64.5	2.54	44.3	1.74
<b>1W20FLB20</b>		1 1/4"	-20	185.0	7.28	110.1	4.33	25.5	1.00	89.0	3.50	50.8	2.00
<b>1W20FLB20.075</b>		1 1/4"	-20	163.5	6.44	88.6	3.49	25.5	1.00	75.0	2.95	50.7	2.00
<b>1W20FLB20.150</b>		1 1/4"	-20	168.5	6.63	93.6	3.69	25.5	1.00	149.5	5.89	50.7	2.00
<b>1W24FLB20.086</b>		1 1/2"	-20	173.5	6.83	98.6	3.88	25.5	1.00	86.0	3.39	60.2	2.37
<b>1W24FLB24</b>		1 1/2"	-24	234.0	9.21	135.5	5.33	30.0	1.18	104.0	4.09	60.2	2.37
<b>1W24FLB24.150</b>		1 1/2"	-24	190.0	7.48	91.5	3.60	30.0	1.18	150.5	5.93	60.2	2.37
<b>1W32FLB24</b>		2"	-24	234.0	9.21	135.5	5.33	30.0	1.18	137.9	5.43	71.4	2.81
<b>1W32FLB32.134</b>		2"	-32	247.6	9.75	139.2	5.48	42.1	1.66	134.0	5.28	71.4	2.81

## Spiral - 1W series

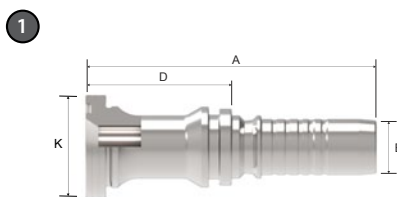

# FH

SAE CODE 62 Flange (FH)

PART	HOSE SIZE INFO		DIMENSIONS									
	Flange size	Hose size	A		D		EØ		H		KØ	
1 1W part #			mm	in	mm	in	mm	in	mm	in	mm	in
<b>1W12FH12</b>	3/4"	-12	110.6	4.35	58,6	2,31	15.1	0.59	-	-	41,3	1,63
<b>1W16FH12</b>	1"	-12	118.2	4.65	66,2	2,61	15.1	0.59	-	-	47,7	1,88
<b>1W12FH16</b>	3/4"	-16	141.4	5.57	74,8	2,94	19.6	0.77	-	-	41,3	1,63
<b>1W16FH16</b>	1"	-16	134.0	5.28	67,4	2,65	19.6	0.77	-	-	47,7	1,88
<b>1W20FH16</b>	1 1/4"	-16	134.9	5.31	68,3	2,69	19.6	0.77	-	-	54,0	2,13
<b>1W16FH20</b>	1"	-20	166.4	6.55	91,5	3,60	25.5	1.00	-	-	47,7	1,88
<b>1W20FH20</b>	1 1/4"	-20	145.2	5.72	70,3	2,77	25.5	1.00	-	-	54,0	2,13
<b>1W24FH20</b>	1 1/2"	-20	162.0	6.38	87,1	3,43	25.5	1.00	-	-	63,5	2,50
<b>1W20FH24</b>	1 1/4"	-24	203.0	7.99	104,5	4,11	30.0	1.18	-	-	54,0	2,13
<b>1W24FH24</b>	1 1/2"	-24	203.0	7.99	104,5	4,11	30.0	1.18	-	-	63,5	2,50
<b>1W32FH24</b>	2"	-24	203.0	7.99	104,5	4,11	30.0	1.18	-	-	79,4	3,13
<b>1W24FH32</b>	1 1/2"	-32	212.6	8.37	104,2	4,10	42.1	1.66	-	-	63,5	2,50
<b>1W32FH32</b>	2"	-32	200.8	7.91	92,4	3,64	42.1	1.66	-	-	79,4	3,13

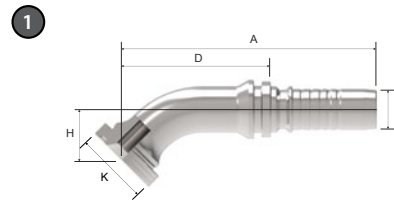

# FHA

SAE CODE 62 Flange - 45° Elbow (FHA)

PART	HOSE SIZE INFO		DIMENSIONS									
	Flange size	Hose size	A		D		EØ		H		KØ	
1 1W part #			mm	in	mm	in	mm	in	mm	in	mm	in
1W12FHA12	3/4"	-12	130.1	5.12	78.1	3.07	15.1	0.59	27.0	1.06	41.3	1.63
1W12FHA12.035	3/4"	-12	138.2	5.44	86.2	3.39	15.1	0.59	35.0	1.38	41.3	1.63
1W12FHA12.040	3/4"	-12	152.9	6.02	100.9	3.97	15.1	0.59	40.0	1.57	41.3	1.63
1W12FHA12.053	3/4"	-12	155.8	6.13	103.8	4.09	15.1	0.59	52.7	2.07	41.3	1.63
1W12FHA12.083	3/4"	-12	186.1	7.33	134.1	5.28	15.1	0.59	83.0	3.27	41.3	1.63
1W16FHA12	1"	-12	144.9	5.70	92.9	3.66	15.1	0.59	32.0	1.26	47.6	1.87
1W16FHA12.044	1"	-12	138.8	5.46	86.8	3.42	15.1	0.59	43.9	1.73	47.6	1.87
1W16FHA12.054	1"	-22	154.3	6.07	102.3	4.03	15.1	0.59	54.4	2.14	47.6	1.87
1W12FHA16.026	3/4"	-16	138.7	5.46	72.0	2.83	19.6	0.77	26.0	1.02	41.3	1.63
1W12FHA16.047	3/4"	-16	162.4	6.39	95.7	3.77	19.6	0.77	46.6	1.83	41.3	1.63
1W12FHA16.053	3/4"	-16	183.7	7.23	117.1	4.61	19.6	0.77	52.7	2.07	41.3	1.63
1W16FHA16	1"	-16	160.6	6.32	94.0	3.70	19.6	0.77	32.0	1.26	47.6	1.87
1W16FHA16.041	1"	-16	169.7	6.68	103.0	4.06	19.6	0.77	41.0	1.61	47.6	1.87
1W16FHA16.050	1"	-16	178.6	7.03	112.0	4.41	19.6	0.77	50.0	1.97	47.7	1.88
1W20FHA16	1 1/4"	-16	179.6	7.07	113.0	4.45	19.6	0.77	39.0	1.54	54.0	2.13
1W20FHA16.050	1 1/4"	-16	190.6	7.50	124.0	4.88	19.6	0.77	50.0	1.97	54.0	2.13
1W20FHA16.074	1 1/4"	-16	191.3	7.53	124.7	4.91	19.6	0.77	73.6	2.90	54.0	2.13
1W16FHA20.041	1"	-20	167.9	6.61	93.0	3.66	25.5	1.00	40.8	1.61	47.6	1.87
1W20FHA20	1 1/4"	-20	190.0	7.48	115.1	4.53	25.5	1.00	39.1	1.54	54.0	2.13
1W20FHA20.045	1 1/4"	-20	196.0	7.72	121.1	4.77	25.5	1.00	45.0	1.77	54.0	2.13
1W20FHA20.060	1 1/4"	-20	211.1	8.31	136.1	5.36	25.5	1.00	60.0	2.36	54.0	2.13
1W24FHA20.037	1 1/2"	-20	173.6	6.83	98.7	3.89	25.5	1.00	37.3	1.47	63.5	2.50
1W24FHA20.064	1 1/2"	-20	205.8	8.10	130.9	5.15	25.5	1.00	63.5	2.50	63.5	2.50
1W24FHA24.042	1 1/2"	-24	206.0	8.11	108.0	4.25	30.0	1.18	42.0	1.65	63.5	2.50
1W24FHA24.070	1 1/2"	-24	263.0	10.35	164.5	6.48	30.0	1.18	70.0	2.76	63.5	2.50
1W24FHA24.080	1 1/2"	-24	273.0	10.75	174.5	6.87	30.0	1.18	80.0	3.15	63.5	2.50
1W32FHA24.070	2"	-24	263.0	10.35	164.5	6.48	30.0	1.18	70.0	2.76	79.4	3.13
1W32FHA32.069	2"	-32	297.6	11.72	189.2	7.45	42.1	1.66	69.0	2.72	79.4	3.13

## Spiral - 1W series

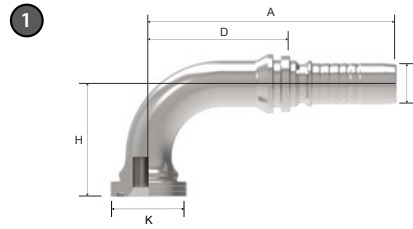

# FHB

SAE CODE 62 Flange - 90° Elbow (FHB)

PART		HOSE SIZE INFO		DIMENSIONS								
① 1W part #	Flange size	Hose size	A		D		EØ		H		KØ	
			mm	in	mm	in	mm	in	mm	in	mm	in
1W12FHB12	3/4"	-12	124.8	4.91	72.8	2.87	15.1	0.59	59.0	2.32	41.3	1.63
1W12FHB12.058	3/4"	-12	118.4	4.66	66.4	2.61	15.1	0.59	58.0	2.28	41.3	1.63
1W12FHB12.068	3/4"	-12	124.0	4.88	72.0	2.83	15.1	0.59	68.0	2.68	41.3	1.63
1W12FHB12.086	3/4"	-12	124.8	4.91	72.8	2.87	15.1	0.59	86.0	3.39	41.3	1.63
1W12FHB12.108	3/4"	-12	128.4	5.06	76.4	3.01	15.1	0.59	108.0	4.25	41.3	1.63
1W12FHB12.150	3/4"	-12	124.8	4.91	72.8	2.87	15.1	0.59	150.0	5.91	41.3	1.63
1W16FHB12	1"	-12	139.8	5.50	87.8	3.46	15.1	0.59	71.0	2.80	47.6	1.87
1W16FHB12.086	1"	-12	135.0	5.31	83.0	3.27	15.1	0.59	86.0	3.39	47.7	1.88
1W16FHB12.102	1"	-12	128.4	5.06	76.4	3.01	15.1	0.59	102.5	4.04	47.6	1.87
1W16FHB12.140	1"	-12	139.8	5.50	87.8	3.46	15.1	0.59	140.0	5.51	47.6	1.87
1W20FHB12	1 1/4"	-12	132.9	5.23	80.9	3.19	15.1	0.59	80.0	3.15	54.0	2.13
1W12FHB16.068	3/4"	-16	144.2	5.68	77.6	3.06	19.6	0.77	68.0	2.68	41.3	1.63
1W12FHB16.078	3/4"	-16	142.0	5.59	75.4	2.97	19.6	0.77	78.0	3.07	41.3	1.63
1W12FHB16.086	3/4"	-16	145.8	5.74	79.2	3.12	19.6	0.77	86.0	3.39	41.3	1.63
1W12FHB16.110	3/4"	-16	144.2	5.68	77.6	3.06	19.6	0.77	110.0	4.33	41.3	1.63
1W12FHB16.130	3/4"	-16	144.2	5.68	77.6	3.06	19.6	0.77	130.5	5.14	41.3	1.63
1W12FHB16.150	3/4"	-16	141.8	5.58	75.2	2.96	19.6	0.77	150.0	5.91	41.3	1.63
1W16FHB16	1"	-16	155.6	6.13	89.0	3.50	19.6	0.77	71.0	2.80	47.7	1.88
1W16FHB16.061	1"	-16	144.2	5.68	77.6	3.06	19.6	0.77	61.0	2.40	47.6	1.87
1W16FHB16.075	1"	-16	155.6	6.13	89.0	3.50	19.6	0.77	75.0	2.95	47.7	1.88
1W16FHB16.080	1"	-16	155.6	6.13	89.0	3.50	19.6	0.77	80.0	3.15	47.7	1.88

# FHB

SAE Flange Code 62, 90° Elbow (FHB)

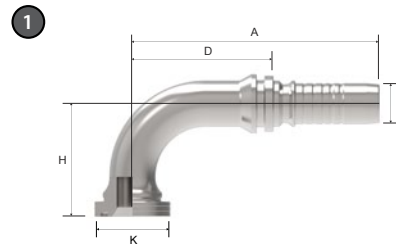

PART	HOSE SIZE INFO		DIMENSIONS									
	1W part #	Flange size	Hose size	A		D		EØ		H		KØ
			mm	in	mm	in	mm	in	mm	in	mm	in
<b>1W16FHB16.086</b>	1"	-16	155.6	6.13	89.0	3.50	19.6	0.77	86.0	3.39	47.6	1.87
<b>1W16FHB16.100</b>	1"	-16	155.5	6.12	88.9	3.50	19.6	0.77	100.0	3.94	47.6	1.87
<b>1W16FHB16.110</b>	1"	-16	155.6	6.13	89.0	3.50	19.6	0.77	110.0	4.33	47.6	1.87
<b>1W16FHB16.120</b>	1"	-16	155.6	6.13	89.0	3.50	19.6	0.77	120.0	4.72	47.6	1.87
<b>1W16FHB16.130</b>	1"	-16	155.5	6.12	89.0	3.50	19.6	0.77	130.0	5.12	47.6	1.87
<b>1W16FHB16.140</b>	1"	-16	165.1	6.50	98.5	3.88	19.6	0.77	140.0	5.51	47.7	1.88
<b>1W16FHB16.150</b>	1"	-16	155.1	6.11	88.5	3.48	19.6	0.77	150.0	5.91	47.6	1.87
<b>1W16FHB16.175</b>	1"	-16	181.0	7.13	114.4	4.50	20.0	0.79	175.0	6.89	47.6	1.87
<b>1W16FHB16.180</b>	1"	-16	181.2	7.13	114.6	4.51	20.0	0.79	180.0	7.09	47.6	1.87
<b>1W16FHB16.260</b>	1"	-16	181.1	7.13	114.5	4.51	20.0	0.79	260.0	10.24	47.6	1.87
<b>1W16FHB16.270</b>	1"	-16	181.2	7.13	114.6	4.51	20.0	0.79	270.0	10.63	47.6	1.87
<b>1W16FHB16.280</b>	1"	-16	181.2	7.13	114.6	4.51	19.6	0.77	280.0	11.02	47.6	1.87
<b>1W16FHB16.320</b>	1"	-16	181.2	7.13	114.5	4.51	19.6	0.77	320.0	12.60	47.6	1.87
<b>1W16FHB16.414</b>	1"	-16	181.1	7.13	114.5	4.51	20.0	0.79	414.0	16.30	47.6	1.87
<b>1W20FHB16</b>	1 1/4"	-16	174.7	6.88	108.0	4.25	19.6	0.77	89.0	3.50	54.0	2.13
<b>1W20FHB16.074</b>	1 1/4"	-16	148.6	5.85	82.0	3.23	20.0	0.79	74.0	2.91	54.0	2.13
<b>1W20FHB16.100</b>	1 1/4"	-16	174.7	6.88	108.0	4.25	19.6	0.77	100.0	3.94	54.0	2.13
<b>1W20FHB16.120</b>	1 1/4"	-16	174.7	6.88	108.0	4.25	19.6	0.77	120.0	4.72	54.0	2.13
<b>1W20FHB16.180</b>	1 1/4"	-16	149.0	5.87	82.4	3.24	19.6	0.77	180.0	7.09	54.0	2.13
<b>1W20FHB16.260</b>	1 1/4"	-16	181.1	7.13	114.5	4.51	20.0	0.79	260.0	10.24	54.0	2.13

## Spiral - 1W series

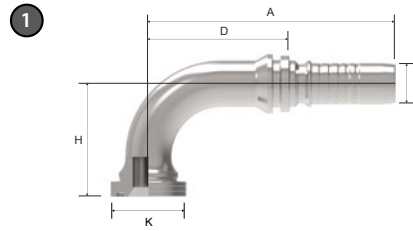

# FHB

SAE Flange Code 62, 90° Elbow (FHB)

PART	HOSE SIZE INFO		DIMENSIONS									
	Flange size	Hose size	A		D		EØ		H		KØ	
1W part #			mm	in	mm	in	mm	in	mm	in	mm	in
1W20FHB16.320	1 1/4"	-16	149.1	5.87	82.4	3.24	19.6	0.77	320.0	12.60	54.0	2.13
1W16FHB20.120	1"	-20	159.0	6.26	84.1	3.31	25.5	1.00	120.0	4.72	47.6	1.87
1W16FHB20	1"	-20	176.0	6.93	101.1	3.98	25.5	1.00	75.0	2.95	47.6	1.87
1W20FHB20	1 1/4"	-20	185.0	7.28	110.1	4.33	25.5	1.00	89.0	3.50	54.0	2.13
1W20FHB20.066	1 1/4"	-20	158.5	6.24	83.6	3.29	25.5	1.00	66.5	2.62	54.0	2.13
1W20FHB20.083	1 1/4"	-20	171.9	6.77	97.0	3.82	25.5	1.00	83.4	3.28	54.0	2.13
1W20FHB20.100	1 1/4"	-20	185.0	7.28	110.1	4.33	25.5	1.00	100.0	3.94	54.0	2.13
1W20FHB20.120	1 1/4"	-20	185.0	7.28	110.1	4.33	25.5	1.00	120.0	4.72	54.0	2.13
1W20FHB20.150	1 1/4"	-20	185.0	7.28	110.0	4.33	25.5	1.00	150.0	5.91	54.0	2.13
1W20FHB20.170	1 1/4"	-20	168.5	6.63	93.6	3.69	25.5	1.00	170.0	6.69	54.0	2.13
1W24FHB20	1 1/2"	-20	213.1	8.39	138.2	5.44	25.5	1.00	115.0	4.53	63.5	2.50
1W24FHB20.085	1 1/2"	-20	168.5	6.63	93.6	3.69	25.5	1.00	85.0	3.35	63.5	2.50
1W24FHB20.120	1 1/2"	-20	168.5	6.63	93.6	3.69	25.5	1.00	120.0	4.72	63.5	2.50
1W24FHB20.140	1 1/2"	-20	168.5	6.63	93.6	3.69	25.5	1.00	140.0	5.51	63.5	2.50
1W20FHB24.085	1 1/4"	-24	195.0	7.68	96.5	3.80	30.0	1.18	84.7	3.33	54.0	2.13
1W20FHB24.120	1 1/4"	-24	222.0	8.74	123.5	4.86	30.0	1.18	120.0	4.72	54.0	2.13
1W20FHB24.165	1 1/4"	-24	226.0	8.90	127.5	5.02	30.0	1.18	165.0	6.50	54.0	2.13
1W24FHB24	1 1/2"	-24	234.0	9.21	135.5	5.33	30.0	1.18	115.0	4.53	63.5	2.50
1W24FHB24.085	1 1/2"	-24	190.0	7.48	91.5	3.60	30.0	1.18	85.0	3.35	63.5	2.50
1W24FHB24.120	1 1/2"	-24	190.0	7.48	91.5	3.60	30.0	1.18	120.0	4.72	63.5	2.50
1W24FHB24.140	1 1/2"	-24	234.0	9.21	135.5	5.33	30.0	1.18	140.0	5.51	63.5	2.50
1W24FHB24.165	1 1/2"	-24	234.0	9.21	135.5	5.33	30.0	1.18	165.0	6.50	63.5	2.50
1W32FHB24.140	2"	-24	234.0	9.21	135.5	5.33	30.0	1.18	140.0	5.51	79.4	3.13
1W32FHB32.150	2"	-32	281.6	11.09	173.2	6.82	42.1	1.66	150.0	5.91	79.4	3.13

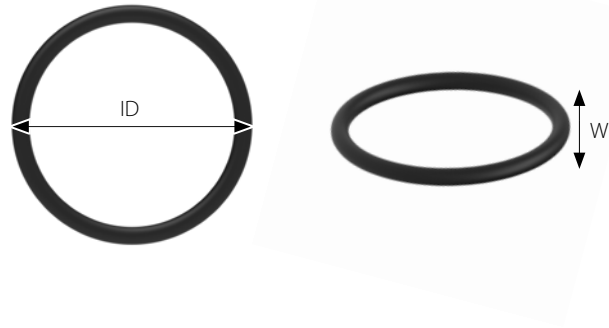

## O-Rings

for ISC type 1W fittings (-20, -24, -32)

Part number	Hose size	W (mm)	ID (mm)
05.071-27.30x2.40	-20	2.40	27.30
05.071-32.99x2.62	-24	2.62	32.99
05.071-44.12x2.62	-32	2.62	44.12

\*O-rings must be ordered separately.

\*\*Two (2) O-Rings are required for one nipple.

\*\*\*O-rings must be installed with PAG oil (only) prior to crimping.



## Hose to fitting chart

# 1W sockets

Sockets for 1W fittings

Part 1 1W part #	Hose size info		Dimensions			
	DN	Hose size	L		OD	
			mm	in	mm	in
<b>1WA12</b>	20	-12	52.1	2.05	43.1	1.70
<b>1WA16</b>	25	-16	66.5	2.62	48.8	1.92
<b>1WA20</b>	31	-20	77.7	3.06	57.2	2.25
<b>1WA24</b>	38	-24	96.6	3.80	65.4	2.57
<b>1WA32</b>	51	-32	107.1	4.22	80.0	3.15
<b>1WB20</b>	31	-20	78.7	3.10	62.0	2.44
<b>1WB24</b>	38	-24	96.6	3.80	70.6	2.78
<b>1WB32</b>	51	-32	107.1	4.22	87.6	3.45
<b>1WD10</b>	16	-10	49.1	1.93	35.9	1.41
<b>1WD12</b>	20	-12	57.0	2.24	42.1	1.66
<b>1WD16</b>	25	-16	67.5	2.66	51.4	2.02
<b>1WE20</b>	31	-20	78.7	3.10	63.5	2.50
<b>1WC20</b>	31	-20	79.2	3.12	58.0	2.28

## Socket type by hose

Part	Dimensions
Hose part #	Socket
<b>EC600-12</b>	1WD12
<b>EC600-16</b>	1WD16
<b>EC600-20</b>	1WE20
<b>EC600-24</b>	1WB24
<b>EC600-32</b>	1WB32
<b>EC810-12</b>	1WA12
<b>EC810-16</b>	1WA16
<b>EC810-20</b>	1WB20
<b>EC810-24</b>	1WB24
<b>EC810-32</b>	1WB32
<b>EC850-10</b>	1WD10
<b>EC850-12</b>	1WD12
<b>EC850-16</b>	1WD16
<b>EC850-20</b>	1WE20
<b>EC910-12</b>	1WA12
<b>EC910-16</b>	1WA16
<b>GH466-20</b>	1WB20
<b>GH466-24</b>	1WB24
<b>GH466-32</b>	1WB32
<b>GH506-12</b>	1WA12
<b>GH506-16</b>	1WA16
<b>GH506-20</b>	1WA20
<b>GH506-24</b>	1WA24
<b>GH506-32</b>	1WA32
<b>GH507-20</b>	1WC20

Danfoss

## Hose accessories



## Hose accessories

## GA7000555

### Plastic protective coil sleeve



Recommended to protect hose from abrasion this plastic sleeve is unaffected by air water, oil, gasoline and hydraulic fluids. Temperature ranger between -18°C to +82°C (-0.4°F to +180°F).

GA7000555		
Part number	Sleeve I.D.	
	mm	in
GA700555-6	9.5	0.37
GA700555-8	12.5	0.49
GA700555-10	16	0.63
GA700555-12	19	0.75
GA700555-16	25.4	1
GA700555-22	32	1.34

## 900705

### Steel protective coil sleeve



Recommended for use where hose lines are subjected to excessive abrasion, kinking or accidental damage. Construction: spring steel, rust resistant. This coil should fit snugly to the hose O.D. expanding the coil I.D. (unwind the coil) may be necessary for proper installation.

900705		
Sleeve dash no	Sleeve I.D.	
	mm	in
-17S	11.2	0.44
-1S	12.7	0.50
-13S	14.5	0.57
-2S	16.0	0.63
-3S	19.0	0.75
-4S	22.3	0.88
-5S	26.2	1.03
-14S	28.7	1.13
-6S	31.0	1.22
-7S	37.3	1.47
-9S	42.9	1.69
-8S	48.5	1.91
-10S	54.1	2.13
-16S	62.0	2.44
-11S	65.0	2.56

## GA7000696

### Plastic protective coil spring



Recommended to protect hose from abrasion, this light weight plastic sleeve is unaffected by air, water, oil, gasoline, hydraulic and most other fluids. This coil can also be used for group bundling of hose lines. Celsius range of -20°C to +82°C (-4°F to +180°F).

GA7000696		
Sleeve dash no	Sleeve I.D.	
	mm	in
GA7000696-6	9.5	0.37
GA7000696-8	13	0.51
GA7000696-10	16	0.63
GA7000696-12	19	0.75
GA7000696-16	25	0.98
GA7000696-22	35	1.38
GA7000696-30	50	1.97
GA7000696-64	100	3.94

## 900564

### Steel protective coil spring



Protects hose cover and reinforcement from abrasion and accidental damage. Construction; steel wire, rust resistant. This coil should fit snugly to the hose O.D. expanding the coil I.D. (unwind the coil) may be necessary for proper installation.

900564		
Part number	Sleeve I.D.	
	mm	in
900564-1S	15.5	0.610
900564-12S	16.8	0.660
900564-2S	19.1	0.750
900564-14S	21.3	0.840
900564-3S	23.1	0.910
900564-4S	26.6	1.048
900564-5S	30.0	1.180
900564-6S	34.0	1.340
900564-7S	41.7	1.642
900564-9S	47.8	1.880
900564-8S	54.0	2.125
900564-10S	60.5	2.380
900564-11S	73.0	2.875

## 624

### Firesleeve



Firesleeve will protect hose from direct flame. Firesleeve is constructed of a uniform single layer of braided fiberglass tubing impregnated with flame resistant silicone rubber. Temperature range of -53.8°C to +260°C (-65°F to +500°F).

624		
Part #	Nominal Sleeve I.D.* "B"	
	mm	in
624-5	7.9	0.31
624-7	11.2	0.44
624-8	12.7	0.50
624-9	14.2	0.56
624-10	15.7	0.62
624-11	17.5	0.69
624-12	19.0	0.75
624-13	20.6	0.81
624-14	22.3	0.88
624-16	25.4	1.00
624-18	28.4	1.12
624-20	31.7	1.25
624-22	35.0	1.38
624-24	38.1	1.50
624-26	41.1	1.62
624-28	44.4	1.75
624-30	47.7	1.88
624-32	50.8	2.00
624-38	60.4	2.38
624-42	66.5	2.62
624-46	73.1	2.88
624-50	79.2	3.12
624-54	85.8	3.38
624-60	95.2	3.75

## FC425

### Nylon abrasion sleeve meets MSHA requirements



Nylon sleeve protects hose from abrasion and allows bundling of hose lines.

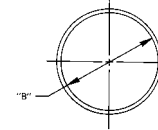

FC425		
Part #	Nominal Sleeve I.D.* "B"	
	mm	in
FC425-12	18.0	0.71
FC425-16	25.4	1.00
FC425-18	28.7	1.13
FC425-20	31.7	1.25
FC425-24	40.4	1.59
FC425-28	44.4	1.75
FC425-32	52.6	2.07
FC425-38	60.4	2.38
FC425-40	64.5	2.54
FC425-46	72.6	2.86
FC425-54	84.8	3.34
FC425-59	93.0	3.66

\*The maximum O.D. of hose fittings must be allowed for if fittings are to be covered.

## 900729

### Support clamp

These lightweight vinyl-coated steel support clamps are designed to support hose where long runs are necessary.

This clamp not only furnishes a cleaner installation, but prevents damage, exposure and chafing. The lining will withstand high ambient temperatures. Bolt hole dia: Clamp dash no. -01 thru -8, -18 thru -23 is M10; -9 thru -17, -24 thru -31 is M12.

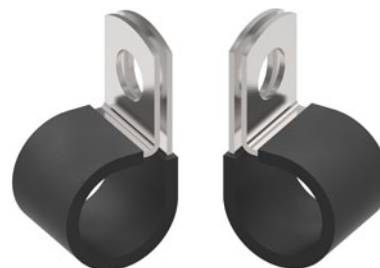

## Hose accessories

# FF90754

## Guardian sleeve

**Denier:** 1260

**Melting Point:** 215°C/420°F

**Material:** Polyamide 6, made with pre-dyed yarn

**Dim. Stability:** Great resistance to sun, atmospheric agents and aging

**Toxicity:** Non-Toxic

**Color:** Black

**Packing Requirements:** Danfoss Guardian Sleeve comes in a 94.1 m (300 foot) roll with no more than 3 cuts per roll and no piece shorter than 9.1 m (30 feet). Note must be ordered by the roll.

### Properties and specifications

Properties	Specification	Description
Burst pressure	1,103 bar (16,000psi)	Capable to contain hose burst up to 1,103 bar (16,000psi)
Pin hole leak pressure	275 bar (4,000 psi)	Sustained 275 bar (4,000 psi) pin hole deflection from focused 1mm pin hole
Abrasion cycles	250,000	Holds up to 250,000 abrasion cycles per ISO 6945

### General and dimensional information

Part #	Nominal I.D. (mm)	Nominal I.D. (in)	A – Flat width (mm) +/- 3.75	A – Flat width (in) +/- 0.125	Weights in lbs per 94.1m (300 Ft) Roll	Rolls per box
FF90754-68	17.27	0.68	32.77	1.290	7.43	8
FF90754-79	20.07	0.79	35.56	1.400	8.50	7
FF90754-91	23.11	0.91	40.39	1.590	9.70	6
FF90754-98	24.89	0.98	40.39	1.590	10.13	6
FF90754-106	26.92	1.06	46.36	1.825	11.10	5
FF90754-122	30.99	1.22	52.73	2.076	12.60	4
FF90754-142	36.07	1.42	60.71	2.390	14.50	4
FF90754-157	39.88	1.57	67.31	2.650	16.10	3
FF90754-173	43.94	1.73	73.91	2.910	17.70	3
FF90754-185	46.99	1.85	78.74	3.100	18.80	3
FF90754-209	53.09	2.09	88.14	3.470	21.10	2
FF90754-219	55.63	2.19	92.20	3.630	22.10	2
FF90754-238	60.45	2.38	99.70	3.925	23.90	2
FF90754-288	73.15	2.88	119.74	4.714	28.60	2
FF90754-366	92.96	3.66	150.83	5.938	36.10	1

### Guardian sleeve chemical compatibility

Chemical	Compatibility
Gasoline	Very Good
Oil	Very Good
Mineral and vegetable oil	Very Good
Ionic metallic solutions	Very Good
Alcohols	Very Good
Diluted bases	Very Good
Diluted acids *	Good
Benzene	Very Good
Acetone	Very Good
Ether	Very Good
Carbon Tetrachloride	Very Good
Chlorine based solvent	Very Good
Mold, bacteria, moths	Very Good

\*Strong and concentrated acids; ie. HCl or Formic acid may have some corrosive action.

### Guardian sleeve selection chart

Suggested sleeve part #	Sleeve I.D. (mm)	Sleeve I.D. (in)	Max hose OD that sleeve can accept (mm)	Max hose OD that sleeve can accept (in)	Hose size as a ref.
FF90754-68	17.27	0.68	13.21	0.52	-4
FF90754-79	20.07	0.79	15.49	0.61	-4
FF90754-91	23.11	0.91	17.78	0.70	-6
FF90754-98	24.89	0.98	19.30	0.76	-6
FF90754-106	26.92	1.06	20.32	0.80	-6
FF90754-122	30.99	1.22	23.37	0.92	-8
FF90754-142	36.07	1.42	25.91	1.02	-10
FF90754-157	39.88	1.57	28.70	1.13	-10
FF90754-173	43.94	1.73	31.50	1.24	-12
FF90754-185	46.99	1.85	34.04	1.34	-16
FF90754-209	53.09	2.09	38.10	1.50	-16
FF90754-219	55.63	2.19	39.12	1.54	-20
FF90754-238	60.45	2.38	43.18	1.70	-20
FF90754-288	73.15	2.88	50.80	2.00	-20
FF90754-366	92.96	3.66	60.96	2.40	-24

### Assembly instructions

- Select the correct sleeve part number for the Hose as outlined in the Table 2.
- Cut the sleeve 2 inches longer than the cut length of the hose to allow full hose bend radius.
- The ends of the sleeves must be seared to prevent sleeve from fraying.
- Slide the sleeve over the hose.
- Properly assemble the hose ends.
- Secure the sleeve over hose sockets with a metal banding product.



# Flaretite® seals

The ideal product to enhance new installations of SAE 37° connections, as well as seal off minor leaks and weeping connections.



### Features:

- Ribbed insert design
- Coated with Loctite sealant
- Economical method to reduce minor leaks and weeping connections
- Built-in clip to attach the Flaretite seal to the nose of the SAE 37 degree connection
- Available sizes: -04 through -32

### Benefits:

- Multiple surface contact points
- Locks the joint and fills surface imperfections
- Saves time & money associated with maintenance and rework
- Quick & easy assembly

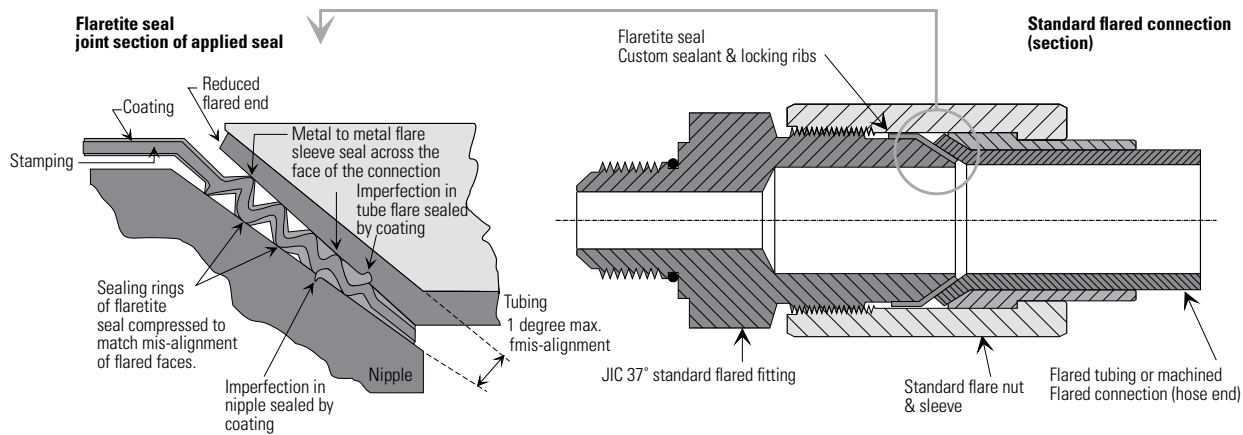

### Properties and specifications

Properties	Specification	Description
Burst pressure	1,103 bar (16,000psi)	Capable to contain hose burst up to 1,103 bar (16,000psi)
Pin hole leak pressure	275 bar (4,000 psi)	Sustained 275 bar (4,000 psi) pin hole deflection from focused 1mm pin hole
Abrasion cycles	250,000	Holds up to 250,000 abrasion cycles per ISO 6945

### Assembly and torque requirements

To assemble an SAE 37° connection using a Flaretite seal, simply push the Flaretite seal onto the male portion of the connection. The built-in clip will hold the Flaretite seal onto the male half.

#### During assembly ensure:

- The seal is fitted squarely to the conical nose of the JIC fitting -37° flare.
- The sealing faces of the flared connector part are clean and free of burrs.
- The flared joint is correctly tightened with recommended torque settings noted below.

### Recommended torque settings:

Tolerance: +10% -0%







-04 (1/4")	SAE 37°: 19 N-m	-10 (5/8")	SAE 37°: 109 N-m	-20 (1-1/4")	SAE 37°: 258 N-m
-06 (3/8")	SAE 37°: 25 N-m	-12 (3/4")	SAE 37°: 149 N-m	-24 (1-1/2")	SAE 37°: 298 N-m
-08 (1/2")	SAE 37°: 75 N-m	-16 (1")	SAE 37°: 190 N-m	-32 (2")	SAE 37°: 440 N-m







\* Flaretite is a registered trademark of Flaretite Inc.

All photos and the name Flaretite are the property of Flaretite Inc.

\*\* Loctite is a registered trademark of the Henkel Corporation.







## Hose accessories







	900564	900705	GA7000555	GA7000696	624	FC425	900729
	Steel protective coil spring*	Steel protective coil sleeve*	Plastic protective coil sleeve*	Plastic protective coil spring*	Firesleeve*	Nylon abrasion sleeve*	Support clamp*
Hose part #							
GH681(B)-3	-1S	-13S	-6	-6	-9	-12	-2
GH681(B)-4	-1S	-2S	-8	-8	-10	-12	-21
GH681(B)-5	-12S	-3S	-8	-8	-11	-12	-3
GH681(B)-6	-2S	-3S	-10	-10	-13	-15	-4
GH681(B)-8	-3S	-5.1	-10		-16	-16	-6
GH681(B)-10	-4S	-5.1	-12		-18	-18	-23
GH681(B)-12	-5S	-6S	-16	-16	-20		-9
GH681(B)-16	-7S	-9S		-22	-24	-28	-10
GH681(B)-20	-9S	-8S			-30	-32	-12
GH681(B)-24	-10S	-10S			-36	-38	-29
GH681(B)-32	-11S				-46	-54	-15
EC881(B)-4	-12S	-3S	-8	-8	-11	-12	-21
EC881(B)-5	-2S	-3S	-10	-10	-12	-15	-4
EC881(B)-6	-14S	-4S	-10	-10	-14	-15	-5
EC881(B)-8	-4S	-5.1	-12		-16	-18	-23
EC881(B)-10	-5S	-14S	-12	-12	-18	-20	-8
EC881(B)-12	-6S	-6S	-16	-16	-20	-24	-24
EC881(B)-16	-7S	-9S	-22	-22	-26	-28	-11
EC881(B)-20	-8S	-8S		-30	-30	-32	-28
EC881(B)-24	-10S	-11S			-36	-38	-14
EC881(B)-32	-11S	-12S			-46	-54	-15
GH781-4	-12S	-2S	-8	-8	-11	-12	-21
GH781-5	-2S	-3S	-10	-10	-12	-15	-4
GH781-6	-14S	-4S	-10	-10	-14	-15	-5
GH781-8	-4S	-5.1	-12		-16	-18	-23
GH781-10	-5S	-14S	-12	-12	-18	-20	-8
GH781-12	-6S	-6S	-16	-16	-22	-24	-24
GH781-16	-7S	-9S	-22	-22	-26	-28	-11
GH781-20	-8S	-8S		-30	-32	-32	-28
GH781-24	-10S	-11S			-36	-38	-14
GH781-32	-11S	-12S			-46	-54	-15
GH425(B)-6	-4S	-5.1	-12		-16	-16	-6
GH425(B)-8	-5S	-14S	-12	-12	-18	-20	-8
GH425(B)-10	-6S	-6S	-16	-16	-20	-24	-27
GH425(B)-12	-7S	-7S			-24	-24	-10
GH425(B)-16	-9S	-8S			-28	-32	-12
GH506-12	-7S	-7S			-24	-24	-10
GH506-16	-9S	-8S			-28	-32	-12
GH506-20	-8S	-10S		-30	-32	-38	-13
GH506-24	-10S	-11S			-38	-40	-14
GH506-32					-48	-54	-16
FC500-12	-7S	-7S			-24	-24	-10
FC500-16	-9S	-9S	-22		-28	-32	-12
FC500-20	-8S	-10S		-30	-32	-38	-13
FC500-24	-10S	-11S			-38	-40	-14

	900564	900705	GA7000555	GA7000696	624	FC425	900729
	Steel protective coil spring*	Steel protective coil sleeve*	Plastic protective coil sleeve*	Plastic protective coil spring*	Firesleeve*	Nylon abrasion sleeve*	Support clamp*
Hose part #							
FC500-32					-50	-54	
GH466-20	-10S	-11S			-36	-38	-14
GH466-24		-11S			-40	-46	-30
GH466-32					-50	-54	
EC600-12	-7S	-7S			-24	-24	-10
EC600-16	-9S	-9S			-28	-32	-12
EC600-20	-10S	-10S			-36	-38	-14
EC600-24		-11S			-40	-46	-30
EC600-32					-50	-54	
FC510-4	-2S	-3S	-8	-8	-11	-15	-3
FC510-6	-14S	-4S	-10	-10	-14	-15	-5
FC510-8	-4S	-5.1	-12		-16	-16	-6
FC510-10	-5S	-14S	-12	-12	-18	-20	-8
FC510-12	-6S	-6S	-16	-16	-22	-24	-27
FC510-16	-7S	-9S	-22	-22	-26	-28	-10
FC510-20	-8S	-8S		-30	-30	-32	-28
GH195-4	-2S	-3S	-8	-10	-12	-15	-4
GH195-6	-3S	-4S			-16	-16	-6
GH195-8	-4S	-5.1	-12		-16	-18	-23
GH195-10	-5S	-6S	-16	-12	-20	-20	-9
GH195-12	-6S	-7S	-16	-16	-22	-24	-25
GH195-16	-9S	-9S	-22		-28	-32	-12
GH195-20	-8S	-10S			-36	-38	-13
GH195-24	-10S	-11S			-38	-40	-30
GH195-32	-11S	-12S			-46	-54	-16
EC525-12	-7S	-7S			-24	-24	-25
EC525-16	-9S	-9S	-22		-28	-32	-12
EC525-20	-8S	-10S			-36	-38	-13
EC525-24	-10S	-11S			-38	-40	-14
EC525-32	-11S				-46	-54	-16
GH120-4	-12S	-3S	-8	-8	-11	-12	-35
GH120-6	-14S	-4S	-10	-10	-14	-15	-5
GH120-8	-4S	-5.1	-12		-16	-18	-23
GH120-10	-5S	-6S	-16	-12	-18	-20	-9
GH120-12	-6S	-7S	-16	-16	-22	-24	-24
GH120-16	-7S	-9S	-22	-22	-26	-28	-11
GH120-20	-8S	-10S		-30	-32	-32	-28
GH120-24	-10S	-11S			-36	-38	-14
GH120-32	-11S				-46	-54	-15
EC810-6	-4S	-5.1	-12		-16	-18	-23
EC810-8	-5S	-14S	-16	-12	-18	-20	-8
EC810-10	-6S	-7S	-16	-16	-22	-24	-24
EC810-12	-7S	-7S			-24	-24	-10
EC810-16	-9S	-8S			-28	-32	-12
EC810-20	-10S	-10S			-36	-38	-29
EC810-24		-11S			-40	-46	-30
EC810-32					-50	-54	
EC115-4	-12S	-2S	-8	-8	-10	-12	-21

















## Hose accessories

	900564	900705	GA7000555	GA7000696	624	FC425	900729
	Steel protective coil spring*	Steel protective coil sleeve*	Plastic protective coil sleeve*	Plastic protective coil spring*	Firesleeve*	Nylon abrasion sleeve*	Support clamp*
Hose part #							
EC115-5	-12S	-3S	-8	-8	-11	-12	-35
EC115-6	-14S	-3S	-10	-10	-13	-15	-5
EC115-8	-3S	-5.1	-12		-16	-16	-6
EC115-10	-4S	-5.1	-12		-18	-18	-23
EC115-12	-5S	-6S	-16	-16	-20	-20	-9
EC115-16	-7S	-9S		-22	-26	-28	-10
EC115-20	-9S	-8S			-30	-32	-12
EC115-24	-8S	-10S			-36	-38	-13
EC115-32	-11S	-12S			-42	-46	-31
EC110-4	-12S	-2S	-8	-8	-11	-12	-21
EC110-5	-2S	-3S	-8	-10	-12	-15	-4
EC110-6	-14S	-4S	-10	-10	-13	-15	-5
EC110-8	-4S	-5.1	-12		-16	-16	-6
EC110-10	-5S	-14S	-12	-12	-18	-20	-8
EC110-12	-6S	-7S	-16	-16	-22	-24	-27
EC110-16	-7S	-9S	-22	-22	-26	-28	-11
EC110-20	-8S	-10S		-30	-32	-32	-13
EC110-24	-10S	-11S			-36	-38	-14
EC110-32	-11S	-12S			-46	-54	-15
EC215-4	-12S	-2S	-8	-8	-11	-12	-21
EC215-5	-2S	-3S	-10	-10	-12	-15	-4
EC215-6	-14S	-4S	-10	-10	-14	-15	-5
EC215-8	-4S	-5.1	-12		-16	-18	-23
EC215-10	-5S	-14S	-12	-12	-18	-20	-8
EC215-12	-6S	-7S	-16	-16	-22	-24	-27
EC215-16	-7S	-9S	-22	-22	-26	-28	-10
EC215-20	-8S	-10S		-30	-32	-32	-13
EC215-24	-10S	-11S			-36	-38	-14
EC215-32	-11S	-12S			-46	-54	-31
EC210-4	-2S	-3S	-8	-10	-12	-15	-4
EC210-5	-14S	-4S	-10	-10	-13	-15	-5
EC210-6	-3S	-4S			-16	-16	-6
EC210-8	-4S	-5.1	-12		-18	-18	-23
EC210-10	-5S	-6S	-16	-12	-20	-20	-9
EC210-12	-6S	-7S	-16	-16	-22	-24	-25
EC210-16	-9S	-9S	-22		-28	-32	-12
EC210-20	-10S	-10S			-36	-38	-29
EC210-24	-10S	-11S			-38	-40	-30
EC210-32	-11S				-46	-54	-16
EC426-6	-4S	-5.1	-12		-16	-18	-23
EC426-8	-5S	-6S	-16	-12	-20	-20	-8
EC426-10	-6S	-7S	-16	-16	-22	-24	-24
EC426-12	-7S	-7S			-24	-24	-10
EC426-16	-9S	-8S			-30	-32	-12
EC426-20		-10S			-36	-38	-13
EC512-12	-7S	-7S			-24	-24	-10







	900564	900705	GA7000555	GA7000696	624	FC425	900729
	Steel protective coil spring*	Steel protective coil sleeve*	Plastic protective coil sleeve*	Plastic protective coil spring*	Firesleeve*	Nylon abrasion sleeve*	Support clamp*
Hose part #							
EC512-16	-9S	-8S			-28	-32	-12
EC512-20	-8S	-10S		-30	-32	-38	-13
EC512-24	-10S	-11S			-38	-40	-14
EC512-32	-11S				-48	-54	-16
EC420-12	-7S	-7S			-24	-24	-10
EC420-16	-9S	-8S			-28	-32	-12
EC420-20	-10S	-10S			-36	-38	-14
EC420-24		-11S			-40	-46	-30
EC420-32					-50	-54	
EC615-12							
EC615-16	-9S	-8S			-28	-32	-12
EC615-20	-10S	-10S			-36	-38	-14
EC615-24		-11S			-40	-46	-30
EC615-32							
GH585-3	-1S	-13S	-6		-10	-12	-21
GH585-4	-12S	-2S	-8	-8	-11	-12	-21
GH585-5	-2S	-3S	-8	-10	-12	-15	-4
GH585-6	-14S	-4S	-10	-10	-14	-15	-5
GH585-8	-3S	-5.1	-12		-16	-16	-6
GH585-10	-5S	-14S		-12	-18	-20	-8
GH585-12	-6S	-6S	-16	-16	-22	-24	-27
GH585-16	-7S	-9S	-22	-22	-26	-28	-11
EC109-4	-12S	-3S	-8	-8	-11	-12	-21
EC109-5	-2S	-3S	-8	-10	-12	-15	-4
EC109-6	-14S	-4S	-10	-10	-14	-15	-5
EC109-8	-4S	-5.1	-12		-16	-16	-6
EC109-10	-5S	-14S	-12	-12	-18	-20	-8
EC109-12	-6S	-6S	-16	-16	-22	-24	-27
EC109-16	-7S	-9S	-22	-22	-26	-28	-11
EC112-4	-1S	-2S	-8	-8	-10	-12	-21
EC112-5	-12S	-3S	-8	-8	-11	-12	-35
EC112-6	-14S	-3S	-10	-10	-13	-15	-5
EC112-8	-3S	-4S	-10		-16	-16	-6
EC112-10	-4S	-5.1	-12		-18	-18	-23
EC112-12	-5S	-6S	-16	-16	-20	-20	-9
EC112-16	-7S	-9S		-22	-26	-28	-10
EC209-4	-2S	-3S	-8	-10	-12	-15	-4
EC209-5	-14S	-4S	-10	-10	-13	-15	-5
EC209-6	-3S	-4S	-10		-16	-16	-6
EC209-8	-4S	-5.1	-12		-18	-18	-23
EC209-10	-5S	-6S	-16	-12	-20	-20	-9
EC209-12	-6S	-7S	-16	-16	-22	-24	-25

## Hose accessories

	900564	900705	GA7000555	GA7000696	624	FC425	900729
	Steel protective coil spring*	Steel protective coil sleeve*	Plastic protective coil sleeve*	Plastic protective coil spring*	Firesleeve*	Nylon abrasion sleeve*	Support clamp*
Hose part #							
EC209-16	-9S	-9S	-22		-28	-32	-12
EC212-4	-12S	-3S	-8	-8	-11	-12	-21
EC212-5	-2S	-3S	-10	-10	-13	-15	-4
EC212-6	-14S	-4S	-10	-10	-14	-15	-5
EC212-8	-4S	-5.1	-12		-16	-18	-23
EC212-10	-5S	-14S	-12	-12	-18	-20	-8
EC212-12	-6S	-6S	-16	-16	-22	-24	-27
EC212-16	-7S	-9S	-22	-22	-26	-28	-11
EC212-20	-8S	-10S		-30	-32	-32	-13
EC212-24	-10S	-11S			-36	-38	-14
EC212-32	-11S				-46	-54	-31
EC045-3	-1S	-13S	-6		-10	-12	-2
EC045-4	-12S	-2S	-8	-8	-11	-12	-21
EC045-5	-2S	-3S	-8	-10	-12	-15	-4
EC045-6	-14S	-4S	-10	-10	-14	-15	-5
EC045-8	-3S	-5.1	-12		-16	-16	-23
EC045-10	-5S	-14S		-12	-18	-20	-8
EC045-12	-6S	-6S	-16	-16	-20	-24	-27
EC045-16	-7S	-9S	-22	-22	-26	-28	-10
EC116-4	-1S	-2S	-8	-8	-10	-12	-21
EC116-5	-12S	-3S	-8	-8	-11	-12	-35
EC116-6	-2S	-3S	-10	-10	-12	-15	-4
EC116-8	-3S	-4S	-10		-16	-16	-6
EC216-4	-12S	-3S	-8	-8	-11	-12	-21
EC216-5	-2S	-3S	-8	-10	-12	-15	-4
EC216-6	-14S	-4S	-10	-10	-14	-15	-5
EC216-8	-4S	-5.1	-12		-16	-18	-23
EC910-8	-5S	-14S	-16	-12	-20	-20	-8
EC910-12	-7S	-7S			-24	-24	-10
EC910-16	-9S	-8S			-28	-32	-12
FC310-3	-1S	-13S	-6		-10	-12	-2
FC310-4	-12S	-3S	-8	-8	-11	-15	-3
FC310-5	-2S	-3S	-8	-10	-12	-15	-4
FC310-6	-14S	-4S	-10	-10	-13	-15	-5
FC310-8	-4S	-5.1	-12		-16	-16	-6
FC310-10	-5S	-14S	-12	-12	-18	-20	-8
FC310-12	-6S	-6S	-16	-16	-22	-24	-27
FC310-16	-7S	-9S	-22	-22	-26	-28	-10
FC310-20	-8S	-10S		-30	-32	-32	-28
SH222-4	-2S	-3S	-8	-10	-12	-15	-4
SH222-6	-3S	-4S			-16	-16	-6
SH222-8	-4S	-5.1	-12		-18	-18	-23

	900564	900705	GA7000555	GA7000696	624	FC425	900729
	Steel protective coil spring*	Steel protective coil sleeve*	Plastic protective coil sleeve*	Plastic protective coil spring*	Firesleeve*	Nylon abrasion sleeve*	Support clamp*
Hose part #							
SH222-12	-6S	-7S	-16		-22	-24	-25
SH222-16	-7S	-9S	-22	-22	-26	-28	-11
EC330-6	-3S	-4S	-12		-16	-16	-6
EC330-8	-4S	-5.1	-12		-16	-18	-23
EC330-10	-5S	-6S	-16	-12	-20	-20	-9
EC330-12	-6S	-7S	-16	-16	-22	-24	-25
EC850-10	-6S	-7S	-16	-16	-22	-24	-24
EC850-12	-7S	-7S			-24	-24	-10
EC850-16	-9S	-8S			-28	-32	-12
EC850-20	-10S	-10S			-36	-38	-14
GH435-6	-3S	-4S	-10		-16	-16	-6
GH435-8	-4S	-5.1	-12		-16	-18	-23
GH435-10	-5S	-6S	-16	-12	-20	-20	-9
GH435-12	-6S	-7S	-16	-16	-22	-24	-25
GH435-16	-7S	-9S	-22	-22	-26	-28	-10
FC300-4	-12S	-2S	-8	-8	-11	-12	-21
FC300-5	-2S	-3S	-8	-8	-12	-15	-4
FC300-6	-14S	-4S	-10	-10	-13	-15	-5
FC300-8	-3S	-4S	-12		-16	-16	-6
FC300-10	-5S	-14S	-12	-12	-18	-18	-8
FC300-12	-6S	-7S	-16	-16	-20	-24	-27
FC300-16	-7S	-7S			-24	-24	-10
FC300-20	-9S	-8S	-22		-28	-32	-12
FC300-24	-8S	-10S		-30	-32	-32	-13
FC300-32		-11S			-40	-46	-30
FC300-40	-	-12S			-50		
FC350-4	-12S	-2S	-8	-8	-11	-12	-21
FC350-5	-2S	-3S	-8	-8	-12	-15	-4
FC350-6	-14S	-4S	-10	-10	-13	-15	-5
FC350-8	-3S	-5.1	-12		-16	-16	-6
FC350-10	-5S	-5.1	-12	-12	-18	-18	-8
FC350-12	-6S	-6S	-16	-16	-20	-24	-27
FC350-16	-7S	-7S			-24	-24	-10
FC350-20	-9S	-9S	-22		-28	-32	-12
FC350-24	-8S	-10S		-30	-32	-38	-13
FC355-4	-12S	-2S	-8	-8	-11	-12	-21
FC355-5	-2S	-3S	-8	-8	-12	-15	-4
FC355-6	-14S	-4S	-10	-10	-13	-15	-5
FC355-8	-3S	-4S	-12		-16	-16	-6
FC355-10	-5S	-14S	-12	-12	-18	-18	-8
FC355-12	-6S	-6S	-16	-16	-20	-24	-27
FC355-16	-7S	-7S			-24	-24	-10
FC355-20	-9S	-8S			-28	-32	-12
FC355-24	-8S	-10S		-30	-32	-32	-13
FC355-32		-11S			-40	-46	-30
FC234-5	-2S	-3S	-8	-8	-12	-15	-4

## Hose accessories

	900564	900705	GA7000555	GA7000696	624	FC425	900729
	Steel protective coil spring*	Steel protective coil sleeve*	Plastic protective coil sleeve*	Plastic protective coil spring*	Firesleeve*	Nylon abrasion sleeve*	Support clamp*
Hose part #							
FC234-6	-14S	-4S	-10	-10	-13	-15	-5
FC234-8	-3S	-4S			-16	-16	-6
FC234-10	-5S	-14S	-12	-12	-18	-20	-8
FC234-12	-6S	-6S	-16	-16	-20	-24	-27
FC234-16	-7S	-7S			-24	-24	-10
FC332-4							
FC332-6							
FC332-8							
FC332-10							
FC332-12							
GH100-4	-12S	-2S	-8	-8	-11	-12	-21
GH100-6	-2S	-3S	-10	-10	-12	-15	-4
GH100-8	-3S	-4S	-12		-16	-16	-6
GH100-10	-5S	-14S	-12	-12	-18	-20	-8
GH100-12	-6S	-6S	-16	-16	-20	-24	-27
GH101-4	-12S	-3S	-8	-8	-11	-12	-35
GH101-6	-14S	-4S	-10	-10	-13	-15	-5
GH101-8	-4S	-5.1	-12		-16	-16	-23
GH101-10	-5S	-14S	-12	-12	-18	-20	-8
FC619-12	-7S	-7S			-24	-24	-10
FC619-16	-9S	-9S	-22	-22	-28	-32	-12
FC619-20	-8S	-10S		-30	-32	-38	-13
FC619-24	-10S	-15S			-36	-38	-14
FC619-32	-11S				-46	-54	-15
FC619-40					-54	-59	
FC619-48							
WH004-12	-7S	-7S		-22	-26	-28	-10
WH004-16	-9S	-8S			-30	-32	-12
WH004-20	-10S	-10S			-36	-38	-14
WH004-24		-11S			-40	-46	-30
WH004-32	-11S				-48	-54	-16
WH004-40					-60		-17
WH004-48							
WH004-64							
EC190-12	-7S	-7S			-24	-24	-10
EC190-16	-9S	-9S	-22	-22	-28	-28	-11
EC190-20	-8S	-8S		-30	-32	-38	-13
EC190-24	-10S	-10S			-36	-38	-14
EC190-32	-11S				-46	-54	-15
EC190-40					-54	-59	
EC190-48							
GH507-20	-8S	-10S			-36	-38	-13
GH001-4	-1S	-13S	-6		-9	-12	-2
GH001-6	-2S	-3S	-8	-8	-12	-15	-4
GH001-8	-14S	-4S	-10	-10	-14	-15	-5
GH001-10	-3S	-5.1	-12		-16	-16	-6

	900564	900705	GA7000555	GA7000696	624	FC425	900729
	Steel protective coil spring*	Steel protective coil sleeve*	Plastic protective coil sleeve*	Plastic protective coil spring*	Firesleeve*	Nylon abrasion sleeve*	Support clamp*
							
Hose part #							
<b>GH001-12</b>	-5S	-14S		-12	-18	-20	-8
<b>GH001-16</b>	-6S	-7S	-16		-22	-24	-25
<b>FC800-12</b>	-6S	-6S	-16	-16	-20	-24	-27
<b>FC800-16</b>	-7S	-7S			-24	-24	-10
<b>FC800-20</b>	-9S	-9S			-28	-32	-12
<b>FC800-24</b>	-8S	-10S		-30	-32	-38	-13

## Hose accessories



Danfoss

# Machines and tooling

Manufactured by Uniflex





# Crimp machines

Reliable and high-quality machines enable accurate and efficient crimping—letting you achieve outstanding results more quickly, efficiently and safely.

Our portfolio includes one manual and four workshop crimpers, as well as two production crimping machines. While the manual and workshop machines meet small or mid-sized requirements, our production machines

can deliver the speed and efficiency demanded by large assembly lines. Our portfolio structure also reflects our global part numbers to make it easy to identify the right machines for your needs.

As well as offering crimpers with no crimp jaws, we also offer two types of kits for each machine that include the most commonly used dies.

**Presenting market-leading technology, our crimping machines offer many benefits—including:**

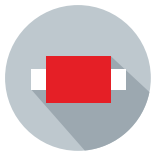

## Slide bearing technology

- No greasing improves machine cleanliness and prolongs lifetime
- Maximum productivity with very low maintenance cost
- Flanking cannot stick in grease; no risk of prematurely damaging the crimping head
- End product can be used in sanitary applications without cleaning
- 20% more capacity for crimping stronger or more difficult couplings versus competing crimpers
- Consistently accurate crimp results



## Large opening

(except ET4100 machine):

- Easy crimping of even 90° elbow pieces, without having to remove all the dies
- Compact design
- Fits in any workshop



## Ergonomic design

- Ease of use maximizes productivity



## Fixed 6-o'clock die

- Workpiece does not move, making it easier to position laterally
- Increases productivity, driving up profitability
- Reduces the risk of injuries

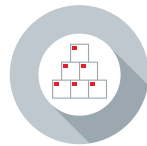

## Engineered solutions using quality components

- Hi-Low cylinder enables maximum efficiency while producing less heat
- Lateral reinforcement optimizes overall tolerance



## Low noise

- Very quiet hydraulic system improves operator experience



## CE compliant

## Ordering options

Our tooling portfolio has been specifically selected to meet the broadest spectrum of customer demand, based on:

- **The most used machines in the market**
- **The machines best aligned to our hose and fitting portfolio**
- **The machines needed to cover all key functions: crimping, cutting, insert pushing, skiving, etc**

### Our portfolio also features transparent coding:

ET4 - Workshop crimping machines

ET5 - Production crimping machines

ET6 - Nipple inserters, skiving machines, marking machines

ET7 - Crimp machine dies

ET9 - Cutting machines and blades



### Broad portfolio:

Our portfolio considers not only the best suited machines for our hoses and fittings, but also real-world use cases based on market intelligence about the most popular machines. This ensures we meet the broadest possible spectrum of customer needs.



### Easy to navigate portfolio:

We use easy to follow coding across our tooling portfolio so customers can quickly navigate between different types of machines.

**As well as offering crimping machines with no crimp jaws, we also offer two types of packages for each machine. These packages are designed to include the most commonly used dies:**



### Kit One

includes the crimping machine with an initial die package, which supports a good portion of our hose and fitting portfolio



### Kit Two

includes the crimping machine with more die sets than Kit1, allowing customers to crimp the broadest range of hoses

Kit One is the most economical option if customers don't need to crimp larger hose sizes, as it excludes a few of the bigger dies that are included in Kit Two.

Our portfolio structure reflects our global part numbers to make it easy to identify the right machines for a customer's needs.

## Crimp machine comparison chart

**ET4100**
**ET4200**
**ET4250**
**ET4300**
**ET4350**
**ET4400**

Description	Manual Crimper	Electric Crimper 1 Phase or 3 Phase	Mobile Electric Crimper with 12V	Electric Crimper 1 Phase or 3 Phase	Mobile Electric Crimper with 12V	Electric Crimper 1 Phase or 3 Phase
Production volume	Low	medium	medium	medium	medium	medium
Pump option**	manual	230V / 380 V	DC 12V - Mobile	230V / 380 V	DC 12V - Mobile	230V / 380 V
Application	Portable Crimper	Workshop Crimper	Portable Crimper	Workshop Crimper	Portable Crimper	Workshop Crimper
Capability Braided (up to)*	1 1/4" (Size -20)	1 1/2" (Size -24)	1 1/2" (Size -24)	2" (Size -32)	2" (Size -32)	2" (Size -32)
Capability 4-Spiral (up to)*	3/4" (Size -12)	1" (Size -16)	1" (Size -16)	1 1/4" (Size -20)	1 1/4" (Size -20)	2" (Size -32)
Capability 6-Spiral (up to)*	-	-	-	1 1/4" (Size -20)	1 1/4" (Size -20)	1 1/2" (Size -24)

\*Capabilities based on Danfoss core hose and fitting products

\*\*See pump ordering options for each machine for specific kit numbers

# Crimp machine comparison chart



Description	Electric Crimper 1 Phase or 3 Phase	Electric Crimper 3 Phase with Controller	Electric Crimper 3 Phase with Controller	Electric Crimper 3 Phase with Controller	Electric Crimper 3 Phase with Controller
<b>Production volume</b>	medium	medium	high	high	high
<b>Pump option**</b>	230V / 380 V	380 V	380 V	380 V	380 V
<b>Application</b>	Workshop Crimper	Workshop Crimper	Production Crimper	Production Crimper	Production Crimper
<b>Capability Braided (up to)*</b>	3" (Size -48)	3" (Size -48)	1 1/2" (Size -24)	2" (Size -32)	3" (Size -48)
<b>Capability 4-Spiral (up to)*</b>	2" (Size -32)	2" (Size -32)	1" (Size -16)	1 1/4" (Size -20)	3" (Size -48)
<b>Capability 6-Spiral (up to)*</b>	1 1/2" (Size -24)	1 1/2" (Size -24)	-	-	2 1/2" (Size -40)

\*Capabilities based on Danfoss core hose and fitting products

\*\*See pump ordering options for each machine for specific kit numbers

## Crimp machines

# ET4100

Mobile crimp machine

Field servicing

Customers with an aftersales business often need to change and crimp hoses in the field, outside of workshops. Portable, cost-effective, and easy to use, the ET4100 is the perfect choice for field servicing. It also features the biggest opening in the market—enabling it to support more hoses than most manual crimpers. No electrical connection is required, as the ET4100 functions with a hand pump. It offers a broad crimp capability that is sure to excite hose assemblers in the field.



- **Service hoses in the field:** Portable, cost-effective, and easy to use

### Tooling options

Danfoss Part Number	Description	Included crimp dies
ET4100-001	Crimp Machine ET4100	-
ET4100-001KT	Crimp Machine ET4100 Kit 1	ET7100-M150 ET7100-M170 ET7100-M190 ET7100-M230 ET7100-M260 ET7100-M280 ET7100-M290 ET7100-M320
ET4100-001K2	Crimp Machine ET4100 Kit2	ET7100-M150 ET7100-M170 ET7100-M190 ET7100-M230 ET7100-M260 ET7100-M280 ET7100-M290 ET7100-M320 ET7100-M360 ET7100-M400 ET7100-M440 ET7100-M460

**Note:** ET4100 manual crimp machine to be used with crimp dies ET7100-\*

### Specifications

**Dimensions:**

500mm x 420 mm x 440 mm

**Weight:** 32 kg

Crimp-force 900 kN

**Noise:** -

**Pump option:** manual

**Control unit:** micrometer

### Capabilities

**Braided hose:** -4 thru -20

**4-Spiral hose:** -6 thru -12

**6-Spiral hose:** -

### Features & Benefits

- Manual crimp machine with hand-pump
- Ideal for on-site servicing
- Can be mounted on service vehicles or bench tops
- Light weight makes it ideal for mobile applications

Visit the Danfoss PowerSource Crimp Specs tool at [www.Danfospowersource.com/crimp-specs/](http://www.Danfospowersource.com/crimp-specs/) to find the tooling needed for all of the hoses and fittings you plan to crimp

**ET4100 crimp die kits**

Die Set		ET7100-M*											
		150	170	190	230	260	280	290	320	360	400	440	460
ET4100	Kit 1	X	X	X	X	X	X	X	X				
	Kit 2	X	X	X	X	X	X	X	X	X	X	X	X
Aeroquip by Danfoss	GH681(B)	-4	-5	-6	-8	-10		-12		-16			-20
	GH781	-4	-5	-6	-8		-10		-12		-16		-20
	EC881(B)	-4	-5	-6	-8		-10	-12			-16		
	GH425(B)									-12			
	GH506									-12			
	FC500									-12			
	GH466												
	EC600									-12		-16	
	EC850							-10		-12			
	FC310	-4	-5	-6	-8	-10		-12			-16		-20
	FC510	-4		-6	-8	-10		-12			-16		-20
	GH195	-4		-6	-8		-10		-12		-16		-20
	EC525									-12		-16	-20
	GH120	-4		-6	-8		-10	-12			-16		-20
EC810									-12		-16		
Winner by Danfoss	EC115	-4	-5	-6	-8	-10		-12			-16		-20
	EC215	-4	-5	-6	-8		-10	-12					
	EC426					-6		-8	-10	-12			
	EC420									-12	-16		
	EC512									-12			
	EC615											-16	
	WH004							-12		-16	-20		
	WH006	-4	-5	-6	-8	-10		-12			-16		
WH007		-4	-5 / -6	-8			-10 / -12			-16			
Synflex by Danfoss	WHR7	-4 / -5	-6	-8		-10	-12			-16			
	WHR8		-4	-6 / -8			-12			-16			
	WHR18	-4	-5	-6	-8		-10						
	3TR7	-4	-5	-6 / -8		-10 / -12				-16			
	3TR8	-4		-6	-8		-12			-16			
	3TR18CT	-4 / -5	-6	-8		-10							
Danfoss	EC045	-4 / -5	-6	-8		-10		-12		-16 / -20			
	EC060		-4	-6	-8		-10	-12			-16	-20	
	EC112	-4	-5	-6	-8	-10		-12			-16		
	EC212	-4	-5	-6	-8		-10	-12			-16		-20
	EC190							-12		-16			-20
	FC699		-6	-8	-10			-12	-16				
	GH100		-6	-8	-10		-12						
Boston by Danfoss	EC116	-4 / -5		-6	-8								
	EC216	-4	-5	-6	-8								

## Crimp machines

# ET4200 and ET4250

General purpose crimp machine

Agriculture aftermarket

Companies supporting the agriculture segment need a reliable crimper for smaller hoses that balances quality and cost-effectiveness. Supporting smaller braided and spiral hoses, our reliable and versatile ET4200/ET4250 crimper is ideal for the agriculture aftermarket. The ET4200 / ET4250's compact construction allows for ergonomic working, while long master dies enable crimping of 90° elbow fittings up to 1¼".



- **Narrow and innovative user-friendly construction:** The ET4200 and ET4250's compact construction allows for ergonomic working.
- **High versatility:** Long master dies allow crimping of 90° elbow fittings up to 1¼".
- **Long service life:** The ET4200's tried and tested greaseless slide bearing technology reduces maintenance costs and increases product quality.
- **Service vehicle version:** use the ET4250 version with 12V pump as a mobile version or mounted on a desk bench

### Tooling options

Danfoss Part Number	Description	Voltage	Included crimp dies	
ET4200-001-230 (ET4250-001-012)	Crimp Machine ET4200 1PH (Crimp Machine ET4250-012)	230 V (12 V)	-	
ET4200-001-230KT (ET4250-001-012KT)	Crimp Machine ET4200 1PH Kit1 (Crimp Machine ET4250 Kit1)	230 V (12 V)	ET7200-M150 ET7200-M170 ET7200-M190 ET7200-M230 ET7200-M260	ET7200-M280 ET7200-M290 ET7200-M320 ET7200-M360
ET4200-001-230K2 (ET4250-001-012K2)	Crimp Machine ET4200 1PH Kit2 (Crimp Machine ET4250 Kit2)	230 V (12 V)	ET7200-M150 ET7200-M170 ET7200-M190 ET7200-M230 ET7200-M260 ET7200-M280	ET7200-M290 ET7200-M320 ET7200-M360 ET7200-M400 ET7200-M440 ET7200-M460
ET4200-001-380	Crimp Machine ET4200 3PH	380 V		
ET4200-001-380KT	Crimp Machine ET4200 3PH Kit1	380 V	ET7200-M150 ET7200-M170 ET7200-M190 ET7200-M230 ET7200-M260	ET7200-M280 ET7200-M290 ET7200-M320 ET7200-M360
ET4200-001-380K2	Crimp Machine ET4200 3PH Kit2	380 V	ET7200-M150 ET7200-M170 ET7200-M190 ET7200-M230 ET7200-M260 ET7200-M280	ET7200-M290 ET7200-M320 ET7200-M360 ET7200-M400 ET7200-M440 ET7200-M460

Note: ET4200 machine to be used with crimp dies ET7200-\*

### Specifications ET4200

**Dimensions:**

592mmx 545mmx 672mm

**Weight:** 150kg

**Crimp-force** 1200 kN

**Noise:** 69 dBA

**Pump option:** 230 V / 380 V

**Control unit:** micrometer

### Capabilities

**Braided hose:** -4 thru -24

**4-Spiral hose:** -6 thru -16

**6-Spiral hose:** -

### Specifications ET4250

**Dimensions:**

430mmx 370mmx 440mm

**Weight:** 110kg without engine

**Crimp-force** 1800 kN

**Noise:** 69 dBA

**Pump option:** 12V

**Control unit:** micrometer

### Capabilities

**Braided hose:** -4 thru -24

**4-Spiral hose:** -6 thru -16

**6-Spiral hose:** -

### Features & Benefits

- Semiautomatic machine for flexible use
- Accurate repeatability (ET4200)
- Mounted on a workbench
- Can be mounted on service vehicles or bench top (ET4250)

Visit the Danfoss PowerSource Crimp Specs tool at [www.Danfospowersource.com/crimp-specs/](http://www.Danfospowersource.com/crimp-specs/) to find the tooling needed for all of the hoses and fittings you plan to crimp

**ET4200 and ET4250 crimp die kits**

Die Set		ET7200-M*											
		150	170	190	230	260	280	290	320	360	400	440	460
<b>ET4200</b> <b>ET4250</b>	Kit 1	X	X	X	X	X	X	X	X	X			
	Kit 2	X	X	X	X	X	X	X	X	X	X	X	X
<b>Aeroquip by Danfoss</b>	GH681(B)	-4	-5	-6	-8	-10		-12		-16			-20
	GH781	-4	-5	-6	-8		-10		-12		-16		-20
	EC881(B)	-4	-5	-6	-8		-10	-12			-16		-20
	GH425(B)									-12		-16	
	GH506									-12		-16	
	FC500									-12		-16	
	GH466												
	EC600									-12		-16	
	EC850							-10		-12		-16	
	FC310	-4	-5	-6	-8	-10		-12			-16		-20
	FC510	-4		-6	-8	-10		-12			-16		-20
	GH195	-4		-6	-8		-10		-12		-16		-20
	EC525									-12		-16	-20
	GH120	-4		-6	-8		-10	-12			-16		-20
EC810									-12		-16		
<b>Winner by Danfoss</b>	EC115	-4	-5	-6	-8	-10		-12			-16		-20
	EC215	-4	-5	-6	-8		-10	-12			-16		-20
	EC426					-6		-8	-10	-12		-16	
	EC420									-12	-16		
	EC512									-12	-16		
	EC615											-16	
	WH004							-12		-16	-20		
	WH006	-4	-5	-6	-8	-10		-12			-16		
WH007		-4	-5 / -6	-8				-10 / -12			-16		
<b>Synflex by Danfoss</b>	WHR7	-4 / -5	-6	-8		-10	-12			-16			
	WHR8		-4	-6 / -8			-12				-16		
	WHR18	-4	-5	-6	-8		-10						
	3TR7	-4	-5	-6 / -8		-10 / -12				-16			
	3TR8	-4		-6	-8		-12			-16			
	3TR18CT	-4 / -5	-6	-8		-10							
<b>Danfoss</b>	EC045	-4 / -5	-6	-8		-10		-12		-16 / -20			
	EC060		-4	-6	-8		-10	-12			-16	-20	
	EC112	-4	-5	-6	-8	-10		-12			-16		
	EC212	-4	-5	-6	-8		-10	-12			-16		-20
	EC190							-12		-16			-20
	FC699		-6	-8	-10			-12	-16				
	GH100		-6	-8	-10		-12						
<b>Boston by Danfoss</b>	EC116	-4 / -5		-6	-8								
	EC216	-4	-5	-6	-8								



## Crimp machines

# ET4300 and ET4350

### General purpose crimp machine

#### Versatility and cost-effectiveness

Combining the benefits of a cost-effective small workshop machine with the versatility to manufacture a varied range of hose and fitting configurations thanks to solid master dies, the ET4300/ ET4350 crimpers are an unrivalled leader in the 1¼" field. While the ET4300 cannot crimp everything, it can meet the needs of most general assembly businesses.



- **High cost-effectiveness:** The ET4300/ET4350 sets the standard for quality and cost-effectiveness.
- **Narrow and innovative user-friendly construction:** The ET4300/ET4350's compact construction allows for ergonomic working.
- **High versatility:** Solid master dies allow crimping of all types of fittings.
- **Long service life:** The ET4300/ET4350's tried and tested greaseless slide bearing technology reduces maintenance costs and increases product quality.
- **Service vehicle version:** use the ET4350 version with 12V pump as a mobile version or mounted on a desk bench

#### Tooling options

Danfoss Part Number	Description	Voltage	Included crimp dies	
ET4300-001-230 (ET4350-001-012)	Crimp Machine ET4300 1PH (ET4350)	230 V (12 V)	-	
ET4300-001-230KT (ET4350-001-012KT)	Crimp Machine ET4300 1PH Kit1 (ET4350 Kit1)	230 V (12 V)	ET7200-M150 ET7200-M170 ET7200-M190 ET7200-M230 ET7200-M260	ET7200-M280 ET7200-M290 ET7200-M320 ET7200-M360 ET7200-M400
ET4300-001-230K2 (ET4350-001-012K2)	Crimp Machine ET4300 1PH Kit2 (ET4350 Kit 2)	230 V (12 V)	ET7200-M150 ET7200-M170 ET7200-M190 ET7200-M230 ET7200-M260 ET7200-M280 ET7200-M290	ET7200-M320 ET7200-M360 ET7200-M400 ET7200-M440 ET7200-M460 ET7200-M540
ET4300-001-380	Crimp Machine ET4300 3PH	380 V	-	
ET4300-001-380KT	Crimp Machine ET4300 3PH Kit1	380 V	ET7200-M150 ET7200-M170 ET7200-M190 ET7200-M230 ET7200-M260	ET7200-M280 ET7200-M290 ET7200-M320 ET7200-M360 ET7200-M400
ET4300-001-380K2	Crimp Machine ET4300 3PH Kit2	380 V	ET7200-M150 ET7200-M170 ET7200-M190 ET7200-M230 ET7200-M260 ET7200-M280 ET7200-M290	ET7200-M320 ET7200-M360 ET7200-M400 ET7200-M440 ET7200-M460 ET7200-M540

Note: ET4300 machine to be used with crimp dies ET7200\*

#### Specifications ET4300

##### Dimensions:

592mmx 545mmx 672mm

**Weight:** 160kg

**Crimp-force:** 1800 kN

**Noise:** 69 dBA

**Pump option:** 230 V / 380 V

**Control unit:** micrometer

#### Capabilities

**Braided hose:** -4 thru -32

**4-Spiral hose:** -6 thru -20

**6-Spiral hose:** -6 thru -20

#### Specifications ET4350

##### Dimensions:

509mmx 430mmx 485mm

**Weight:** 132kg

**Crimp-force:** 1800 kN

**Noise:** 69 dBA

**Pump option:** 12 V

**Control unit:** micrometer

#### Capabilities

**Braided hose:** -4 thru -32

**4-Spiral hose:** -6 thru -20

**6-Spiral hose:** -6 thru -20

#### Features & Benefits

- Semiautomatic machine for flexible use in shopfloor
- Accurate repeatability
- Energy efficient option for moderate volume assembly work – 30% usage per hour
- Can be mounted on service vehicles or bench top (ET4350)

Visit the Danfoss PowerSource Crimp Specs tool at [www.Danfosspowersource.com/crimp-specs/](http://www.Danfosspowersource.com/crimp-specs/) to find the tooling needed for all of the hoses and fittings you plan to crimp

## ET4300 and ET4350 crimp die kits

Die Set		ET7200-M*												
		150	170	190	230	260	280	290	320	360	400	440	460	540
<b>ET4300</b>	Kit 1	X	X	X	X	X	X	X	X	X	X			
	<b>ET4350</b>	Kit 2	X	X	X	X	X	X	X	X	X	X	X	X
<b>Aeroquip by Danfoss</b>	GH681(B)	-4	-5	-6	-8	-10		-12		-16			-20	-24
	GH781	-4	-5	-6	-8		-10		-12		-16		-20	-24
	EC881(B)	-4	-5	-6	-8		-10	-12			-16		-20	-24
	GH425(B)									-12		-16		
	GH506									-12		-16		
	FC500									-12		-16		-20
	GH466													-20
	EC600									-12		-16		-20
	EC850							-10		-12		-16		-20
	FC310	-4	-5	-6	-8	-10		-12			-16		-20	
	FC510	-4		-6	-8	-10		-12			-16		-20	
	GH195	-4		-6	-8		-10		-12		-16		-20	
	EC525									-12		-16		
	GH120	-4		-6	-8		-10	-12			-16		-20	-24
	EC810									-12		-16		-20
<b>Winner by Danfoss</b>	EC115	-4	-5	-6	-8	-10		-12			-16		-20	-24
	EC215	-4	-5	-6	-8		-10	-12			-16		-20	-24
	EC426					-6		-8	-10	-12		-16		
	EC420									-12	-16			-20
	EC512									-12	-16			
	EC615											-16		-20
	WH004							-12		-16	-20			-24
	WH006	-4	-5	-6	-8	-10		-12			-16			
WH007		-4	-5 / -6	-8			-10 / -12			-16				
<b>Synflex by Danfoss</b>	WHR7	-4 / -5	-6	-8		-10	-12			-16				
	WHR8		-4	-6 / -8			-12				-16			
	WHR18	-4	-5	-6	-8		-10							
	3TR7	-4	-5	-6 / -8		-10 / -12				-16				
	3TR8	-4		-6	-8		-12			-16				
	3TR18CT	-4 / -5	-6	-8		-10								
<b>Danfoss</b>	EC045	-4 / -5	-6	-8		-10		-12		-16 / -20				
	EC060		-4	-6	-8		-10	-12			-16	-20		
	EC112	-4	-5	-6	-8	-10		-12			-16			
	EC212	-4	-5	-6	-8		-10	-12			-16		-20	
	EC190							-12		-16			-20	
	FC699		-6	-8	-10			-12	-16					
	GH100		-6	-8	-10		-12							
<b>Boston by Danfoss</b>	EC116	-4 / -5		-6	-8									
	EC216	-4	-5	-6	-8									

## Crimp machines

# ET4400

### General purpose crimp machine

### Crimping large bore hose assemblies

Customers supporting the most demanding applications require machines that can crimp the biggest and heaviest hoses. Our ET4400 crimper offers the higher force and larger machine opening needed to crimp large bore hose assemblies. The ET4400 can crimp all hydraulic hose types, including R15 spiral hoses up to size -24, as well as industrial hose assemblies up to 3". Long master dies also allow crimping of 90° elbow fittings up to 2".



- **Narrow and innovative user-friendly construction:** The ET4400's compact construction allows for ergonomic working.
- **Large crimping tool:** Enables crimping of industrial hose assemblies up to 3".
- **High versatility:** Long master dies allows crimping of 90° elbow fittings up to 2".
- **Long service life:** The ET4400's tried and tested greaseless slide bearing technology reduces maintenance costs and increases product quality.

### Tooling options

Danfoss Part Number	Description	Voltage	Included crimp dies	
ET4400-001-230	Crimp Machine ET4400 1PH	230 V	-	
ET4400-001-230KT	Crimp Machine ET4400 1PH Kit1	230 V	ET7200-M150 ET7200-M170 ET7200-M190 ET7200-M230 ET7200-M260 ET7200-M280	ET7200-M290 ET7200-M320 ET7200-M360 ET7200-M400 ET7200-M440
ET4400-001-230K2	Crimp Machine ET4400 1PH Kit2	230 V	ET7200-M150 ET7200-M170 ET7200-M190 ET7200-M230 ET7200-M260 ET7200-M280 ET7200-M290	ET7200-M320 ET7200-M360 ET7200-M400 ET7200-M440 ET7200-M460 ET7200-M540 ET7400-M620
ET4400-001-380	Crimp Machine ET4400 3PH	380 V	-	
ET4400-001-380KT	Crimp Machine ET4400 3PH Kit1	380 V	ET7200-M150 ET7200-M170 ET7200-M190 ET7200-M230 ET7200-M260 ET7200-M280	ET7200-M290 ET7200-M320 ET7200-M360 ET7200-M400 ET7200-M440
ET4400-001-380K2	Crimp Machine ET4400 3PH Kit2	380 V	ET7200-M150 ET7200-M170 ET7200-M190 ET7200-M230 ET7200-M260 ET7200-M280 ET7200-M290	ET7200-M320 ET7200-M360 ET7200-M400 ET7200-M440 ET7200-M460 ET7200-M540 ET7400-M620

**Note:** ET4400 machine to be used with crimp intermediate die ET7400-7200 in combination with ET7200. ET4400 machine to be used with crimp dies ET7400.

### Specifications

#### Dimensions:

700mmx 600mmx 735mm

**Weight:** 248 kg

**Crimp-force** 2000 kN

**Noise:** 69 dBA

**Pump option:** 230 V / 380 V

**Control Unit:** micrometer

### Capabilities

**Braided hose:** -4 thru -32

**4-Spiral hose:** -6 thru -32

**6-Spiral hose:** -6 thru -24

### Features & Benefits

- The perfect workshop crimper for bigger and spiral hoses also.
- Can be mounted on bench top
- Accurate repeatability

Visit the Danfoss PowerSource Crimp Specs tool at [www.Danfosspowersource.com/crimp-specs/](http://www.Danfosspowersource.com/crimp-specs/) to find the tooling needed for all of the hoses and fittings you plan to crimp

## ET4400 crimp die kits

Die Set		ET7200-M*													ET7400-M*
		150	170	190	230	260	280	290	320	360	400	440	460	540	620
ET4400	Kit 1	X	X	X	X	X	X	X	X	X	X	X			
	Kit 2	X	X	X	X	X	X	X	X	X	X	X	X	X	X
Aeroquip by Danfoss	GH681(B)	-4	-5	-6	-8	-10		-12		-16			-20	-24	
	GH781	-4	-5	-6	-8		-10		-12		-16		-20	-24	
	EC881(B)	-4	-5	-6	-8		-10	-12			-16		-20	-24	
	GH425(B)									-12		-16			
	GH506									-12		-16			
	FC500									-12		-16		-20	
	GH466													-20	-24
	EC600									-12		-16		-20	-24
	EC850							-10		-12		-16		-20	
	FC310	-4	-5	-6	-8	-10		-12			-16		-20		
	FC510	-4		-6	-8	-10		-12			-16		-20		
	GH195	-4		-6	-8		-10		-12		-16		-20		
	EC525									-12		-16			
	GH120	-4		-6	-8		-10	-12			-16		-20	-24	
EC810									-12		-16		-20	-24	
Winner by Danfoss	EC115	-4	-5	-6	-8	-10		-12			-16		-20	-24	
	EC215	-4	-5	-6	-8		-10	-12			-16		-20	-24	
	EC426					-6		-8	-10	-12		-16			
	EC420									-12	-16			-20	-24
	EC512									-12	-16				
	EC615											-16		-20	-24
	WH004							-12		-16	-20			-24	
	WH006	-4	-5	-6	-8	-10		-12			-16				
WH007		-4	-5 / -6	-8			-10 / -12			-16					
Synflex by Danfoss	WHR7	-4 / -5	-6	-8		-10	-12			-16					
	WHR8		-4	-6 / -8			-12			-16					
	WHR18	-4	-5	-6	-8		-10								
	3TR7	-4	-5	-6 / -8		-10 / -12				-16					
	3TR8	-4		-6	-8		-12			-16					
	3TR18CT	-4 / -5	-6	-8		-10									
Danfoss	EC045	-4 / -5	-6	-8		-10		-12		-16 / -20					
	EC060		-4	-6	-8		-10	-12			-16	-20			
	EC112	-4	-5	-6	-8	-10		-12			-16				
	EC212	-4	-5	-6	-8		-10	-12			-16		-20		
	EC190							-12		-16			-20		
	FC699		-6	-8	-10			-12	-16						
	GH100		-6	-8	-10			-12							
Boston by Danfoss	EC116	-4 / -5		-6	-8										
	EC216	-4	-5	-6	-8										

## Crimp machines

# ET4500 and ET4500-002

### General purpose crimp machine Crimping large bore hose assemblies

Customers supporting the most demanding applications require machines that can crimp the biggest and heaviest hoses. With a wider opening and a stronger crimping force than other workshop machines, the ET4500 offers a capacity that's almost at the level of production machines, but at a much lower cost. The ET4500 is designed to crimp hydraulic hose assemblies up to 2", including R15 spiral hoses up to size -32, and industrial hose assemblies up to 3". -002 version available with an optional controller, while ET4500 -001 version is working with micrometer.



- **Cost-effective capacity:** The ET4500 boasts a large capacity, almost at the level of production machines, but at a much lower cost.
- **Large crimping tool:** Enables crimping of industrial hose assemblies up to 3".
- **High versatility:** Crimps all hydraulic hoses, including R15 spiral hoses up to size -32, as well as industrial hose assemblies up to 3".
- **Optional controller ( code -002):** Preset with Danfoss crimp specifications, our controller enables easier and faster crimping

### Tooling options

Danfoss Part Number	Description	Voltage	Included crimp dies	
ET4500-001-230 (ET4500-002-230)	Crimp Machine ET4500 1PH	230 V	-	
ET4500-001-230KT (ET4500-002-230KT)	Crimp Machine ET4500 1PH Kit1	230 V	ET7200-M150 ET7200-M170 ET7200-M190 ET7200-M230 ET7200-M260 ET7200-M280	ET7200-M290 ET7200-M320 ET7200-M360 ET7200-M400 ET7200-M440
ET4500-001-230K2 (ET4500-002-230K2)	Crimp Machine ET4500 1PH Kit2	230 V	ET7200-M150 ET7200-M170 ET7200-M190 ET7200-M230 ET7200-M260 ET7200-M280 ET7200-M290	ET7200-M320 ET7200-M360 ET7200-M400 ET7200-M440 ET7200-M460 ET7200-M540 ET7400-M620
ET4500-001-380	Crimp Machine ET4500 3PH	380 V	-	
ET4500-001-380KT (ET4500-002-380KT)	Crimp Machine ET4500 3PH Kit1	380 V	ET7200-M150 ET7200-M170 ET7200-M190 ET7200-M230 ET7200-M260 ET7200-M280	ET7200-M290 ET7200-M320 ET7200-M360 ET7200-M400 ET7200-M440
ET4500-001-380K2 (ET4500-002-380K2)	Crimp Machine ET4500 3PH Kit2	380 V	ET7200-M150 ET7200-M170 ET7200-M190 ET7200-M230 ET7200-M260 ET7200-M280 ET7200-M290	ET7200-M320 ET7200-M360 ET7200-M400 ET7200-M440 ET7200-M460 ET7200-M540 ET7400-M620

**Note:** ET4500 machine to be used with crimp intermediate die ET7400-7200 in combination with ET7200.  
ET4500 machine to be used with crimp dies ET7400.

### Specifications

#### Dimensions:

745mmx 600mmx 1350mm

**Weight:** 450 kg

**Crimp-force** 2800 kN

**Noise:** 69 dBA

**Pump option:** 230 V / 380 V

**Control unit:** micrometer/  
Controller

### Capabilities

**Braided hose:** -4 thru -48

**4-Spiral hose:** -6 thru -32

**6-Spiral hose:** -6 thru -24

### Features & Benefits

- Our top capacity workshop machine enables assembly of big sizes and spiral hoses
- Optional controller with Danfoss crimp specifications, our controller enables easier and faster crimping (ET4500-002)

Visit the Danfoss PowerSource Crimp Specs tool at [www.Danfosspowersource.com/crimp-specs/](http://www.Danfosspowersource.com/crimp-specs/) to find the tooling needed for all of the hoses and fittings you plan to crimp

**ET4500 and ET4500-002 crimp die kits**

Die Set		ET7200-M*													ET7400-M*	
		150	170	190	230	260	280	290	320	360	400	440	460	540	620	
<b>ET4500</b> <b>ET4500-002</b>	Kit 1	X	X	X	X	X	X	X	X	X	X	X				
	Kit 2	X	X	X	X	X	X	X	X	X	X	X	X	X	X	
<b>Aeroquip by Danfoss</b>	GH681(B)	-4	-5	-6	-8	-10		-12		-16			-20	-24		
	GH781	-4	-5	-6	-8			-10		-12		-16		-20	-24	
	EC881(B)	-4	-5	-6	-8			-10	-12			-16		-20	-24	
	GH425(B)										-12		-16			
	GH506										-12		-16			
	FC500										-12		-16		-20	
	GH466														-20	-24
	EC600										-12		-16		-20	-24
	EC850								-10		-12		-16		-20	
	FC310	-4	-5	-6	-8	-10			-12			-16		-20		
	FC510	-4		-6	-8	-10			-12			-16		-20		
	GH195	-4		-6	-8			-10		-12		-16		-20		
	EC525										-12		-16			
	GH120	-4		-6	-8			-10	-12			-16		-20	-24	
EC810										-12		-16		-20	-24	
<b>Winner by Danfoss</b>	EC115	-4	-5	-6	-8	-10		-12			-16		-20	-24		
	EC215	-4	-5	-6	-8		-10	-12			-16		-20	-24		
	EC426					-6		-8	-10	-12		-16				
	EC420									-12	-16			-20	-24	
	EC512									-12	-16					
	EC615											-16		-20	-24	
	WH004								-12		-16	-20			-24	
	WH006	-4	-5	-6	-8	-10			-12			-16				
WH007		-4	-5 / -6	-8				-10 / -12			-16					
<b>Synflex by Danfoss</b>	WHR7	-4 / -5	-6	-8		-10	-12				-16					
	WHR8		-4	-6 / -8			-12				-16					
	WHR18	-4	-5	-6	-8		-10									
	3TR7	-4	-5	-6 / -8		-10 / -12					-16					
	3TR8	-4		-6	-8		-12				-16					
	3TR18CT	-4 / -5	-6	-8		-10										
<b>Danfoss</b>	EC045	-4 / -5	-6	-8		-10	-12			-16 / -20						
	EC060		-4	-6	-8		-10	-12			-16	-20				
	EC112	-4	-5	-6	-8	-10		-12			-16					
	EC212	-4	-5	-6	-8		-10	-12			-16		-20			
	EC190							-12			-16			-20		-32
	FC699		-6	-8	-10			-12	-16							
	GH100		-6	-8	-10			-12								
<b>Boston by Danfoss</b>	EC116	-4 / -5		-6	-8											
	EC216	-4	-5	-6	-8											

## Crimp machines

# ET5020

### Industrial production crimp machines

#### On-site production

ET5020/ET5025 enables high productivity, safety, and ease-of-use. Compact, user-friendly construction enables high productivity, safety and ease-of-use, while solid master dies allow crimping of all fitting types. Available with an optional controller.

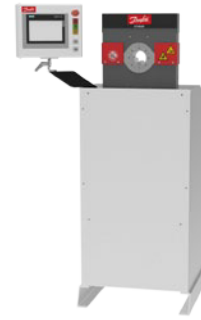

- **Narrow and innovative user-friendly construction:** The ET5020's compact construction allows for ergonomic working. High versatility: Solid master dies allow crimping of all types of fittings.
- **Long service life:** The ET5020's tried and tested greaseless slide bearing technology reduces maintenance costs and increases product quality.
- **With a controller :** PresETwith Danfoss crimp specifications, our controller enables easier and faster crimping
- **For bigger hoses:** Choose ET5025 for sizes up to braided 32, and spiral 24

#### Tooling options

Danfoss Part Number	Description	Voltage	Included crimp dies
ET5020-001-380	Crimp Machine ET5020 3PH	380 V	-
ET5020-001-380KT	Crimp Machine ET5020 3PH Kit1	380 V	ET7300-M150 ET7300-M170 ET7300-M190 ET7300-M230 ET7300-M260 ET7300-M280 ET7300-M290 ET7300-M320 ET7300-M360 ET7300-M400
ET5020-001-380K2	Crimp Machine ET5020 3PH Kit2	380 V	ET7300-M150 ET7300-M170 ET7300-M190 ET7300-M230 ET7300-M260 ET7300-M280 ET7300-M290 ET7300-M320 ET7300-M360 ET7300-M400 ET7300-M440 ET7300-M460

Note: ET5020 machine to be used with crimp dies ET7300.

#### Specifications

##### Dimensions:

625mmx 560mmx 1450mm

##### Weight:

310 kg

##### Crimp-force:

1350 kN

##### Noise:

53 dBA

##### Pump option:

380 V

##### Control unit:

Controller

#### Capabilities

Braided hose: -4 thru -24

4-Spiral hose: -6 thru -16

6-Spiral hose: -

#### Features & Benefits

- Production machine with Hi-Lo cylinder –high performance and low build up of heat
- Adjustable crimp diameter by digital touch control panel (complete Danfoss hose designs with crimp diameter)

Visit the Danfoss PowerSource Crimp Specs tool at [www.Danfospowersource.com/crimp-specs/](http://www.Danfospowersource.com/crimp-specs/) to find the tooling needed for all of the hoses and fittings you plan to crimp

**ET5020 crimp die kits**

Die Set		ET7300-M*											
		150	170	190	230	260	280	290	320	360	400	440	460
ET5020	Kit 1	X	X	X	X	X	X	X	X	X	X		
	Kit 2	X	X	X	X	X	X	X	X	X	X	X	X
Aeroquip by Danfoss	GH681(B)	-4	-5	-6	-8	-10		-12		-16			-20
	GH781	-4	-5	-6	-8		-10		-12		-16		-20
	EC881(B)	-4	-5	-6	-8		-10	-12			-16		-20
	GH425(B)									-12		-16	
	GH506									-12		-16	
	FC500									-12		-16	
	GH466												
	EC600												
	EC850							-10		-12		-16	
	FC310	-4	-5	-6	-8	-10		-12			-16		-20
	FC510	-4		-6	-8	-10		-12			-16		-20
	GH195	-4		-6	-8		-10		-12		-16		-20
	EC525									-12		-16	
	GH120	-4		-6	-8		-10	-12			-16		-20
EC810									-12		-16		
Winner by Danfoss	EC115	-4	-5	-6	-8	-10		-12			-16		-20
	EC215	-4	-5	-6	-8		-10	-12			-16		-20
	EC426					-6		-8	-10	-12		-16	
	EC420									-12	-16		
	EC512									-12	-16		
	EC615											-16	
	WH004							-12		-16	-20		
	WH006	-4	-5	-6	-8	-10		-12			-16		
WH007		-4	-5 / -6	-8			-10 / -12			-16			
Synflex by Danfoss	WHR7	-4 / -5	-6	-8		-10	-12			-16			
	WHR8		-4	-6 / -8			-12				-16		
	WHR18	-4	-5	-6	-8		-10						
	3TR7	-4	-5	-6 / -8		-10 / -12				-16			
	3TR8	-4		-6	-8		-12			-16			
	3TR18CT	-4 / -5	-6	-8		-10							
Danfoss	EC045	-4 / -5	-6	-8		-10		-12		-16 / -20			
	EC060		-4	-6	-8		-10	-12			-16	-20	
	EC112	-4	-5	-6	-8	-10		-12			-16		
	EC212	-4	-5	-6	-8		-10	-12			-16		-20
	EC190							-12		-16			-20
	FC699		-6	-8	-10			-12	-16				
	GH100		-6	-8	-10		-12						
Boston by Danfoss	EC116	-4 / -5		-6	-8								
	EC216	-4	-5	-6	-8								



## Crimp machines

# ET5025

### Industrial production crimp machines

#### On-site production

ET5020/ET5025 enables high productivity, safety, and ease-of-use. Compact, user-friendly construction enables high productivity, safety and ease-of-use, while solid master dies allow crimping of all fitting types. Available with an optional controller.



- **Narrow and innovative user-friendly construction:** The ET5025's compact construction allows for ergonomic working. High versatility: Solid master dies allow crimping of all types of fittings.
- **Long service life:** The ET5025's tried and tested greaseless slide bearing technology reduces maintenance costs and increases product quality.
- **With a controller :** Preset with Danfoss crimp specifications, our controller enables easier and faster crimping

#### Tooling options

Danfoss Part Number	Description	Voltage	Included crimp dies
ET5025-001-380	Crimp Machine ET5025 3PH	380 V	-
ET5025-001-380KT	Crimp Machine ET5025 3PH Kit1	380 V	ET7300-M150 ET7300-M170 ET7300-M190 ET7300-M230 ET7300-M260 ET7300-M280 ET7300-M290 ET7300-M320 ET7300-M360 ET7300-M400
ET5025-001-380K2	Crimp Machine ET5025 3PH Kit2	380 V	ET7300-M150 ET7300-M170 ET7300-M190 ET7300-M230 ET7300-M260 ET7300-M280 ET7300-M290 ET7300-M320 ET7300-M360 ET7300-M400 ET7300-M440 ET7300-M460

Note: ET5020 machine to be used with crimp dies ET7300.

#### Specifications

##### Dimensions:

645mmx 560mmx 1470mm

##### Weight:

470 kg

Crimp-force 1600 kN

##### Noise:

53 dBA

##### Pump option:

380 V

##### Control unit:

Controller

#### Capabilities

**Braided hose:** -4 thru -32

**4-Spiral hose:** -6 thru -20

**6-Spiral hose:** -

#### Features & Benefits

- Production machine with Hi-Lo cylinder –high performance and low build up of heat

- Adjustable crimp diameter by digital touch control panel (complete Danfoss hose designs with crimp diameter)

- Choose ET5025 for bigger sizes and higher force

Visit the Danfoss PowerSource Crimp Specs tool at [www.Danfosspowersource.com/crimp-specs/](http://www.Danfosspowersource.com/crimp-specs/) to find the tooling needed for all of the hoses and fittings you plan to crimp

**ET5025 crimp die kits**

Die Set		ET7300-M*											
		150	170	190	230	260	280	290	320	360	400	440	460
<b>ET5025</b>	Kit 1	X	X	X	X	X	X	X	X	X	X		
	Kit 2	X	X	X	X	X	X	X	X	X	X	X	X
<b>Aeroquip by Danfoss</b>	GH681(B)	-4	-5	-6	-8	-10		-12		-16			-20
	GH781	-4	-5	-6	-8		-10		-12		-16		-20
	EC881(B)	-4	-5	-6	-8		-10	-12			-16		-20
	GH425(B)									-12		-16	
	GH506									-12		-16	
	FC500									-12		-16	
	GH466												
	EC600												
	EC850							-10		-12		-16	
	FC310	-4	-5	-6	-8	-10		-12			-16		-20
	FC510	-4		-6	-8	-10		-12			-16		-20
	GH195	-4		-6	-8		-10		-12		-16		-20
	EC525									-12		-16	
	GH120	-4		-6	-8		-10	-12			-16		-20
	EC810									-12		-16	
<b>Winner by Danfoss</b>	EC115	-4	-5	-6	-8	-10		-12			-16		-20
	EC215	-4	-5	-6	-8		-10	-12			-16		-20
	EC426					-6		-8	-10	-12		-16	
	EC420									-12	-16		
	EC512									-12	-16		
	EC615											-16	
	WH004							-12		-16	-20		
	WH006	-4	-5	-6	-8	-10		-12			-16		
WH007		-4	-5 / -6	-8			-10 / -12			-16			
<b>Synflex by Danfoss</b>	WHR7	-4 / -5	-6	-8		-10	-12			-16			
	WHR8		-4	-6 / -8			-12				-16		
	WHR18	-4	-5	-6	-8		-10						
	3TR7	-4	-5	-6 / -8		-10 / -12				-16			
	3TR8	-4		-6	-8		-12			-16			
	3TR18CT	-4 / -5	-6	-8		-10							
<b>Danfoss</b>	EC045	-4 / -5	-6	-8		-10		-12		-16 / -20			
	EC060		-4	-6	-8		-10	-12			-16	-20	
	EC112	-4	-5	-6	-8	-10		-12			-16		
	EC212	-4	-5	-6	-8		-10	-12			-16		-20
	EC190							-12		-16			-20
	FC699		-6	-8	-10			-12	-16				
	GH100		-6	-8	-10		-12						
<b>Boston by Danfoss</b>	EC116	-4 / -5		-6	-8								
	EC216	-4	-5	-6	-8								

## Crimp machines

# ET5070

### Industrial production crimp machines High volume on-site production

On-site facilities with the highest production rates need a high-end crimper that offers reliability, safety, ease-of-use, and excellent productivity. The ET5070 is a powerful and fast programmable crimper, ideal for on-site serial production. Designed for operator safety, improved ergonomics, increased hose size capability, ease of use, and maximum productivity, the ET5070 can meet almost any challenge across a broad range of hose sizes and construction types. Available with an optional controller.

- **High versatility:** Unlike other production machines which offer limited openings or crimping power, the ET5070 can meet almost any challenge across a broad range of hose sizes and construction types.
- **Fast and safe operations:** The ET5070 is designed for ease-of-use and operator safety, enabling faster cycle times and higher productivity.
- **Quickly setup multiple crimps:** The ET5070 increases throughput by reducing the time needed to set-up multiple crimps.
- **Grease-free dies:** Dies can be changed more easily and cleanly, reducing the chance of operator error, since there's no need to apply grease to dies and the crimp ring.
- **Smart assembly support:** The ET5070 comes pre-programmed with Danfoss hose and fitting specifications to enable easier and faster crimping, with fewer errors and less waste. In addition, the ET5070 assists the user in selecting approved Danfoss hose fittings for each hose part number, as well as the dies required for each assembly—enabling the creation of OEM-quality hose assemblies.
- **With a controller:** Preset with Danfoss crimp specifications, our controller enables easier and faster crimping

### Tooling options

Danfoss Part Number	Description	Voltage	Included crimp dies
ET5070-001-380	Crimp Machine ET5070 1PH	380 V	-
ET5070-001-380KT	Crimp Machine ET5070 1PH Kit1	380 V	ET7200-M150 ET7200-M170 ET7200-M190 ET7200-M230 ET7200-M260 ET7200-M280 ET7200-M290 ET7200-M320 ET7200-M360 ET7200-M400 ET7200-M440
ET5070-001-380K2	Crimp Machine ET5070 1PH Kit2	380 V	ET7200-M150 ET7200-M170 ET7200-M190 ET7200-M230 ET7200-M260 ET7200-M280 ET7200-M290 ET7200-M320 ET7200-M360 ET7200-M400 ET7200-M440 ET7200-M460 ET7200-M540 ET7500-M620



### Specifications

- Dimensions:**  
1200mmx 600mmx 1700mm
- Weight:** 750 kg  
Crimp-force 3150 kN
- Noise:** 62 dBA  
pump option: 380 V
- Control unit:** Controller

### Capabilities

- Braided hose:** -4 thru -48  
**4-Spiral hose:** -6 thru -48  
**6-Spiral hose:** -6 thru -40

### Features & Benefits

- Production machine with HiLo cylinder –high performance and low warm building
- Adjustable crimp diameter by digital touch control panel (complete Danfoss hose designs with crimp diameter)
- High volume production machine

Visit the Danfoss PowerSource Crimp Specs tool at [www.Danfospowersource.com/crimp-specs/](http://www.Danfospowersource.com/crimp-specs/) to find the tooling needed for all of the hoses and fittings you plan to crimp

**Note:** ET5070 machine to be used with intermediate die ET7500-7200 in combination with ET7200.

ET5070 machine to be used with crimp dies ET7500.

**ET5070 crimp die kits**

Die Set		ET7200-M*													ET7500-M*	
		150	170	190	230	260	280	290	320	360	400	440	460	540	620	
<b>ET5070</b>	Kit 1	X	X	X	X	X	X	X	X	X	X	X				
	Kit 2	X	X	X	X	X	X	X	X	X	X	X	X	X	X	
<b>Aeroquip by Danfoss</b>	GH681(B)	-4	-5	-6	-8	-10		-12		-16			-20	-24		
	GH781	-4	-5	-6	-8			-10		-12		-16		-20	-24	
	EC881(B)	-4	-5	-6	-8			-10	-12			-16		-20	-24	
	GH425(B)										-12		-16			
	GH506										-12		-16			
	FC500										-12		-16		-20	
	GH466													-20	-24	
	EC600										-12		-16		-20	-24
	EC850								-10		-12		-16		-20	
	FC310	-4	-5	-6	-8	-10			-12			-16		-20		
	FC510	-4		-6	-8	-10			-12			-16		-20		
	GH195	-4		-6	-8			-10		-12		-16		-20		
	EC525										-12		-16			
	GH120	-4		-6	-8			-10	-12			-16		-20	-24	
EC810										-12		-16		-20	-24	
<b>Winner by Danfoss</b>	EC115	-4	-5	-6	-8	-10		-12			-16		-20	-24		
	EC215	-4	-5	-6	-8			-10	-12		-16		-20	-24		
	EC426					-6		-8	-10	-12		-16				
	EC420									-12	-16			-20	-24	
	EC512									-12	-16					
	EC615											-16		-20	-24	
	WH004								-12		-16	-20			-24	
	WH006	-4	-5	-6	-8	-10			-12			-16				
WH007		-4	-5 / -6	-8				-10 / -12			-16					
<b>Synflex by Danfoss</b>	WHR7	-4 / -5	-6	-8		-10	-12				-16					
	WHR8		-4	-6 / -8			-12				-16					
	WHR18	-4	-5	-6	-8			-10								
	3TR7	-4	-5	-6 / -8		-10 / -12					-16					
	3TR8	-4		-6	-8			-12			-16					
	3TR18CT	-4 / -5	-6	-8		-10										
<b>Danfoss</b>	EC045	-4 / -5	-6	-8		-10	-12			-16 / -20						
	EC060		-4	-6	-8		-10	-12			-16	-20				
	EC112	-4	-5	-6	-8	-10		-12			-16					
	EC212	-4	-5	-6	-8			-10	-12			-16		-20		
	EC190								-12		-16			-20		-32
	FC699		-6	-8	-10				-12	-16						
	GH100		-6	-8	-10			-12								
<b>Boston by Danfoss</b>	EC116	-4 / -5		-6	-8											
	EC216	-4	-5	-6	-8											

# Crimp die recommendation

For the most common Danfoss hoses

Hose / Size		-3	-4	-5	-6	-8	-10	-12	-16	-20	-24	-32
Aeroquip by Danfoss	GH681(B)		M150	M170	M190	M230	M260	M290	M360	M460	M540	M670
	GH781		M150	M170	M190	M230	M280	M290	M400	M460	M540	M670
	EC881(B)		M150	M170	M190	M230	M280	M290	M400	M460	M540	M670
	GH425(B)				M260	M280	M320	M360	M400			
	GH506							M360	M440	M500	M570	M710
	FC500							M360	M440	M500	M570	M780
	GH466									M540	M620	M780
	EC600							M360	M440	M540	M620	M780
	EC850						M290	M360	M440	M570		
	FC310	M120	M150	M170	M190	M230	M260	M290	M400	M460		
	FC510		M150		M190	M230	M260	M290	M400	M460		
	GH195		M150		M190	M230	M280	M320	M400	M500	M570	M670
	EC525							M360	M440	M530	M570	M710
	GH120		M150		M190	M230	M280	M290	M400	M460	M540	M670
	EC810				M260	M280	M320	M360	M440	M540	M620	M780
Winner by Danfoss	EC115		M170	M170	M190	M230	M260	M290	M360	M440	M540	M620
	EC215		M170	M190	M190	M230	M280	M290	M360	M460	M540	M670
	EC426				M260	M280	M320	M360	M440	M530		
	EC420							M360	M440	M570	M620	M780
	EC512							M360	M440	M530	M570	M710
	EC615							M360	M440	M530	M570	M710
	WH004							M290	M360	M400	M540	M670
	WH006	M120	M150	M170	M190	M230	M260	M290	M400			
WH007		M170	M190	M190	M230	M290	M290	M400				
Synflex by Danfoss	WHR7	M090/M120	M150	M150	M170	M190	M240	M280	M360			
	WHR8		M170		M190	M190		M280	M400			
	WHR18	M120	M150	M170	M190	M230	M280					
	3TR7		M150	M150	M170	M190	M230	M260	M360			
	3TR8		M150		M190	M230		M280	M360			
	3TR18CT		M150	M150	M170	M200	M260					
Danfoss	EC007				F0106	F0108	F0110	F0112				
	GH001		F0104		F0106	F0108	F0110	F0112	F0116			
	EC045	M120	M120	M150	M170	M190	M230	M290	M360			
	EC060		M170		M190	M230	M280	M290	M400	M440		
	EC112		M150	M170	M190	M230	M260	M290	M400			
	EC212		M150	M170	M190	M230	M280	M290	M400	M460	M530	M670
	EC190							M290	M360	M460	M530	M620
	FC699		M120		M170	M190	M230	M290	M320			
GH100		M120		M170	M190	M230	M290					
Boston by Danfoss	EC116		M150	M150	M190	M230						
	EC216		M150	M170	M190	M230						

## Crimp dies per diameter

diameter	Part Number
Ø6,8	ET7100-M068
Ø9,0	ET7100-M090
Ø12,0	ET7100-M120
Ø14,0	ET7100-M140
Ø15,0	ET7100-M150
Ø17,0	ET7100-M170
Ø19,0	ET7100-M190
Ø20,0	ET7100-M200
Ø23,0	ET7100-M230
Ø24,0	ET7100-M240
Ø26,0	ET7100-M260
Ø28,0	ET7100-M280
Ø29,0	ET7100-M290
Ø32,0	ET7100-M320
Ø36,0	ET7100-M360
Ø40,0	ET7100-M400
Ø44,0	ET7100-M440
Ø46,0	ET7100-M460
Ø47,0	ET7100-M470
diameter	Part Number
Ø54,0	ET7500-M540
Ø57,0	ET7500-M570
Ø62,0	ET7500-M620
Ø67,0	ET7500-M670
Ø71,0	ET7500-M710
Ø74,0	ET7500-M740
Ø78,0	ET7500-M780
Ø84,0	ET7500-M840
Ø86,0	ET7500-M860
Ø90,0	ET7500-M900
Ø92,0	ET7400-M920
Ø96,0	ET7500-M960
Ø103,0	ET7500-M1030
Ø106,0	ET7500-M1060
Ø111,0	ET7500-M1110
Ø116,0	ET7500-M1160
Ø121,0	ET7500-M1210
Ø126,0	ET7500-M1260
Ø131,0	ET7500-M1310

diameter	Part Number
Ø6,8	ET7200-M068
Ø9,0	ET7200-M090
Ø12,0	ET7200-M100
Ø14,0	ET7200-M120
Ø15,0	ET7200-M140
Ø17,0	ET7200-M150
Ø16,0	ET7200-M160
Ø17,0	ET7200-M170
Ø19,0	ET7200-M190
Ø20,0	ET7200-M200
Ø22,0	ET7200-M220
Ø23,0	ET7200-M230
Ø24,0	ET7200-M240
Ø26,0	ET7200-M260
Ø28,0	ET7200-M280
Ø29,0	ET7200-M290
Ø30,0	ET7200-M300
Ø31,0	ET7200-M310
Ø32,0	ET7200-M320
Ø34,0	ET7200-M340
Ø36,0	ET7200-M360
Ø38,0	ET7200-M380
Ø39,0	ET7200-M390
Ø40,0	ET7200-M400
Ø44,0	ET7200-M440
Ø46,0	ET7200-M460
Ø50,0	ET7200-M500
Ø54,0	ET7200-M540
Ø57,0	ET7200-M570
Ø62,0	ET7200-M620

## Crimping machine accessories

Meet your unique demands for faster, more efficient, or more accurate assembly production by customizing your machines with our high-quality accessories.

### ET5040C-0045

#### Front die storage rack

The ET5040C-0045 die storage rack offers a convenient place to store your tooling in front of the crimper.

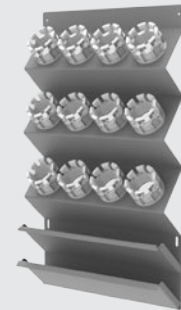

### ET5040C-0046

#### Quick die change storage rack

The ET5040-0046 is optimal solution for wall mounting

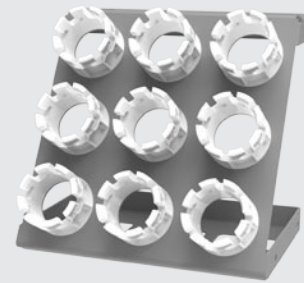

### ET5040C-0047

#### Mobile die storage rack

The ET5040C-0047 mobile die storage rack enables easy work with two side storage, with easy moving around.



### ET5040C-0048

#### Table and quick die change storage rack

The ET5040C-0048 offers a complete solution for the storage and assembly of the dies.



# Crimping machine accessories

## ET5040C-0020

### Foot pedal

The ET5040C-0020 foot pedal is for machines with a controller. Acting like a dual foot switch, this pedal enables you to perform crimp head activation and retraction, leaving your hands free to handle the hose and crimping. To activate the foot switch, select the appropriate button on the controller

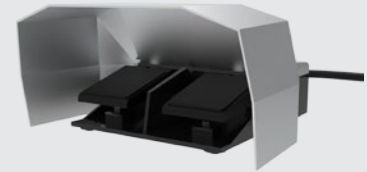

## ET5040C-0019

### Calibration pin

The ET5040C-0019 calibration pin is a tool for machines with a controller that simplifies the calibration process to ensure the crimper is achieving consistent and accurate crimp diameters.

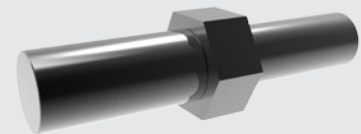

## ET5040C-0006

### Automatic backstop

Use the ET5040C-0006 with the controllers, to enable the closing of the machine automatically.



## ET5040C-0007

### Manual backstop

The ET5040C-0007 manual backstop ensures the right crimp position to ensure assembly crimping happens at the right location.





## Crimping machine accessories ordering options



		ET4100-001	ET4200-001	ET4250-001	ET4300-001	ET4350-001	ET4400-001
<b>Backstop manual ET4200-001-230/380</b>	ET4200C-0001		X				
<b>Backstop manual ET4250-001-012</b>	ET4250C-0001			X			
<b>Backstop manual ET4300-001-230/-380</b>	ET4300C-0001				X	X	
<b>Backstop manual ET4400-001-230/-380</b>	ET4400C-0001						X
<b>Backstop automatic ET4400-001-230/-380</b>	ET4400C-0002						X
<b>Backstop manual ET4500-001-230/-380</b>	ET4500C-0001						
<b>Backstop automatic ET4500-001-230/-380</b>	ET4500C-0002						
<b>Backstop manual ET4500-002-230/-380 with Controller</b>	ET4500C-0003						
<b>Backstop automatic ET4500-002-230/-380 with Controller</b>	ET4500C-0004						
<b>Backstop manual ET5020-001-380 with Controller</b>	ET5020C-0001						
<b>Backstop automatic ET5020-001-380 with Controller</b>	ET5020C-0002						
<b>Backstop manual ET5025-001-380 with controller</b>	ET5025C-0001						
<b>Backstop automatic ET5025-001-380 with Controller</b>	ET5025C-0002						
<b>Backstop automatic ET5070-001-380 with Controller</b>	ET5040C-0006						
<b>Backstop manual ET5070-001-380 with Controller</b>	ET5040C-0007						
<b>Calibration tool for machine with Controller</b>	ET5040C-0019						
<b>Foot pedal for machine with Controller</b>	ET5040C-0020						
<b>Die set storage to put in front of crimper</b>	ET5040C-0045						
<b>Die set storage to put in front of crimper in combination with ET5040C-0048</b>	ET5040C-0046		X	X	X	X	X
<b>Mobile storage rack for dies set of type ET7200-M*** / ET7300-M*** / ET7400-M*** / ET7500-M***</b>	ET5040C-0047		X	X	X	X	X
<b>Table top rack</b>	ET5040C-0048	X	X	X	X	X	X

## Crimping machine accessories ordering options



		ET4500-001	ET4500-002	ET5020-001	ET5025-001	ET5070-001
<b>Backstop manual ET4200-001-230/380</b>	ET4200C-0001					
<b>Backstop manual ET4250-001-012</b>	ET4250C-0001					
<b>Backstop manual ET4300-001-230/-380</b>	ET4300C-0001					
<b>Backstop manual ET4400-001-230/-380</b>	ET4400C-0001					
<b>Backstop automatic ET4400-001-230/-380</b>	ET4400C-0002	X				
<b>Backstop manual ET4500-001-230/-380</b>	ET4500C-0001	X				
<b>Backstop automatic ET4500-001-230/-380</b>	ET4500C-0002		X			
<b>Backstop manual ET4500-002-230/-380 with Controller</b>	ET4500C-0003		X			
<b>Backstop automatic ET4500-002-230/-380 with Controller</b>	ET4500C-0004			X		
<b>Backstop manual ET5020-001-380 with Controller</b>	ET5020C-0001			X		
<b>Backstop automatic ET5020-001-380 with Controller</b>	ET5020C-0002					
<b>Backstop manual ET5025-001-380 with controller</b>	ET5025C-0001				X	
<b>Backstop automatic ET5025-001-380 with Controller</b>	ET5025C-0002				X	
<b>Backstop automatic ET5070-001-380 with Controller</b>	ET5040C-0006					X
<b>Backstop manual ET5070-001-380 with Controller</b>	ET5040C-0007		X	X		X
<b>Calibration tool for machine with Controller</b>	ET5040C-0019		X	X	X	X
<b>Foot pedal for machine with Controller</b>	ET5040C-0020	X	X	X	X	X
<b>Die set storage to put in front of crimper</b>	ET5040C-0045				X	X
<b>Die set storage to put in front of crimper in combination with ET5040C-0048</b>	ET5040C-0046	X	X	X		
<b>Mobile storage rack for dies set of type ET7200-M*** / ET7300-M*** / ET7400-M*** / ET7500-M***</b>	ET5040C-0047				X	X
<b>Table top rack</b>	ET5040C-0048	X	X	X	X	X

## Cutting machines

# Cutting machines

Efficient, precise and durable, our high-quality blades will accelerate your productivity. While using appropriate blades generates less smoke, debris, and heat—which can damage the final product—our offerings are also very cost-effective, lasting up to 7X longer than market alternatives.

We offer several types of cutting blades to meet the most common customer use cases, including slotted, and plated variants. Please check which blade we recommend for use with each machine



### Unique drive motor with double bearings and oversized shafts

- A larger shaft enables a higher cutting force, enabling you to work faster and generate a more saleable product
- Maximizes motor life, giving you the lowest cost of ownership in the market
- Longer time between blade sharpening increases productivity
- Reduces scrap with straight cuts for less shopfloor contamination and more cost-effective products



### German-quality steel blades

- Long-lasting high-quality steel blades lower cost of ownership by enabling faster cutting, as well as less debris, smoke, and heat that can impact hose performance. This also reduces the risk of hose rubber and wire separating



### Compact design

- Ideal for a mobile service



### Safety features

- Safety motor brake meeting DIN CE standard requiring the blade to stop turning in 10 seconds
- Security shield

## Cutting machines

## ET9400

### Mobile cutting machine

Portable, easy to use, and designed for maximum safety, the ET9400 is a manual hose cutting machine for workshop use that also enables cost-effective field servicing. With a 3 kW drive, the ET9400 is suitable for hydraulic hoses up to 1¼" in size. It is compatible with the following blades:

- **ET9400C-275-SL** (275 x 3 x 30mm)
- **ET9400C-275-C** (275 x 3 x 30mm)

Machine Part Number	ET9400-275-380
Feed	manual
production_hose cutting diameter 4-Spiral / 6-Spiral	-12 / 3/4"
workshop_hose cutting diameter 4-Spiral / 6-Spiral	-20 / 1 1/4"
industrial_hose cutting diameter braided	-32 / 2"
Cutting blade	ET9400C-275-SL ET9400C-275-C



#### Specifications

##### Dimensions:

540mmx440mmx300 mm

**Suction diameter:** 80mm

**Weight:** 50 kg

**Noise:** 90 dBA

**Electric drive:** 3kW 3VAC (Brake motor)

#### Features & Benefits

- Manual feed
- For onsite service
- Small volumes and smaller hoses

## ET9500 and ET9550

### Workshop cutting machine

Designed for workshop use, our manual ET9500 and pneumatic ET9550 cutting machines support a wide range of the most common hose sizes at a reasonable price. They are suitable for hydraulic hoses up to 2" and a model that supports 3" industrial hoses is also available. It is compatible with the following blades:

- **ET9500C-350-C** (350 x 3 x 30mm)

Machine Part Number	ET9500-350-380	ET9550-350-380
Feed	manual	pneumatic
Production_hose cutting diameter 4-Spiral / 6-Spiral	-20 / 1 1/4"	-20 / 1 1/4"
Workshop_hose cutting diameter 4-Spiral / 6-Spiral	-32 / 2"	-32 / 2"
Industrial_hose cutting diameter braided	-48 / 3"	-48 / 3"
Cutting blade	ET9500C-350-C	ET9500C-350-C



#### Specifications

##### Dimensions (ET9500):

745mmx690mmx430mm

**Suction diameter:** 60mm

**Weight:** 75 kg

**Noise:** 90 dBA

**Electric drive:** 4,6kW 3VAC (Brake motor)

##### Dimensions (ET9550):

820mm x 785mm x 755 mm

**Suction diameter:** 60mm

**Weight:** 110 kg

**Noise:** 90 dBA

**Electric drive:** 3,6kW 3VAC (Brake motor)

#### Features & Benefits

- With manual or pneumatic feed

## Cutting machines

# ET9600 and ET9650

### Workshop cutting machine

Designed for workshop use, our manual ET9500 and pneumatic ET9550 cutting machines support a wide range of the most common hose sizes at a reasonable price. They are suitable for hydraulic hoses up to 2" and a model that supports 3" industrial hoses is also available. It is compatible with the following blades:

- **ET9600C-400-C** (38x400x400 mm)

Machine Part Number	ET9600-400-380	ET9650-400-380
Feed	manual	pneumatic
Production_hose cutting diameter 4-Spiral / 6-Spiral	-20 / 1 ¼"	-20 / 1 ¼"
Workshop_hose cutting diameter 4-Spiral / 6-Spiral	-32 / 2"	-32 / 2"
Industrial_hose cutting diameter braided	-64 / 4"	-64 / 4"
Cutting blade	ET9600C-400-C	ET9600C-400-C



### Specifications

#### Dimensions (ET9600):

983mm x 760mm x 875mm

**Suction diameter:** 60 mm

**Weight:** 122 kg

**Noise:** 90 dBA

**Electric drive:** 4,6 kW 3 VAC (break motor)

#### Dimensions (ET9650):

983mm x 760mm x 540mm

**Suction diameter:** 60 mm

**Weight:** 140 kg

**Noise:** 90 dBA

**Electric drive:** 4,6 kW 3 VAC (break motor)

### Features & Benefits

- With manual or pneumatic feed
- With wide opening

# ET9700

### Industrial production cutting machine

The ET9700 cutting machine can support high volume manufacturing across a broad range of hose sizes and construction types. With a 7.5 kW motor, the ET9700 is best suited to high-volume manufacturing of 2" hoses, along with a workshop capability for 3" high pressure hoses and 3" industrial hoses. It is compatible with the following blades:

- **ET9700C-520-C** (520x4x40 mm)

Machine Part Number	ET9700-520-380
Feed	pneumatic
production_hose cutting diameter 4-Spiral / 6-Spiral	-32 / 2"
workshop_hose cutting diameter 4-Spiral / 6-Spiral	-48 / 3"
industrial_hose cutting diameter braided	-48 / 3"
Cutting blade	ET9700C-520-C

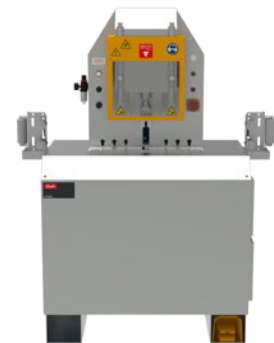

### Specifications

#### Dimensions:

1210 mm x 650 mm x 1650 mm

**Suction diameter:** 100 mm

**Weight:** 245 kg

**Noise:** 80 dBA

**Electric drive:** 7,5 kW / Break motor

### Features & Benefits

- With pneumatic feed
- Low noise of 80 dBA
- High volume production machine

Efficient, precise and durable, our high-quality blades will accelerate your productivity. While using appropriate blades generates less smoke, debris, and heat – which can damage the final product – our offerings are also very cost-effective, lasting up to 7x longer than market alternatives.

We offer several types of cutting blades to meet the most common customer use cases, including slotted, and plated variants. Please check which blade we recommend for use with each machine



## ET9400C-275-SL

### Slotted blade

- Dimensions: 275x3x30 mm

### Features & Benefits

- Unique design incorporates tiny slots to both cut and dissipate heat
- Cleanest cut of all blades
- Best blade on Teflon and LifeSense hose-recommended for any cut
- Same price as Advanced Scalloped blade



## ET9400C-275-C

### Diamond coated blade

- Dimensions: 275x3x30 mm

### Features & Benefits

- Extremely effective cutting all hose styles and sizes:
- -40 six spiral hose cut clean in 15 seconds
- Quite dirty and smoky, just like abrasive blades
- Expensive: ~2 ½ - 3 times steel blades
- Lower cutting force



## ET9500C-350-C

### Diamond coated blade

- Dimensions: 350x3x30 mm



## ET9600C-400-C

### Diamond coated blade

- Dimensions: 400x4x30 mm



## ET9700C-520-C

### Diamond coated blade

- Dimensions: 520x4x40 mm

## Skiving machines

# Skiving machines

Our tooling portfolio offers two highly efficient machines designed to skive all types of hydraulic hoses and fittings on the outside, on the inside, or on the outside and inside in one operation—enabling higher productivity and optimal results.

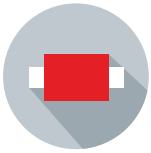

- A larger shaft enables a higher cutting force, enabling you to work faster and generate a more saleable product
- Maximizes motor life, giving you the lowest cost of ownership in the market
- Longer time between blade sharpening increases productivity
- Reduces scrap with straight cuts for less shopfloor contamination and more cost-effective products



- Long-lasting high-quality steel blades lower cost of ownership by enabling faster cutting, as well as less debris, smoke, and heat that can impact hose performance. This also reduces the risk of hose rubber and wire separating

## ET6100KT

### Workshop skiving

The ET6100KT is a two-step workshop skiving machine for all types of hoses and fittings. It is suitable for skiving hoses from 5/8" to 2" on the inside and from 3/16" to 2" on the outside. User-friendly controls and fast change over times optimize the process, while an easy-to-open protective cover and safety flap reduce the risk of injury. The ET6100KT also includes a 2-year warranty.



Machine Part Number	ET6100KT
Skiving diameter (inner diameter)	5/8" (-10) / 2" (-32)
Skiving diameter (outer diameter)	3/16" (-3) / 2" (-32)
Simultaneous internal and external skiving	110 rpm
Engine	0,37 kW
Application area	workshop

### Specifications

#### Dimensions:

440 mmx 440 mmx 545 mm

**Weight:** 35 kg

**Noise:** 60 dBA

### Features & Benefits

- Easy handling via foot pedal
- Good overview to the operation ( Makrolon®- glass window)
- Low setting time - Quick Connector (tooling change)

## ET6110KT

### Workshop skiving

The ET6110KT enables simultaneous internal and external hose skiving, completing the process in one efficient operation for higher productivity. It is suitable for skiving hoses from 3/4" to 2" on the inside and from 1/4" to 2" on the outside. User-friendly controls and fast change over times further optimize the process, with foot pedal motor control allowing the operator to use both hands to guide the hose. An easy-to-open protective cover and safety flap also reduce the risk of injury. The ET6110KT includes a 2-year warranty.



Machine Part Number	ET6110KT
Skiving diameter (inner diameter)	3/4" (-12) / 2 1/2" / (-40)
Skiving diameter (outer diameter)	1/4" (-4) / 2" (-32)
Simultaneous internal and external skiving	392 rpm / 592 rpm
Engine	1,2 / 1,8 kW (3 ~)
Application area	production

### Specifications

#### Dimensions:

780 mmx 620 mmx 550 mm

**Weight:** 70 kg

**Noise:** 60 dBA

### Features & Benefits

- Skiving for inner and outer diameter in one step
- Easy handling via foot pedal
- Good overview to the operation ( Makrolon®- glass window)
- Low setting time - Quick Connector (tooling change)
- Lower drawer with easy access to remove the waste



## Nipple inserters

# Nipple inserters

Our two robust and ergonomic nipple inserters enable faster and easier installation of even very heavy or bent fittings, accelerating productivity and delivering high-performance results.



### Good visibility of the work area

(Makrolon®- glass window) allows clear visibility and strong protection



### Soft clamping

Safe but soft clamping for protective hose clamping



### Ergonomic operations

Adaptable foot pedal control over hose clamping saves time and increases productivity by freeing both of the operator's hands. Lifting eyes also enable easy positioning of the machine.



### Simple-to-use

Safe but soft clamping for protective hose clamping



### Robust design

Drives cost-savings with high resistance to wear and tear and no need for regular maintenance.



### Designed for safety

CE-compliant and includes safety guards for moving components.

## ET6200KT

### Workshop nipple inserter

The ET6200KT is a high-performance nipple inserter for difficult to assemble fittings. With a press force of 6 bar (90 psi), the ET6200KT has a working range of up to 2". It is compatible with all types of hoses and fittings and includes 10 different adapters.



<b>Machine Part Number</b>	<b>ET6200KT</b>
<b>Max. nipple diameter</b>	-32 / 2"
<b>Clamping Force</b>	5,1 kN (6 bar)
<b>Air supply</b>	7 bar (100psi)
<b>Piston movement</b>	100 mm
<b>Application area</b>	Workshop

#### Specifications

##### Dimensions:

600 mm x 810 mm x 310 mm

**Weight:** 35 kg

#### Features & Benefits

- Ideal for workshops
- Manual activation

## ET6210KT

### Industrial production nipple inserter

Suited to both workshop and production environments, the ergonomic ET6210KT eliminates lengthy set-up times. With a press force of 8 bar (116 psi), the ET6210KT has a working range of up to 3", features multi-purpose dies, and is compatible with all types of hoses and fittings. Adaptable foot pedal control over hose clamping also frees both of the operator's hands, while an innovative rapid tool sled enables simple and quick insertion of 90°, 45°, or straight fittings without time-consuming tool changes.



<b>Machine Part Number</b>	<b>ET6210KT</b>
<b>Max. nipple diameter</b>	-48 / 3"
<b>Clamping Force</b>	8 kN (8 bar)
<b>Air supply</b>	7 bar (100psi)
<b>Piston movement</b>	-
<b>Application area</b>	Production

#### Specifications

##### Dimensions:

625 mm x 1185 mm x 320 mm

**Weight:** 100 kg

#### Features & Benefits

- For high volume production
- Foot pedal activation

## Marking machines

# Marking machines

Our tooling portfolio offers two embossing and marking machines that permanently imprint appropriate information onto hose assemblies—enabling easy identification as required by CE standards.



### Good visibility of the work area

(Makrolon®- glass window) allows clear visibility and strong protection



### Soft clamping

Safe but soft clamping for protective hose clamping



### Ergonomic operations

Adaptable foot pedal control over hose clamping saves time and increases productivity by freeing both of the operator's hands. Lifting eyes also enable easy positioning of the machine.



### Simple-to-use

Safe but soft clamping for protective hose clamping



### Robust design

Drives cost-savings with high resistance to wear and tear and no need for regular maintenance.



### Designed for safety

CE-compliant and includes safety guards for moving components.

## ET6300KT

### Manual hose marking

The ET6300KT is a manual marking machine suitable for all hoses and fittings that features an easy-to-use, compact table-top design. With 30 insertable steel characters and a marking area of  $\varnothing$  11.5 - 90 mm, the ET6300KT enables two rows of up to 15 characters each. It comes with a two-year warranty.



Machine Part Number	ET6300KT
Working area	$\varnothing$ 11,5 - 90 mm
Working depth	0,5 mm
Engine	manual

#### Specifications

##### Dimensions:

272 mm x 200 mm x 750 mm

**Weight:** 35 kg

#### Features & Benefits

- Portable marking machine for mobile service
- Easy to handle and flexible to use

## ET6310KT

### Industrial production hose marking

The ET6310KT is a pneumatic marking machine suitable for high-volume production environments and compatible with all hoses and fittings. With 22 insertable steel characters and a marking area of  $\varnothing$  11.5 - 100 mm, the ET6310KT enables two rows of up to 15 characters each. It comes with a two-year warranty.



Machine Part Number	ET6310KT
Working area	$\varnothing$ 11,5 - 90 mm
Working depth	0,5 mm
Engine	pneumatic 7 bar

#### Specifications

##### Dimensions:

600 mm x 454 mm x 500 mm

**Weight:** 80 kg

#### Features & Benefits

- For high volume production

# We're changing the crimping game.

## Mobile crimp tool

We've made it easier to help your customers find the proper crimp spec anytime, anywhere with the new mobile crimp spec tool on PowerSource.

Visit [www.Danfoss.com/crimp](http://www.Danfoss.com/crimp) on your mobile device and follow these steps:

1. **Find your machine**
2. **Select your hose series**
3. **Select your hose size**
4. **Find your fitting style**

Then view your results.  
Add the tool to your home screen for even quicker access.

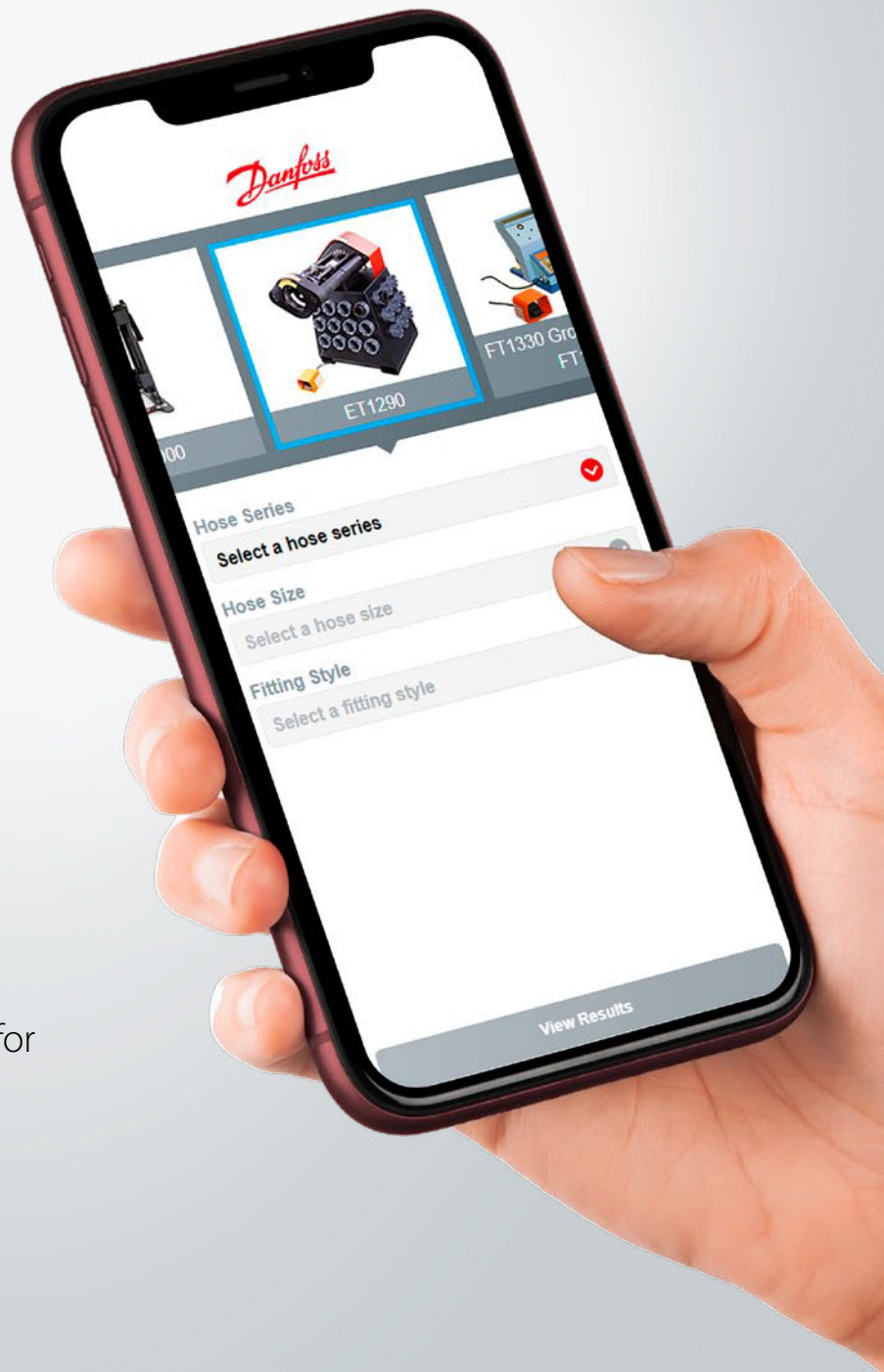



# Danfoss-Powered Solutions:

## On-Site Hose Assembly Workshop Delivers Efficiency!

Introducing - your solution for seamless hydraulic maintenance right at your work site. Our fully equipped mobile workshop bring hydraulic hose replacement and repair capabilities directly to construction, oil and gas, mining, and other sites, minimizing disruptions.

Equipped with specific Danfoss hoses, fittings, and tooling, our workshops enable on-the-spot hose assembly creation and repair, 24/7. No more long waits for shipments or costly travel to find a service provider. With Danfoss On-Site Hose Assembly Workshops, staff can quickly and conveniently repair or replace hose assemblies with exact hose and fitting types used on site.

The customizable configurations of Danfoss on-site hose assembly workshops enable workspace optimization for maximum productivity. Machines can be selected and arranged within the container according to specific hose requirements and production needs.



### Minimize Downtime

Ensures a rapid response, minimizing downtime by providing on-site hose replacement.



### Convenience and Efficiency

We bring the hydraulic hose service to your location, saving you time and ensuring a more efficient solution.



### Cost-Effective

Eliminates the need for expensive equipment transportation and reduces overall downtime.



### Tailored Solutions

We offer customized set up of our mobile workshop, utilizing the most optimal tooling machines and furniture.



### 24/7 Availability

Our On-Site Hose Assembly Workshop may operate around the clock, providing a 24/7 solution.



### Enhances Safety

By quickly addressing hydraulic issues, preventing potential accidents or damage.



### Environmental Responsibility

By offering on-site services we reduce the need for multiple trips, contributing to a more environmentally friendly approach to hydraulic hose maintenance.



Danfoss

## **Safety information**





## Important Safety Information

### Safety Information

#### Danfoss Aeroquip Hose and Fitting Assembly Product Warning

Flexible hose lines offer many advantages over rigid tubing including routing ease, vibration absorption, sound deafening and the ability to accommodate movement of connected components. However, hose lines require caution in use not only to provide long service, but also to guard against potentially dangerous failure.

##### Important

The user should carefully observe the precautions listed in this catalog, including the recommendations on the selection of hose and fittings on the relevant pages, and the pages on fluid compatibility. In addition, care should be taken not to exceed the minimum bend radius listed for each hose size and type in the hose section. Maximum operating pressure should not exceed pressures listed in the hose data. Instructions for assembling fittings to different hose should be followed carefully to ensure the performance of the completed assembly.

#### WARNING

Danfoss fitting tolerances are engineered to match Danfoss' hose tolerances. The use of Danfoss fittings on hose supplied by other manufacturers and/or the use of Danfoss' hose with fittings supplied by other manufacturers may result in the production of unreliable and unsafe hose assemblies and is neither recommended nor authorized by Danfoss or any of its affiliates or subsidiaries.

#### WARNING

Application considerations must be observed in selecting appropriate components for the application of these products contained herein. The failure to follow the recommendations set forth in this catalog may result in an unstable application which may result in serious personal injury or property damage.

DANFOSS OR ANY OF ITS AFFILIATES OR SUBSIDIARIES SHALL NOT BE SUBJECT TO AND DISCLAIMS ANY OBLIGATIONS OR LIABILITIES (INCLUDING BUT NOT LIMITED TO ALL CONSEQUENTIAL, INCIDENTAL AND CONTINGENT DAMAGES) ARISING FROM TORT CLAIMS (INCLUDING WITHOUT LIMITATION NEGLIGENCE AND STRICT LIABILITY) OR OTHER THEORIES OF LAW WITH RESPECT TO ANY HOSE ASSEMBLIES NOT PRODUCED FROM GENUINE AEROQUIP HOSE FITTINGS, HOSE AND AEROQUIP APPROVED EQUIPMENT, AND IN CONFORMANCE WITH DANFOSS' AEROQUIP PROCESS AND PRODUCT INSTRUCTIONS FOR EACH SPECIFIC HOSE ASSEMBLY.

Failure to follow these processes and product instructions and limitations could lead to premature hose assembly failures resulting in property damage, serious injury or death.

##### Routing

If the user follows the recommendations on hose line routing and installation as provided herein, improved safety and longer service life of any hose installation will result.

##### Hose Installation

Proper installation of the hose is essential to the proper operation and safe use of the hose and related equipment. Improper installation of the hose can result in serious injury or property damage caused by spraying fluids or flying projectiles. In order to avoid serious bodily injury or property damage resulting from improper installation of the hose, you should carefully review the information in this catalog regarding hose installation.

Some of the factors you must consider in installing the hose properly are:

- Changes in length
- Proper bend radius
- Protection from high temperature sources
- Elbows and adapters to relieve strain
- Rubbing or abrasion
- Twisting
- Improper hose movement

These factors and the other information in this catalog regarding hose installation should be considered by you before installing the hose. If you have any questions regarding proper hose installation, please contact Danfoss Technical Support at:

DPS\_FC\_EMEA\_TechSupport@danfoss.com

##### Hose Maintenance

Proper maintenance of the hose is essential to the safe use of the hose and related equipment. Hose should be stored in a dry place. Hose should also be visually inspected. Any hose that has a cut or gouge in the cover that exposes the reinforcement should be retired from service. Hoses should also be inspected for kinking or broken reinforcement. If the outside diameter of the hose is reduced by 20% at the spot where it is bent then the hose should be retired from service. Inadequate attention to maintenance of the hose can result in hose leakage, bursting, or other failure which can cause serious bodily injury or property damage from spraying fluids, flying projectiles, or other substances.

## Selection, installation and maintenance of hose and assemblies

The following recommendations on selection, installation and maintenance of hose assemblies were established in SAE J1273. Please read these general instructions carefully. More detailed information on many of these subjects is covered in this catalog.

### 1. Scope

Hose (also includes hose assemblies) has a finite life and there are a number of factors which will reduce its life. This recommended practice is intended as a guide to assist system designers and/or users in the selection, installation, and maintenance of hose.

The designers and users must make a systematic review of each application and then select, install, and maintain the hose to fulfill the requirements of the application. The following are general guidelines and are not necessarily a complete list.

#### WARNING

Improper selection, installation, or maintenance may result in premature failures, bodily injury, or property damage.

### 2. References

#### 2.1 Applicable documents

The following publications form a part of this specification to the extent specified herein. The latest issue of SAE and EN publications shall apply.

##### 2.1.1 SAE, EN and ISO publications

Available from SAE,  
400 Commonwealth Drive, Warrendale,  
PA 15096-0001.  
J516—Hydraulic hose fittings  
J517—Hydraulic hose  
EN853—Hydraulic hose wire braided  
EN854—Hydraulic hose textile reinforced  
EN855—Thermoplastic hydraulic hose  
EN856—Hydraulic hose wire spiral reinforced  
EN857—Hydraulic hose wire braided  
ISO 18752:2022 Rubber hoses and hose assemblies

### 3. Selection

The following is a list of factors which must be considered before final hose selection can be made.

#### 3.1 Pressure

After determining the system pressure, hose selection must be made so that the recommended maximum operating pressure is equal to or greater than the system pressure. Surge pressures higher than the maximum operating pressure will shorten hose life and must be taken into account by the hydraulic designer.

#### 3.2 Suction

Hoses used for suction applications must be selected to insure the hose will withstand the negative pressure of the system.

#### 3.3 Temperature

Care must be taken to insure that fluid and ambient temperatures, both static and transient, do not exceed the limitations of the hose. Special care must be taken when routing near hot manifolds.

#### 3.4 Fluid compatibility

Hose selection must assure compatibility of the hose tube, cover and fittings with the fluid used. Additional caution must be observed in hose selection for gaseous applications.

#### 3.5 Size

Transmission of power by means of pressurized fluid varies with pressure and rate of flow. The size of the components must be adequate to keep pressure losses to a minimum and avoid damage to the hose due to heat generation or excessive turbulence.

#### 3.6 Routing

Attention must be given to optimum routing to minimize inherent problems.

#### 3.7 Environment

Care must be taken to insure that the hose and fittings are either compatible with or protected from the environment to which they are exposed. Environmental conditions such as ultraviolet light, ozone, salt water, chemicals, and air pollutants can cause degradation and premature failure and, therefore, must be considered.

#### 3.8 Mechanical loads

External forces can significantly reduce hose life. Mechanical loads which must be considered include excessive flexing, twist, kinking, tensile or side loads, bend radius, and vibration. Use of swivel-type fittings or adapters may be required to insure no twist is put into the hose. Unusual applications may require special testing prior to hose selection.

#### 3.9 Abrasion

While hose is designed with a reasonable level of abrasion resistance, care must be taken to

protect the hose from excessive abrasion which can result in erosion, snagging and cutting of the hose cover. Exposure of the reinforcement will significantly accelerate hose failure.

#### 3.10 Proper end fitting

Care must be taken to insure proper compatibility exists between the hose and coupling selected based on the manufacturer's recommendations substantiated by testing to industry standards such as SAE J517. End fitting components from one manufacturer are usually not compatible with end fitting components supplied by another manufacturer (i.e., using a hose fitting nipple from one manufacturer with a hose socket from another manufacturer). It is the responsibility of the fabricator to consult the manufacturer's written instructions or the manufacturer directly for proper end fitting componentry.

#### 3.11 Length

When establishing proper hose length, motion absorption, hose length changes due to pressure, as well as hose and machine tolerances must be considered.

#### 3.12 Specifications and standards

When selecting hose, government, industry and manufacturers' specifications and recommendations must be reviewed as applicable.

#### 3.13 Hose cleanliness

Hose components vary in cleanliness levels. Care must be taken to insure that the assemblies selected have an adequate level of cleanliness for the application.

#### 3.14 Electrical conductivity

Certain applications require that hose be nonconductive to prevent electrical current flow. Other applications require the hose to be sufficiently conductive to drain off static electricity. Hose and fittings must be chosen with these needs in mind.

### 4. Installation

After selection of proper hose, the following factors must be considered by the installer.

## General hose selection information

# Selection, installation and maintenance of hose and assemblies

The following recommendations on selection, installation and maintenance of hose assemblies were established in SAE J1273. Please read these general instructions carefully. More detailed information on many of these subjects is covered in this catalog.

### 4.1 Pre-installation inspection

Prior to installation, a careful examination of the hose must be performed. All components must be checked for correct style, size and length. In addition, the hose must be examined for cleanliness, I.D. obstructions, blisters, loose cover, or any other visible defects.

### 4.2 Follow manufacturers' assembly instructions

Hose assemblies may be fabricated by the manufacturer, an agent for or customer of the manufacturer, or by the user. Fabrication of permanently attached fittings to hydraulic hose requires specialized assembly equipment. Field attachable fittings (screw style and segment clamp style) can usually be assembled without specialized equipment although many manufacturers provide equipment to assist in the operation.

SAE J517 hose from one manufacturer is usually not compatible with SAE J516 fittings supplied by another manufacturer. It is the responsibility of the fabricator to consult the manufacturer's written assembly instructions or the manufacturers directly before intermixing hose and fittings from two manufacturers. Similarly, assembly equipment from one manufacturer is usually not interchangeable with that of another manufacturer. It is the responsibility of the fabricator to consult the manufacturer's written instructions or the manufacturer directly for proper assembly equipment. Always follow the manufacturer's instructions for proper preparation and fabrication of hose assemblies.

### 4.3 Minimum bend radius

Installation at less than minimum bend radius may significantly reduce hose life. Particular attention must be given to preclude sharp bending at the hose/fitting juncture.

### 4.4 Twist angle and orientation

Hose installations must be such that relative motion of machine components produces bending of the hose rather than twisting.

### 4.5 Securement

In many applications, it may be necessary to restrain, protect, or guide the hose to protect it from damage by unnecessary flexing, pressure surges,

and contact with other mechanical components. Care must be taken to insure such restraints do not introduce additional stress or wear points.

### 4.6 Proper connection of ports

Proper physical installation of the hose requires a correctly installed port connection while insuring that no twist or torque is put into the hose.

### 4.7 Avoid external damage

Proper installation is not complete without insuring that tensile loads, side loads, kinking, flattening, potential abrasion, thread damage, or damage to sealing surfaces are corrected or eliminated.

### 4.8 System check out

After completing the installation, all air entrapment must be eliminated and the system pressurized to the maximum system pressure and checked for proper function and freedom from leaks.

**NOTE:** Avoid potential hazardous areas while testing.

## 5. Maintenance

Even with proper selection and installation, hose life may be significantly reduced without a continuing maintenance program. Frequency should be determined by the severity of the application and risk potential. A maintenance program should include the following as a minimum.

### 5.1 Hose storage

Hose products in storage can be affected adversely by temperature, humidity, ozone, sunlight, oils, solvents, corrosive liquids and fumes, insects, rodents and radioactive materials. Storage areas should be relatively cool and dark and free of dust, dirt, dampness and mildew.

### 5.2 Visual inspection

Any of the following conditions requires replacement of the hose: Leaks at fitting or in hose (leaking fluid is a fire hazard). Damaged, cut, or abraded cover (any reinforcement exposed) Kinked, crushed, flattened, or twisted hose Hard, stiff, heat cracked or charred hose Blistered, soft, degraded, or loose cover Cracked, damaged, or badly corroded fittings Fitting slippage on hose

### 5.3 Visual inspection

The following items must be tightened, repaired, or replaced as required:

Leaking port conditions

Clamps, guards, shields

Remove excessive dirt buildup

System fluid level, fluid type, and any air entrapment

### 5.4 Functional test

Operate the system at maximum operating pressure and check for possible malfunctions and freedom from leaks.

**NOTE:** Avoid potential hazardous areas while testing.

### 5.5 Replacement intervals

Specific replacement intervals must be considered based on previous service life, government or industry recommendations, or when failures could result in unacceptable down time, damage, or injury risk.

# Ordering & hose numbering system

## How to order

Accurate processing and prompt delivery of your order depends on easy identification of your requirements. Please order Aeroquip and Winner brand parts using correct part numbers as described in this guide. Inquiries and orders should be directed to your distributor or:

### Danfoss Distribution II

A/S Nordborgvej 81,  
6430  
Nordborg, Denmark  
[www.Danfoss.com/hydraulics](http://www.Danfoss.com/hydraulics)

Inside.Sales.DPS.EMEA@  
danfoss.com

### Part numbers and dash sizes

Dash size designates the nominal size in 16th of an inch. This number immediately follows the part number and is separated from it with a dash.

### Dimensions

Dimensions given in this guide for Aeroquip and Winner products are approximate and should be used for reference only. Exact dimensional information for a given product is subject to change and varying tolerances;

contact Danfoss directly for full current information.

### WARNING

#### Hose assemblies

Danfoss manufactures the terminal ends of our hose fittings to the appropriate requirements established by the SAE or DIN. Therefore, the performance ratings of these hose fittings meet the SAE or DIN requirements. It is possible to order a hose assembly with a fitting terminal end that has a

performance rating lower than the hose rating. When ordering hose assemblies, please keep the connecting end performance rating in mind since this may affect overall hose assembly performance. Hose assembly components (hose and fittings) are easily assembled in the field. However, factory assembled reusable and crimped hose assemblies are available. For complete information, contact Danfoss.

## Numbering system - hydraulic hose

Depending on the production type, hoses will be bundled in pre-defined hose lengths:

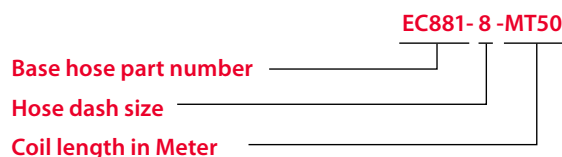

Danfoss is committed to providing pre-defined hose lengths with as few cuts as possible. Nevertheless, please note that following specifications will be valid for the bundled part numbers:

	< MT61	> MT61
<b>Max number of pieces in one bundled coil</b>	Max. 3 pieces	Max. 5 pieces
<b>Shortest length</b>	5 meter	5 meter
<b>Overall length tolerance</b>	+/- 1%	+/- 1%

## Hose selection: Flow capacities

### Flow capacities of hose assemblies at suggested flow velocities

The chart below is designed and provided as an aid in the determination of the correct hose size.

#### Example 1:

A velocity  $V = 8$  m/s and rate of  $Q = 150$  l/min. have been selected. The straight line linking these two values on the outer scales intersects the nominal hose diameter ND20 on the middle scale.

#### Example 2:

A velocity  $V = 5,5$  m/s and flow rate of  $Q = 66$  l/min. have been selected. The straight line linking these two values on the outer scales intersects the nominal hose diameter ND16 on the middle scale. No allowance is incorporated for the resistance of the pipes, elbows and valves viscosity, the effect of temperature on viscosity and other factors.

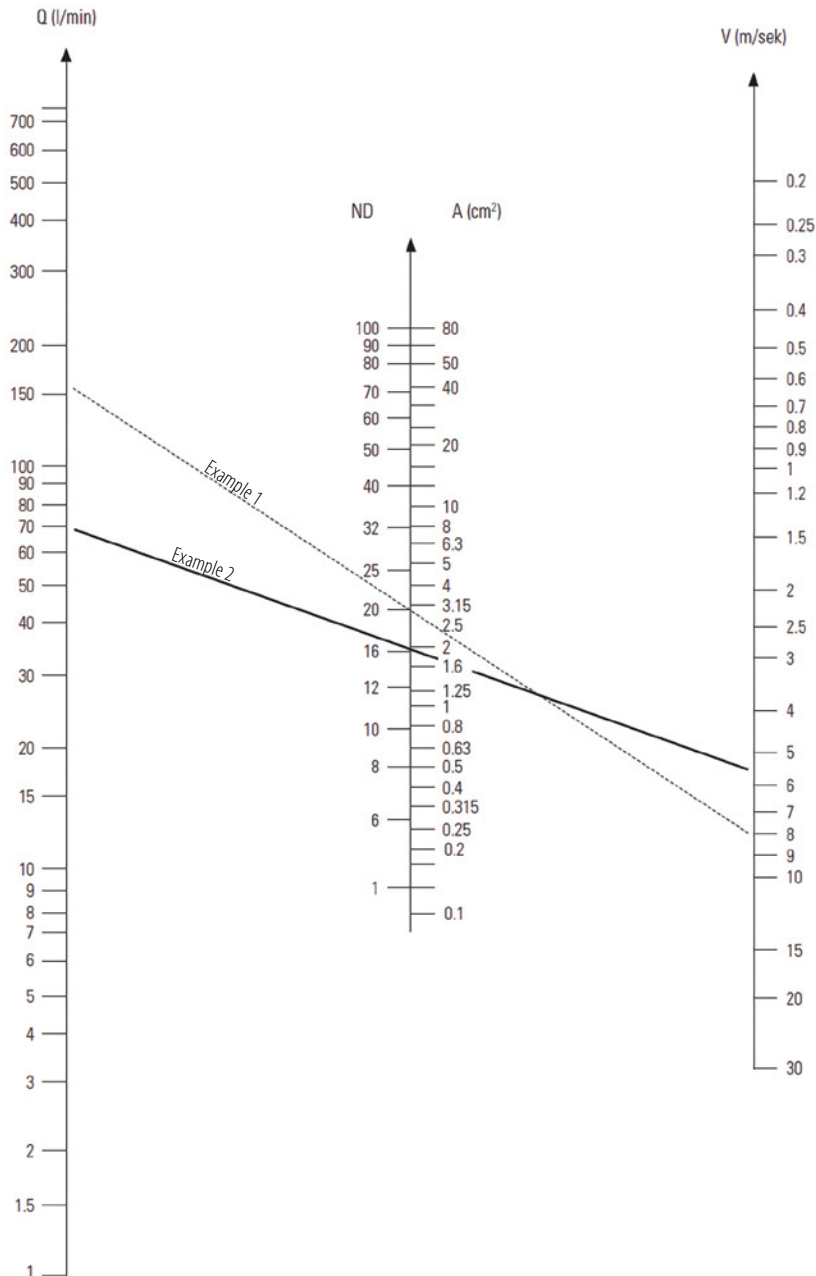

## Hose selection

### Flow capacities pressure drop

#### Hose pressure drop

Pressure drop is expressed in milibar (mb) per 1 metre length of hose (smooth bore) without fittings.

Fluid spec. specific gravity = 0,85. Viscosity = 20 centi stokes (cs) ref MIL-H-5606 at +21°C. Dimensions: mm in bold type inches in light type

Hose pressure drop																					
DN acc. DIN	5	6		8	10		12		16		20		25		32		40		50	60	80
DN (real)	4,8	6,4	6,4	8,0	9,5	10,3	12,7	12,7	15,9	15,9	19,0	22,2	25,4	28,6	31,8	35,0	38,1	46,0	50,8	60,3	76,2
Hose size	-04		-05	-06		-08		-10		-12		-16		-20		-24		-32		-48	-48
l/min. flow	1	242	75,4	75,4																	
litres per	2	466	146	146	66,1																
min	4	996	293	293	133	58,6															
	8	2433	613	613	250	117	85														
	10	3540	880	880	335	144	103	45,4	45,4												
	15		1776	1776	660	273	182	68,6	68,6	27,4	27,4										
	20		3080	3080	1129	462	308	116	116	41,4	41,4	18,1									
	30				2159	887	592	228	228	81,8	81,8	31,8	13,6								
	40				1496	1000	379	379	141	141	50,0	26,3	14,0								
	50					1414	555	555	192	192	75,0	41,1	21,5	12,1							
	60					1938	756	756	263	263	111	55,9	29,6	15,6	9,87						
	70						970	970	373	373	154	71,4	37,4	18,3	13,3	8,51					
	80						1250	1250	475	475	200	89,5	49,1	28,0	16,8	11,0	6,91				
	90						1531	1531	560	560	237	115	66,0	34,1	21,1	13,5	8,50	3,61			
	100								653	653	274	137	73,1	40,8	25,1	15,8	10,0	4,25	2,71		
	125								964	964	393	196	103	59,2	35,6	22,7	14,5	5,78	3,79		
	150										567	273	147	77,4	49,8	31,8	19,4	8,57	5,44		
	175										7,5	349	186	106	60,4	41,0	26,5	11,0	7,12	3,06	
	200										920	431	228	136	83,3	51,4	33,3	13,8	8,63	3,79	
	250											642	347	198	124	78,5	49,9	20,8	13,2	6,01	
	300											864	475	272	162	105	68,2	27,4	17,3	7,77	2,52
	400												832	483	303	177	118	47,7	32,4	13,9	4,54
	500												1159	690	425	250	164	66,0	43,3	19,4	6,38
	600														562	339	222	88,6	57,4	25,8	8,49
	700														733	461	301	120	78,2	34,6	11,2
	800														924	584	383	151	98,4	43,4	13,8
	900														1144	706	468	182	118	53,2	16,2
	1000															841	553	219	140	67,5	19,6

## Hose selection

### Fluid compatibility

This chart indicates the suitability of various elastomers and metals for use with fluids to be conveyed. It is intended as a guide only and is not a guarantee. Final selection of the proper hose style, seal, or material of metal components is further dependent on many factors including pressure, fluid and ambient temperature, concentration, duration of exposure, etc.

#### How to use the chart

1. The chart has separate sections for rating elastomers for use as hose inner tubes and as seals. Ratings for a given elastomer may not always be the same in both sections.
2. Both the elastomer and the metal must be considered when determining suitability of a combination for a hose assembly, adapter with o-ring, swivel joint or coupling.
3. Locate the fluid to be conveyed and determine the suitability of the elastomeric and metal components according to the resistance ratings shown for each.
4. Refer to the inner tube materials groupings under "Hose tube identification".
5. Dimensional and operating specifications for each hose can be found on the catalog pages shown with each hose part number.

6. Information on o-rings and seal options for swivel joints and couplings, and how to specify them, are shown in the respective sections of this catalog.
7. For further details on the products shown in this catalog, and their applications, contact:

**Danfoss**  
 DPS\_FC\_EMEA\_TechSupport@danfoss.com  
[www.Danfoss.com](http://www.Danfoss.com)

#### Resistance key rating

- E** = Excellent – Fluid has little or no effect.  
**G** = Good – Fluid has minor to moderate effect.  
**C** = Conditional – Service conditions should be described to Danfoss Aeroquip for determination of suitability for application.  
**U** = Unsatisfactory

The differences between ratings "E" and "G" are relative.

Both indicate satisfactory service. Where there is a choice, the materials rated "E" may be expected to give better or longer service than those rated "G".

**NOTE:** Special precautions are necessary in gaseous applications due to the potential volume of gaseous fluid in the system. Unless the cover is perforated, hose styles with rubber or thermoplastic covers are not suitable for gases above 250 psi. Hose styles with perforated covers are so noted in their construction descriptions.

#### WARNING

**Compatibility of hose fittings with conveyed fluid is an essential factor in avoiding chemical reactions that may result in release of fluids or failure of the connection with the potential of causing severe personal injury or property damage.**

#### Seal elastomer data

Seal elastomer		Max. operating temperature range
Buna-N†	none	-40°C to +121°C [-40°F to +250°F]
Neoprene	none	-54°C to +100°C [-65°F to +212°F]
EPR (Ethylene Propylene Rubber)/ EPDM	none	-54°C to +149°C [-65°F to +300°F]
Viton*		-29°C to +204°C [-20°F to +400°F]

†Buna-N temperature range -54°C to +107°C [-65°F to +225°F]. Also per MIL-R-6855.

\*Viton is a trademark of The Chemours Company FC, LLC.

#### Hose tube identification

1. Synthetic rubber
2. PTFE
3. Synflex thermoplastic elastomer
4. AQP
5. Special application hose (not included in fluid chart)
  - Fuel
  - LPG
  - Railroad air brake
  - Silicone
  - Truck air brake
  - A/C
6. EPDM rubber

The Fluid Compatibility chart is intended for reference use only.

The information in this chart pertains strictly to material compatibility and is not intended to be used as an application guide. For information on specific applications not included in this catalog, please contact Danfoss Aeroquip.

Note 1 - Rubber-covered hose must be perforated to allow gas to escape.

Note 2 - Due to the widely different additives in these fluids, testing should be done on the actual fluid being considered.

## Fluid compatibility

This chart is intended for reference use only.  
The information in this chart pertains strictly to material compatibility and is not intended to be used as an application guide. For information on specific applications not included in this catalog, please contact Danfoss Aeroquip.

\*Viton is a trademark of The Chemours Company FC, LLC.  
†Hytrell is a registered trademark of E.I. du Pont.  
‡Monel is a registered trademark of Special Metals Corporation group of Companies.  
Note 1 - Rubber-covered hose must be perforated to allow gas to escape.  
Note 2 - Due to the widely different additives in these fluids, testing should be done on the actual fluid being considered.

Fluid	Synthetic rubber (Nitrile)						Thermoplastic elastomer						Special application hose						Metal					
	PTFE		CPA (AQP)		EPDM		Buna-N		Neoprene		EPR		Viton*		Urethane		Hytrell†		Steel	Brass	Stainless steel	Aluminum	Monel‡	
Hose	1	2	3	4	5	6	1	2	3	4	5	6	1	2	3	4	5	6	1	2	3	4	5	6
<b>Acetaldehyde</b>	U	E	C	U	-	G	U	C	C	U	U	G	U	U	U	U	G	G	E	E	E	E	E	
Acetic acid, 10%	U	E	C	C	-	E	U	U	E	G	U	C	U	U	C	U	C	U	U	C	C	U	U	
Acetic acid, glacial	U	E	C	C	-	E	U	U	C	U	U	C	U	U	C	U	C	U	U	C	C	U	C	
Acetone	U	E	G	U	-	E	U	U	G	U	U	G	U	U	G	U	G	E	E	E	E	E	E	
Acetophenone	U	E	-	U	-	E	U	U	E	U	U	-	E	E	E	C	E	E	E	C	C	U	E	
Acetyl acetone	U	E	U	U	-	E	U	U	G	U	U	G	U	C	C	C	C	U	C	C	C	U	C	
Acetyl chloride	U	E	U	U	-	U	U	U	U	E	U	U	C	C	C	U	E	C	C	C	U	E	E	
Acetylene <sup>1</sup>	G	E	G	G	-	E	U	U	G	E	G	G	E	E	E	E	E	E	E	E	E	E	E	
Air, hot (up to +160°F) <sup>1</sup>	E	E	E	E	-	E	E	E	E	E	E	E	E	E	E	E	E	E	E	E	E	E	E	
Air, hot (161°F – 200°F) <sup>1</sup>	C	E	U	E	-	E	G	G	E	E	G	G	E	E	E	E	E	E	E	E	E	E	E	
Air, hot (201°F – 300°F) <sup>1</sup>	U	E	U	C	-	G	U	U	G	E	U	U	E	E	E	E	E	E	E	E	E	E	E	
Air wet, below 160°F <sup>1</sup>	E	E	C	E	-	E	E	E	E	E	G	C	U	U	G	E	E	U	U	G	E	E	E	
Aluminum chloride, 10% aq	E	E	E	E	-	E	E	E	E	E	G	E	U	U	U	U	U	U	U	U	U	U	U	
Aluminum fluoride, 10% aq	E	E	E	U	-	E	E	E	E	E	G	E	U	U	U	E	C	U	U	U	E	C	U	
Aluminum nitrate, 10% aq	E	E	E	C	-	E	E	E	E	E	G	E	U	C	C	C	C	U	C	C	C	U	C	
Aluminum sulfate, 10% aq	E	E	G	E	-	E	E	E	E	E	-	G	U	C	E	C	C	U	C	E	C	U	C	
Alums, 10% aq	E	E	E	E	-	E	E	E	E	E	E	E	U	C	E	C	C	U	C	E	C	U	C	
Ammonia, anhydrous <sup>1</sup>	C	U	U	C	-	E	E	E	E	U	-	-	E	U	E	E	E	E	E	E	E	E	E	
Ammonia, aqueous	G	G	U	C	-	E	E	E	E	U	-	-	E	U	E	E	E	E	E	E	E	E	E	
Ammonium carbonate, 10% aq	U	E	C	U	-	E	U	E	E	U	-	C	U	C	U	C	C	U	C	C	C	U	C	
Ammonium chloride, 10% aq	E	E	C	U	-	E	E	E	E	U	-	-	U	U	C	U	C	U	C	U	C	U	C	
Ammonium hydroxide, 10% aq	U	E	U	U	-	E	C	C	E	C	U	U	G	U	G	U	C	U	C	U	C	U	C	
Ammonium nitrate, 10% aq	E	E	C	U	-	E	E	G	E	U	G	C	G	U	G	U	G	U	G	U	G	U	G	

**Resistance key rating**

- E** = Excellent – Fluid has little or no effect.
- G** = Good – Fluid has minor to moderate effect.
- C** = Conditional – Service conditions should be described to Danfoss (Aeroquip and Winner) for determination of suitability for application.
- U** = Unsatisfactory

Fluid	Synthetic rubber (Nitrile)						Thermoplastic elastomer						Special application hose						Metal					
	PTFE		CPA (AQP)		EPDM		Buna-N		Neoprene		EPR		Viton*		Urethane		Hytrell†		Steel	Brass	Stainless steel	Aluminum	Monel‡	
Hose	1	2	3	4	5	6	1	2	3	4	5	6	1	2	3	4	5	6	1	2	3	4	5	6
Ammonium phosphate, 10% aq	E	E	C	U	-	E	E	E	E	-	G	C	U	C	U	G	C	U	C	G	U	G	G	
Ammonium sulfate/sulfide, 10% aq	E	E	C	U	-	E	E	E	E	U	G	C	U	U	G	U	G	U	U	G	U	G	G	
Amyl acetate	U	E	U	U	-	E	U	U	G	U	U	U	E	E	E	E	E	E	E	E	E	E	E	
Amyl alcohol	G	E	E	C	-	E	G	C	E	G	C	E	G	G	E	G	E	G	G	E	U	G	G	
Aniline, aniline oil	U	E	U	U	-	E	U	U	G	U	U	U	E	U	E	E	E	U	E	G	U	G	G	
Aniline dyes	U	E	U	U	-	E	U	G	G	G	U	U	U	U	C	G	C	G	C	G	U	G	G	
Asphalt, < 200°F	C	E	G	G	-	U	G	C	U	E	G	G	E	E	E	E	E	E	E	E	C	E	E	
IRM 901	E	E	E	E	-	U	E	E	C	E	E	E	E	E	E	E	E	E	E	E	E	E	E	
ASTM #2	E	E	E	E	-	U	E	G	U	E	G	E	E	E	E	E	E	E	E	E	E	E	E	
IRM 903	E	E	E	E	-	U	E	G	U	E	G	E	E	E	E	E	E	E	E	E	E	E	E	
Automatic trans. fluid <sup>2</sup>	G	E	G	G	-	U	E	G	U	E	C	G	E	E	E	E	E	E	E	E	E	E	E	
<b>Barium chloride, 10% aq</b>	E	E	C	C	-	E	E	E	E	E	G	C	U	G	G	G	G	U	G	G	U	G	G	
Barium hydroxide, 10% aq	E	E	G	C	-	E	E	E	E	E	E	G	G	U	G	U	G	U	G	U	G	U	G	
Barium sulfide, 10% aq	E	E	C	C	-	E	E	E	E	E	G	C	U	G	U	G	U	U	U	U	U	U	U	
Benzene, benzol	U	E	U	U	-	U	U	U	U	E	U	C	G	E	E	E	E	E	E	E	E	E	E	
Benzoic acid	U	E	C	U	-	U	U	U	E	E	C	C	U	G	G	G	G	G	G	G	G	G	G	
Benzyl alcohol	U	E	C	U	-	E	U	G	G	E	C	C	E	G	E	G	E	G	E	G	E	G	G	
Biodiesel (<180°F)	G	E	G	C	-	U																		
Biodiesel (>180°F)	C	E	U	U	-	U																		
Black sulfate liquor	G	E	C	C	-	E	C	C	C	E	U	C	E	C	E	C	E	C	E	C	E	U	U	
Blast furnace gas	C	U	C	G	-	U	U	U	U	E	U	C	E	C	E	C	E	U	U	C	E	U	U	
Borax, 10% aq	E	E	G	C	-	E	G	G	E	E	G	E	E	E	E	E	E	E	E	E	E	G	-	
Boric acid, 10% aq	E	E	C	E	-	E	G	G	G	E	G	G	U	G	C	C	C	U	G	C	C	U	C	
Brine	G	E	C	C	-	C	E	G	E	E	G	C	U	G	G	U	G	U	G	G	U	E	E	
Bromine, dry	U	E	U	U	-	U	U	U	U	E	U	U	U	C	U	C	C	U	C	C	U	C	C	
Butane <sup>1</sup>	LPG approved hose only						-	E	C	U	E	-	-	E	E	E	E	E	E	E	E	E	E	E
Butyl acetate	U	E	U	U	-	E	U	U	G	U	U	C	E	E	E	E	E	E	E	E	E	E	E	
Butyl alcohol	E	E	G	G	-	C	E	E	G	E	G	G	G	G	G	G	G	G	G	G	G	G	G	



### Fluid compatibility

This chart is intended for reference use only. The information in this chart pertains strictly to material compatibility and is not intended to be used as an application guide. For information on specific applications not included in this catalog, please contact Danfoss Aeroquip.

\*Viton is a trademark of The Chemours Company FC, LLC.  
 †Hytrell is a registered trademark of E.I. du Pont.  
 ‡Monel is a registered trademark of Special Metals Corporation group of Companies.  
 Note 1 - Rubber-covered hose must be perforated to allow gas to escape.  
 Note 2 - Due to the widely different additives in these fluids, testing should be done on the actual fluid being considered.

**E=Excellent**  
**G=Good**  
**C=Conditional**  
**U=Unsatisfactory**

Fluid	Hose						Seals						Metal					
	Synthetic rubber (Nitrile)		Thermoplastic elastomer		Special application hose		Buna-N	Neoprene	EPR	Viton*	Urethane	Hytrell†	Steel	Brass	Stainless steel	Aluminum	Monel‡	
	PTFE	CPA (AQP)	EPDM	1	2	3												4
Butyl cellosolve	U	E	U	U	-	E	U	U	G	U	U	C	E	E	E	E	E	
Butylene (butene) <sup>1</sup>	C	E	-	C	-	U	C	U	U	E	U	-	E	E	E	E	E	
Butyl stearate	U	E	-	U	-	U	G	U	U	E	-	-	G	G	G	G	G	
Butyraldehyde	U	E	-	U	-	E	U	U	G	U	U	-	E	E	E	E	G	
Calcium acetate, 10% aq	G	E	C	C	-	E	G	G	E	U	U	C	G	G	G	C	G	
Calcium bisulfate, 10% aq	U	E	C	G	-	U	E	E	U	E	G	G	U	C	C	U	U	
Calcium chloride, 10% aq	E	E	E	C	-	E	E	E	E	E	E	E	G	G	G	C	G	
Calcium hydroxide, 10% aq	E	E	C	C	-	E	E	E	E	U	C	G	G	G	U	U	G	
Calcium hydroxide, 10% aq	C	E	C	U	-	E	U	U	E	U	C	U	G	C	U	U	U	
Calcium nitrate, 10% aq	E	E	E	G	-	E	E	E	E	E	E	E	G	G	G	G	G	
Carbitol	G	E	G	C	-	G	G	G	G	U	G	E	E	E	E	E	E	
Carbolic acid (phenol)	U	E	U	U	-	C	U	U	G	E	U	U	U	E	E	-	-	
Carbonic acid	C	E	C	U	-	E	G	E	E	C	C	U	C	E	G	E	E	
Carbon dioxide, dry gas <sup>1</sup>	E	E	E	E	-	E	G	G	E	E	G	E	E	E	E	E	E	
Carbon disulfide	U	E	U	U	-	U	U	U	E	C	C	G	G	G	E	G	G	
Carbon monoxide <sup>1</sup>	E	E	E	E	-	E	G	G	E	E	G	E	E	E	E	E	E	
Carbon tetrachloride	U	E	U	U	-	U	U	U	E	U	U	U	G	G	U	E	E	
Castor oil	E	E	G	E	-	G	E	E	G	E	G	G	E	E	E	E	E	
Cellosolve acetate	U	E	U	U	-	E	U	U	G	U	U	U	U	E	G	E	E	
China wood oil (tung Oil)	E	E	C	C	-	U	G	G	U	E	U	C	E	G	E	E	E	
Chlorine <sup>1</sup>	U	G	U	U	-	U	U	U	U	G	U	U	C	C	C	C	C	
Chloroacetic acid	U	E	U	U	-	E	U	U	G	U	U	U	U	U	U	U	G	

**E=Excellent**  
**G=Good**  
**C=Conditional**  
**U=Unsatisfactory**

Fluid	Hose						Seals						Metal					
	Synthetic rubber (Nitrile)		Thermoplastic elastomer		Special application hose		Buna-N	Neoprene	EPR	Viton*	Urethane	Hytrell†	Steel	Brass	Stainless steel	Aluminum	Monel‡	
	PTFE	CPA (AQP)	EPDM	1	2	3												4
Chloroacetone	U	E	U	U	-	E	U	U	E	U	U	U	G	G	G	U	G	
Chlorobenzene	U	E	U	U	-	U	U	U	G	U	U	U	G	G	G	G	G	
Chloroform	U	E	U	U	-	U	U	U	E	U	U	U	G	G	G	G	G	
O-Chlorophenol	U	E	U	U	-	U	U	U	E	U	U	U	G	G	G	U	G	
Chlosulfonic acid	U	U	U	U	-	U	U	U	U	U	U	U	G	U	G	G	C	
Chrome plating solution	U	E	-	U	-	U	U	U	G	E	U	-	C	U	U	U	U	
Chromic acid	U	E	-	U	-	C	U	U	C	E	U	-	C	U	U	U	U	
Citric acid	G	E	C	G	-	E	E	E	E	E	E	C	C	C	C	C	C	
Coke oven gas	U	E	-	U	-	U	U	U	E	U	-	E	C	E	U	U	U	
Copper chloride, 10% aq	E	E	E	G	-	E	E	E	E	E	G	E	U	U	U	U	U	
Copper cyanide, 10% aq	E	E	-	G	-	E	E	E	E	E	-	E	U	G	U	G	G	
Copper sulfate, 10% aq	E	E	G	G	-	E	E	E	E	E	G	G	U	C	G	U	G	
Cotton seed Oil	E	E	E	G	-	C	E	G	C	E	E	E	E	E	E	E	E	
Creosote (coal tar)	G	E	U	G	-	U	G	C	U	E	U	U	E	C	E	E	E	
Crude oil	G	E	C	E	-	U	E	G	U	E	G	C	G	U	G	U	U	
Cyclohexanol	C	E	C	G	-	U	E	G	U	E	C	C	E	E	E	C	E	
Cyclohexanone	U	E	C	U	-	G	U	U	G	U	G	G	E	E	E	C	E	
Detergent/Water solution	E	E	C	G	-	E	E	E	E	E	C	C	G	E	E	E	E	
Diacetone alcohol (acetol)	U	E	U	U	-	E	U	U	E	U	C	C	E	E	E	E	E	
Dibenzyl ether	U	E	-	U	-	G	U	U	G	U	-	-	G	G	G	G	G	
Diesel oil <sup>2</sup>	G	E	C	G	-	U	E	C	U	E	C	C	E	E	E	E	E	
Diethylamine	C	E	-	C	-	C	G	G	G	U	-	-	E	U	E	-	E	
Diocetyl phthalate (DOP)	U	E	C	C	-	G	U	U	G	G	C	C	E	E	E	E	E	
Dowtherm A&E	U	E	-	U	-	U	U	U	U	E	-	-	G	U	E	E	E	
Ethyl alcohol (Ethanol)	E	E	C	G	-	E	E	E	E	E	C	C	E	E	E	G	E	
Ethyl acetate	U	E	C	U	-	G	U	U	G	U	C	C	E	E	E	E	E	
Ethyl benzene	U	E	-	U	-	U	U	U	E	U	-	E	G	G	G	E	E	
Ethyl cellulose	G	E	U	U	-	G	G	G	G	U	C	C	E	G	G	G	G	
Ethyl chloride	C	E	U	U	-	U	U	U	E	U	U	E	E	E	G	G	G	
Ethylene dichloride	U	E	U	U	-	U	U	U	G	U	U	G	C	G	G	G	G	
Ethylene glycol	E	E	C	G	-	E	E	E	E	E	C	C	U	G	E	E	E	

**Resistance key rating**

- E** = Excellent – Fluid has little or no effect.
- G** = Good – Fluid has minor to moderate effect.
- C** = Conditional – Service conditions should be described to Danfoss (Aeroquip and Winner) for determination of suitability for application.
- U** = Unsatisfactory

## Fluid compatibility

This chart is intended for reference use only. The information in this chart pertains strictly to material compatibility and is not intended to be used as an application guide. For information on specific applications not included in this catalog, please contact Danfoss Aeroquip.

\*Viton is a trademark of The Chemours Company FC, LLC.  
 †Hytrell is a registered trademark of E.I. du Pont.  
 ‡Monel is a registered trademark of Special Metals Corporation group of Companies.  
 Note 1 - Rubber-covered hose must be perforated to allow gas to escape.  
 Note 2 - Due to the widely different additives in these fluids, testing should be done on the actual fluid being considered.

Fluid	Hose						Seals						Metal					
	Synthetic rubber (Nitrile)		Thermoplastic elastomer CPA (AQP)		Special application hose EPDM		Buna-N Neoprene		EPR Viton*		Urethane Hytrell†		Steel Brass		Stainless steel Aluminum		Monel‡	
	1	2	3	4	5	6	1	2	3	4	5	6	1	2	3	4	5	6
<b>Ferric chloride, 10% aq</b>	E	E	-	G	-	E	E	G	E	E	-	-	U	U	U	U	U	U
Ferric nitrate, 10% aq	E	E	C	E	-	E	E	E	E	E	C	C	U	U	G	U	U	U
Ferric sulfate, 10% aq	E	E	C	E	-	E	G	G	G	E	C	C	U	U	E	U	U	U
Formaldehyde	U	E	C	U	-	E	C	C	G	G	C	C	E	E	E	G	G	G
Formic acid	G	E	U	C	-	E	C	G	E	U	U	U	C	C	C	C	C	C
Fuel oil	E	E	G	E	-	U	E	G	U	E	G	G	E	E	E	E	E	E
Furfural	U	E	-	U	-	G	C	C	G	U	U	-	G	G	G	G	G	G
<b>Gallic acid, solution</b>	G	E	-	C	-	G	G	G	G	E	U	-	U	-	G	C	G	G
Gasoline <sup>2</sup>	G	E	E	G	-	U	E	C	U	E	E	E	E	E	E	E	E	E
Gasohol <sup>2</sup>	G	E	G	C	-	U	G	G	U	E	E	E	E	E	E	G	E	E
Glycerine/ Glycerol	E	E	E	E	-	E	E	E	E	E	G	E	E	G	E	E	E	E
Green sulfate liquor	G	E	-	U	-	E	G	G	E	E	-	-	U	U	E	U	U	U
<b>Helium<sup>1</sup></b>	E	G	C	E	-	E	E	E	E	E	E	E	E	E	E	E	E	E
Heptane	E	E	E	C	-	U	E	G	U	E	G	G	E	E	E	E	E	E
Hexaldehyde	U	E	-	U	-	E	U	G	G	U	U	-	G	G	E	E	G	G
Hexane	E	E	E	E	-	U	E	G	U	E	G	G	E	E	E	E	E	E
Hydraulic oils <sup>2</sup>																		
Ester blend	C	E	C	G	-	C	E	U	U	E	U	E	E	E	E	E	E	E
Phos. Ester/ petroleum blend	U	E	C	U	-	U	U	U	U	C	U	G	E	E	E	E	E	E
Silicone oils	E	E	E	E	-	E	E	E	E	E	E	E	E	E	E	E	E	E
Straight petroleum base	E	E	E	E	-	U	E	G	U	E	E	E	E	E	E	E	E	E
Straight phosphate ester	U	E	C	U	-	E	U	U	G	C	U	G	E	E	E	E	E	E
Water glycol	E	E	C	G	-	E	E	E	E	E	C	C	E	E	E	G	E	E
Water petroleum emulsion	E	E	C	G	-	U	E	G	U	E	C	C	E	E	G	E	E	E
Hydrobromic acid	U	E	U	U	-	G	U	U	E	E	U	U	E	U	E	E	U	U
Hydrochloric acid, cold	U	E	U	U	-	G	U	U	G	E	U	U	U	U	U	U	U	U
Hydrocyanic acid	C	E	-	U	-	E	C	C	E	E	-	-	E	E	G	E	G	G
Hydrofluoric acid	U	E	U	U	-	U	U	U	C	U	U	U	U	U	U	U	U	C
Hydrofluorosilic acid	E	E	-	G	-	G	G	G	E	E	-	-	U	U	U	U	U	U
Hydrogen <sup>1</sup>	G	C	G	G	-	E	E	E	E	E	E	E	E	E	E	E	E	E
Hydrogen peroxide	C	E	G	C	-	G	G	G	E	G	G	U	U	G	E	U	U	U
Hydrogen sulfide, dry	C	C	C	U	-	E	U	G	E	U	-	G	E	G	G	G	G	G
Isocyanate	U	E	U	U	-	U	U	U	G	E	U	U	G	-	G	-	-	-
Iso octane	G	E	E	G	-	U	E	G	U	E	G	E	E	E	E	E	E	E
Isopropyl acetate	U	E	C	U	-	C	U	U	G	U	U	C	E	-	E	E	E	E
Isopropyl alcohol	G	E	C	G	-	E	G	G	E	E	U	C	E	E	E	G	E	E
Isopropyl ether	G	E	-	C	-	U	G	U	U	U	C	-	G	G	G	-	-	-
<b>JP-4, JP-5</b>	E	E	G	E	-	U	E	U	U	E	U	G	E	E	E	E	E	E
<b>Kerosene</b>	G	E	G	E	-	U	E	U	U	E	U	G	E	E	E	E	E	E
<b>Lacquer/ lacquer solvents</b>	U	E	U	U	-	E	U	U	U	U	U	G	U	E	E	E	E	E
Lime sulfur	U	E	C	U	-	E	U	E	E	E	C	C	G	U	G	-	U	U
Linseed oil	E	E	G	G	-	U	E	G	U	E	G	G	E	E	E	E	E	E
LPG <sup>1</sup>	LPG approved hose only						E	G	U	E	-	-	E	E	E	E	E	E
Lubricating oils <sup>2</sup>	See hydraulic oils						See hydraulic oils						See hydraulic oils					
<b>Magnesium chloride, 10% aq</b>	E	E	C	E	-	E	E	E	E	E	C	C	E	C	C	G	G	G
Magnesium hydroxide, 10% aq	G	E	C	G	-	E	G	G	E	E	C	C	E	G	E	G	G	G
Magnesium sulfate, 10% aq	E	E	C	E	-	E	E	E	E	E	C	C	E	E	E	E	E	E
Maleic acid	U	E	C	C	-	G	U	U	U	E	C	C	E	G	G	G	G	G
Maleic anhydride	U	E	C	U	-	C	U	U	U	E	C	C	G	U	E	G	E	E
Malic acid	G	E	-	G	-	U	G	G	U	G	-	-	U	-	E	G	E	E
Mercuric chloride	G	E	E	G	-	G	E	E	E	E	E	E	U	U	U	U	U	U
Mercury	E	E	E	E	-	E	E	E	E	E	E	E	E	E	E	U	U	G
Methanol	E	E	C	E	-	E	G	G	E	U	C	C	G	G	E	C	E	E

**Resistance key rating**

- E** = Excellent – Fluid has little or no effect.
- G** = Good – Fluid has minor to moderate effect.
- C** = Conditional – Service conditions should be described to Danfoss (Aeroquip and Winner) for determination of suitability for application.
- U** = Unsatisfactory

## Fluid compatibility

This chart is intended for reference use only. The information in this chart pertains strictly to material compatibility and is not intended to be used as an application guide. For information on specific applications not included in this catalog, please contact Danfoss Aeroquip.

\*Viton is a trademark of The Chemours Company FC, LLC.  
 †Hytrell is a registered trademark of E.I. du Pont.  
 ‡Monel is a registered trademark of Special Metals Corporation group of Companies.  
 Note 1 - Rubber-covered hose must be perforated to allow gas to escape.  
 Note 2 - Due to the widely different additives in these fluids, testing should be done on the actual fluid being considered.

**E**=Excellent  
**G**=Good  
**C**=Conditional  
**U**=Unsatisfactory

Fluid	Hose						Seals						Metal					
	1	2	3	4	5	6	Buna-N	Neoprene	EPR	Viton*	Urethane	Hytrell†	Steel	Brass	Stainless steel	Aluminum	Monel‡	
Methyl bromide	C	E	U	U	-	U	G	U	U	E	U	U	E	E	G	U	E	
Methyl chloride	U	E	U	U	-	U	U	U	U	E	U	U	E	E	E	U	G	
Methyl butyl ketone	U	E	U	U	-	E	U	U	E	U	C	C	E	E	E	-	E	
Methyl ethyl ketone	U	E	U	U	-	E	U	U	E	U	U	G	G	G	G	G	G	
Methylene chloride	U	E	U	U	-	U	U	U	U	G	U	U	G	G	G	G	G	
Methyl isobutyl ketone	U	E	U	U	-	E	U	U	U	U	U	U	G	G	G	G	G	
Methyl isopropyl ketone	U	E	U	C	-	E	U	U	U	U	U	U	G	G	G	G	G	
Methyl salicylate	U	E	-	U	-	C	U	U	C	U	-	-	E	G	G	E	G	
MIL-L2104	E	E	E	E	-	U	E	G	U	E	E	E	E	E	E	-	E	
MIL-H-5606	E	E	E	E	-	U	E	G	U	E	E	E	E	E	E	E	E	
MIL-H-6083	E	E	E	E	-	U	E	E	U	E	E	E	E	E	E	-	E	
MIL-L-7808	G	E	G	G	-	U	G	U	U	E	G	G	G	G	E	-	-	
MIL-L-23699	E	E	-	G	-	U	G	U	U	E	-	-	E	E	E	E	E	
MIL-H-46170	G	E	-	G	-	C	E	G	U	E	-	-	E	E	E	-	E	
MIL-H-83282	G	E	-	G	-	U	E	U	U	E	-	-	E	E	E	-	E	
Mineral oils	E	E	G	E	-	U	E	G	U	E	G	G	E	E	E	E	E	
<b>Naphtha</b>	C	E	G	E	-	U	C	U	U	E	C	G	-	-	-	-	-	
Naphthalene	U	E	U	U	-	U	U	U	U	E	C	G	E	G	E	G	G	
Naphthenic acid	U	E	-	U	-	U	C	U	U	E	-	-	-	G	E	G	G	
Natural gas <sup>1</sup>	LPG approved hose only						E	E	U	E	-	-	G	G	G	G	G	
Nickel acetate, 10% aq	G	C	U	G	-	E	C	C	E	G	U	U	G	C	E	G	E	
Nickel chloride, 10% aq	E	E	U	E	-	E	E	G	E	E	U	U	U	U	G	U	G	
Nickel sulfate, 10% aq	E	E	U	E	-	E	E	E	E	E	U	U	U	G	G	U	G	
Nitric acid, to 10%	U	E	U	U	-	G	U	U	U	E	U	C	U	U	E	U	U	
Nitric acid, over 10%	U	C	U	U	-	U	U	U	U	G	U	U	U	U	E	C	U	
Nitrobenzene	U	E	U	U	-	E	U	U	U	G	U	U	E	G	E	E	E	

### Resistance key rating

**E** = Excellent – Fluid has little or no effect.  
**G** = Good – Fluid has minor to moderate effect.  
**C** = Conditional – Service conditions should be described to Danfoss (Aeroquip and Winner) for determination of suitability for application.  
**U** = Unsatisfactory

**E**=Excellent  
**G**=Good  
**C**=Conditional  
**U**=Unsatisfactory

Fluid	Hose						Seals						Metal					
	1	2	3	4	5	6	Buna-N	Neoprene	EPR	Viton*	Urethane	Hytrell†	Steel	Brass	Stainless steel	Aluminum	Monel‡	
Nitrogen <sup>1</sup>	E	E	E	E	-	E	E	E	E	E	E	E	E	E	E	E	E	
Octyl alcohol	C	E	E	U	-	U	E	E	E	E	E	E	E	E	E	E	E	
Oleic acid	G	E	G	U	-	U	U	U	C	G	G	E	C	E	G	C	G	
Ortho-dichlorobenzene	U	E	-	U	-	U	U	U	U	E	-	-	G	G	G	G	G	
Oxalic acid, 10% aq	C	E	C	C	-	E	G	G	E	E	C	C	U	C	C	C	C	
Oxygen <sup>1</sup>	U	U	U	U	-	E	-	-	-	-	-	-	G	G	G	G	G	
<b>Palmitic acid</b>	E	E	E	E	-	G	E	G	G	E	-	E	G	-	E	G	G	
Para-dichlorobenzene	U	E	-	U	-	U	U	U	U	E	-	-	G	G	G	G	G	
Pentane <sup>1</sup>	Lpg approved hose only						E	E	U	E	U	G	G	G	E	G	E	
Perchloric acid	U	E	U	U	-	G	E	G	G	E	U	U	U	U	U	U	U	
Per-chloroethylene	U	E	U	U	-	U	U	U	U	E	U	U	C	G	G	E	E	
Petroleum base oils	G	E	E	E	-	U	E	G	U	E	E	E	E	E	E	E	E	
Phenol (carbolic acid)	U	E	U	U	-	U	U	G	E	U	U	U	E	E	E	E	G	
Phosphate ester <sup>2</sup>	U	E	C	U	-	E	U	U	G	C	U	G	E	E	E	E	E	
Phosphoric acid 20%	U	E	U	U	-	E	U	U	G	E	U	U	U	E	U	C	E	
Phosphorous trichloride	U	E	U	U	-	E	U	U	E	E	U	U	C	U	C	E	E	
Potassium Acetate, 10% aq	G	E	-	G	-	E	G	G	E	U	-	-	C	G	C	U	G	
Potassium chloride, 10% aq	E	E	E	E	-	E	E	E	E	E	E	E	E	C	E	U	G	
Potassium cyanide, 10% aq	E	E	E	G	-	E	E	E	E	E	E	E	C	U	G	U	C	
Potassium dichromate, 10% aq	E	E	E	E	-	E	E	E	E	E	E	E	C	C	C	C	C	
Potassium hydroxide, to 10%	G	E	C	C	-	E	G	G	E	G	C	C	G	G	G	U	E	
Potassium hydroxide, over 10%	C	E	U	C	-	E	C	C	E	U	U	U	G	G	G	U	E	
Potassium nitrate, 10% aq	E	E	E	E	-	E	E	E	E	E	E	E	G	E	G	-	-	
Potassium sulfate, 10% aq	E	E	E	E	-	E	E	E	E	E	E	E	-	-	-	-	-	
Propane <sup>1</sup> (liquefied)	LPG approved hose only						C	-	-	-	-	-	E	E	E	E	E	

This chart is intended for reference use only.

The information in this chart pertains strictly to material compatibility and is not intended to be used as an application guide. For information on specific applications not included in this catalog, please contact Danfoss Aeroquip.

\*Viton is a trademark of The Chemours Company FC, LLC.

†Hytrell is a registered trademark of E.I. du Pont.

‡Monel is a registered trademark of Special Metals Corporation group of Companies.

Note 1 - Rubber-covered hose must be perforated to allow gas to escape.

Note 2 - Due to the widely different additives in these fluids, testing should be done on the actual fluid being considered.

## Fluid compatibility

Fluid	Hose						Seals						Metal																	
	Synthetic rubber (Nitrile)		Thermoplastic elastomer		Special application hose		Buna-N		Neoprene		Viton*		Urethane		Hytrell†		Steel		Brass		Stainless steel		Aluminum		Monel‡					
	1	2	3	4	5	6	1	2	3	4	5	6	1	2	3	4	5	6	1	2	3	4	5	6	1	2	3	4	5	6
Propyl acetate	U	E	-	U	-	G	U	U	G	U	-	-	E	-	E	E	E	E	E	E	E	E	E	E	E	E	E	E	E	
Propyl alcohol	E	E	U	E	-	E	E	E	E	E	U	U	E	E	E	E	E	E	E	E	E	E	E	E	E	E	E	E	E	
Propylene <sup>1</sup>	U	E	-	U	-	U	U	U	U	E	-	-	E	E	E	E	E	E	E	E	E	E	E	E	E	E	E	E	E	
<b>Refrigerant R-121</b>	E	-	G	C	-	C	G	E	C	E	E	E	E	E	E	E	E	E	E	E	E	E	E	E	E	E	E	E	E	
Refrigerant R-131	E	-	G	C	-	G	G	E	C	E	E	E	E	E	E	E	E	E	E	E	E	E	E	E	E	E	E	E	E	
Refrigerant R-221	U	C	U	U	-	E	U	E	C	U	U	U	E	E	E	E	E	E	E	E	E	E	E	E	E	E	E	E	E	
Refrigerant R-134a <sup>1</sup>	C	C	U	U	-	E	E	C	U	U	U	E	E	E	E	E	E	E	E	E	E	E	E	E	E	E	E	E	E	
<b>Sewage</b>	G	E	E	G	-	E	E	E	E	E	U	E	G	G	G	G	G	G	G	G	G	G	G	G	G	G	G	G	G	
Silicone oils	G	E	E	G	-	E	E	E	E	E	E	E	E	E	E	E	E	E	E	E	E	E	E	E	E	E	E	E	E	
Soap (water solutions)	E	E	C	E	-	E	E	E	E	E	C	C	E	E	E	E	E	E	E	E	E	E	E	E	E	E	E	E	E	
Sodium acetate, 10% aq	G	U	-	G	-	E	G	G	E	U	-	-	E	E	G	E	E	E	E	E	E	E	E	E	E	E	E	E	E	
Sodium Bicarbonate, 10% aq	E	E	E	E	-	E	E	E	E	E	E	E	E	E	G	E	E	E	E	E	E	E	E	E	E	E	E	E	E	
Sodium borate, 10% aq	E	E	E	E	-	E	E	E	E	E	E	E	E	E	E	E	E	E	E	E	E	E	E	E	E	E	E	E	E	
Sodium carbonate, 10% aq	E	E	E	E	-	E	E	E	E	E	E	E	E	E	G	E	E	E	E	E	E	E	E	E	E	E	E	E	E	
Sodium chloride, 10% aq	E	E	E	G	-	E	E	E	E	E	E	E	U	C	C	C	E	E	E	E	E	E	E	E	E	E	E	E	E	
Sodium cyanide, 10% aq	E	E	E	E	-	E	E	E	E	E	E	E	E	E	-	C	U	U	U	U	U	U	U	U	U	U	U	U	U	U
Sodium hydroxide, to 10%	C	E	G	C	-	E	U	G	E	E	G	G	C	G	C	C	U	U	U	U	U	U	U	U	U	U	U	U	U	U
Sodium hydroxide, over 10%	U	E	C	U	-	E	U	U	G	E	C	C	C	C	C	C	U	U	U	U	U	U	U	U	U	U	U	U	U	U
Sodium hypochlorite, 10% aq	C	E	C	G	-	G	C	C	E	C	C	C	U	U	U	U	U	U	U	U	U	U	U	U	U	U	U	U	U	U
Sodium metaphosphate, 10% aq	E	E	E	E	-	E	E	E	E	E	E	E	E	E	G	G	U	G	G	U	G	U	G	U	G	U	G	U	G	U
Sodium nitrate, 10% aq	G	E	E	G	-	E	G	G	E	-	-	E	G	G	E	E	E	E	E	E	E	E	E	E	E	E	E	E	E	E
Sodium perborate, 10% aq	G	E	-	G	-	E	G	G	E	E	-	-	E	E	C	U	C	U	C	U	C	U	C	U	C	U	C	U	C	U
Sodium peroxide, 10% aq	G	E	-	G	-	G	G	G	E	E	U	-	U	U	C	C	C	C	C	C	C	C	C	C	C	C	C	C	C	C
Sodium phosphates, 10% aq	E	E	E	C	-	E	E	E	E	E	E	E	E	E	E	E	E	E	E	E	E	E	E	E	E	E	E	E	E	E
Sodium silicate, 10% aq	E	E	E	G	-	E	E	E	E	E	E	E	E	E	E	E	E	E	E	E	E	E	E	E	E	E	E	E	E	E
Sodium sulfate, 10% aq	E	E	E	G	-	E	E	E	E	E	E	E	E	E	E	E	E	E	E	E	E	E	E	E	E	E	E	E	E	E
Sodium sulfide, 10% aq	E	E	E	G	-	E	E	E	E	E	E	E	E	E	E	E	E	E	E	E	E	E	E	E	E	E	E	E	E	E
Sodium thiosulfate, 10% aq	G	E	E	G	-	E	G	E	E	E	E	E	E	E	U	U	C	G	E	U	C	G	E	U	C	G	E	U	C	G
Soy bean oil	E	E	G	C	-	U	E	G	U	E	G	G	E	E	E	E	E	E	E	E	E	E	E	E	E	E	E	E	E	E
Stannic chloride	G	E	C	G	-	E	E	G	E	E	C	C	U	U	U	U	U	U	U	U	U	U	U	U	U	U	U	U	U	U
Steam <sup>1</sup> (up to 388°F)	U	E	U	U	-	G	U	U	C	C	U	U	E	E	E	E	E	E	E	E	E	E	E	E	E	E	E	E	E	E
Stearic acid	G	E	G	G	-	G	G	G	E	E	G	G	C	C	E	C	E	C	E	C	E	C	E	C	E	C	E	C	E	C
Stoddard solvent	G	E	U	C	-	U	E	G	U	E	U	U	E	E	E	E	E	E	E	E	E	E	E	E	E	E	E	E	E	E
Styrene	U	E	U	U	-	U	U	U	U	G	U	U	E	E	E	E	E	E	E	E	E	E	E	E	E	E	E	E	E	E
Sulfur, slurry	C	E	G	E	-	E	U	E	E	E	G	G	E	U	G	E	E	U	G	E	U	G	E	U	G	E	U	G	E	U
Sulfur chloride, wet	U	E	-	U	-	U	U	U	U	E	-	-	G	-	G	G	U	G	G	U	G	G	U	G	G	U	G	G	U	G
Sulfur dioxide, dry <sup>1</sup>	U	E	U	U	-	E	U	U	G	E	U	U	E	G	E	U	U	E	G	E	U	G	E	U	G	E	U	G	E	U
Sulfuric acid, to 10%	U	E	U	U	-	E	U	U	E	C	C	U	G	C	U	G	C	U	G	C	U	G	C	U	G	C	U	G	C	U
Sulfuric acid, over 10%	U	E	U	U	-	U	U	U	G	U	U	U	U	U	U	U	U	U	U	U	U	U	U	U	U	U	U	U	U	U
Sulfurous acid	U	E	U	G	-	G	C	C	U	G	U	U	U	U	U	U	U	U	U	U	U	U	U	U	U	U	U	U	U	U
<b>Tannic acid</b>	G	E	G	G	-	E	G	E	E	E	G	G	E	E	E	E	E	E	E	E	E	E	E	E	E	E	E	E	E	E
Tar (Bituminous)	G	E	G	G	-	U	G	U	U	E	G	G	E	G	E	E	E	E	E	E	E	E	E	E	E	E	E	E	E	E
Tartaric acid	E	E	G	E	-	G	E	G	E	E	G	G	E	G	G	U	C	C	E	C	E	C	E	C	E	C	E	C	E	C
Tertiary butyl alcohol	G	E	G	E	-	G	G	G	E	E	G	G	G	G	G	G	G	G	G	G	G	G	G	G	G	G	G	G	G	G
Titanium tetrachloride	U	E	-	U	-	U	C	U	U	E	-	-	E	U	G	U	U	U	U	U	U	U	U	U	U	U	U	U	U	U
Toluene (toluol)	U	E	U	U	-	U	U	U	U	E	U	U	E	U	E	E	E	E	E	E	E	E	E	E	E	E	E	E	E	E

### Resistance key rating

**E** = Excellent – Fluid has little or no effect.

**G** = Good – Fluid has minor to moderate effect.

**C** = Conditional – Service conditions should be described to Danfoss

(Aeroquip and Winner) for determination of suitability for application.

**U** = Unsatisfactory

## Fluid compatibility

Fluid	Hose						Seals						Metal				
	1	2	3	4	5	6	Buna-N	Neoprene	EPR	Viton*	Urethane	Hytrel†	Steel	Brass	Stainless steel	Aluminum	Monel‡
Trichlorethylene	U	E	U	U	-	U	U	U	U	E	U	U	E	G	E	E	E
Tricresyl Phosphate	U	E	U	U	-	E	U	U	E	G	U	U	E	-	C	-	G
Triethanolamine	G	E	U	G	-	E	E	U	E	U	U	U	E	U	E	E	E
Tung Oil	E	E	C	C	-	U	G	G	U	E	U	C	E	G	E	E	E
Turpentine	E	E	G	G	-	U	G	U	U	E	G	G	G	G	G	G	G
Varnish	C	E	G	G	-	U	G	U	U	E	G	G	E	G	E	E	E
Vinyl Chloride	U	E	U	U	-	U	U	U	U	E	U	U	E	U	C	E	E
Water (to +150°F)	E	E	E	G	-	E	E	E	E	E	E	E	C	G	E	G	E
Water (+151°F to +200°F)	C	E	U	C	-	E	E	E	E	U	U	C	G	E	G	E	E
Water (+201°F to +350°F)	U	E	U	U	-	E	U	U	G	G	U	U	C	G	E	G	E
Water Glycol	E	E	C	E	-	E	E	E	E	E	C	C	E	E	E	G	E
Water Petroleum Emulsion <sup>2</sup>	E	E	C	C	-	U	E	G	U	E	C	C	C	E	E	G	E
Xylene	U	E	C	U	-	U	U	U	U	E	U	C	E	E	E	E	E
Zinc Chloride, 10% aq	E	E	E	E	-	E	E	E	E	E	E	E	E	U	U	C	G
Zinc Sulfate, 10% aq	E	E	-	E	-	E	E	E	E	E	-	-	U	C	G	C	G

### Resistance key rating

- E** = Excellent – Fluid has little or no effect.
- G** = Good – Fluid has minor to moderate effect.
- C** = Conditional – Service conditions should be described to Danfoss (Aeroquip and Winner) for determination of suitability for application.
- U** = Unsatisfactory

This chart is intended for reference use only. The information in this chart pertains strictly to material compatibility and is not intended to be used as an application guide. For information on specific applications not included in this catalog, please contact Danfoss Aeroquip.

\*Viton is a trademark of The Chemours Company FC, LLC.

†Hytrel is a registered trademark of E.I. du Pont.

‡Monel is a registered trademark of Special Metals Corporation group of Companies.

Note 1 - Rubber-covered hose must be perforated to allow gas to escape.

Note 2 - Due to the widely different additives in these fluids, testing should be done on the actual fluid being considered.

## Hydraulic fluids & lubricating oils

The following charts are a representative list of fluids and manufacturers. The fluids are grouped under generic “family” heads and arranged alphabetically. For each generic “family” listing we have included maximum fluid temperature recommendations for the six hose classifications on the next pages. Two maximum fluid temperature ratings are listed under designations of “H” and “LP”. The “H” designation is for hydraulic service up to the maximum rated operating pressure of any particular hose in the classification. The “LP” designation is for low-pressure service such as lubricating oil systems or low-pressure hydraulic return lines. The letter “U” in the box indicates unsatisfactory resistance to the fluid type. Fluid temperature ratings are predicated on maximum allowable ambient temperatures as follows:

### Classifications 1 and 3

(Synthetic rubber and thermoplastic elastomer)

“H” fluid temp. ratings: +60°C (+140°F) ambient

“LP” fluid temp. ratings: +82°C (+180°F) ambient

### Classification 2 (PTFE)

“H” fluid temp. ratings: +204°C (+400°F) ambient

“LP” fluid temp. ratings: +204°C (+400°F) ambient

### Classification 4 (CPE-AQP)

“H” fluid temp. ratings: +71°C (+160°F) ambient

“LP” fluid temp. ratings: +121°C (+250°F) ambient

(If “H” fluid temperature is +107°C (+225°F) or less, allowable ambient temperature may be increased to +94°C (+200°F))

**Ambient temperatures in excess of those recommended, in conjunction with maximum fluid temperatures, can materially shorten the service life of the hose.**

**Caution:** The fluid manufacturer’s recommended maximum operating temperature for any specific name brand fluid should be scrupulously observed by the user. These recommended temperatures can vary widely between name brands of different fluid compositions, even though they fall into the same generic “family” of fluids. Exceeding the manufacturer’s recommended maximum temperature can result in fluid breakdown, producing by-products that are harmful to elastomeric products, as well as other materials in the system. If a manufacturer’s recommended maximum temperature for his specific fluid is lower than that for the hose rating, it should take precedence over the hose rating for service usage.

## Hydraulic fluids & lubricating oils (continued)

### Straight petroleum-base

#### Maximum fluid temperature recommendation.

See caution on following page for maximum fluid temperatures and limiting ambient temperatures.

#### Hose classifications (see page 350)

Fluid name	1	2	3	4
H	+94°C (+200°F)	+204°C (+400°F)	+94°C (+200°F)	+149°C (+300°F)
LP	+94°C (+200°F)	+232°C (+450°F)	+94°C (+200°F)	+149°C (+300°F)

Fluid name	1	2	3	4
Aircraft hydraulic oil AA		DTE oils		OC turbine oils
Ambrex oils		Duro		Union ATF Dexron
Arco A.T.F. Dexron		Duro AW		Union ATF type F
Arco A.T.F. dDexron IV				Union C-2 fluid
Arco A.T.F. Yype F		EP hydraulic oils		Union C-P oil
Arco fleet motor		EP industrial oils		Union custom motor oil
Arco H.T.F. C-2 fluid		EP machine oils		Union gas engine oil
Arco H.T.C. 100 fluid		Energol HL68		Union Guardol motor oil
Arco 303 fluid		Energol HLP C68		Union heavy duty motor oil
ATF special		Etna oils		Union hydraulic oil AW
Automatic transmission fluid (Dexron)		Exxon ATF		Union hydraulic tractor fluid
			Quadroil series	Union premium motor oil
			Rando oils	Union S-1 motor oil
Carnea oils		Factovis 52 – Conventional R & O hydraulic fluid	Rando oils HD	Union special motor oil
Citgo amplex			Regal oils R & O	Union super motor oil
Citgo ATF, type F		Gulf harmony AW	Rimula oils	Union torque correction fluid
Citgo ATF, Dexron		Gulf security AW	Rotella oils	Union turbine oil
Citgo extra duty circulating oils mineral oil (Heavy duty)(R & O)		Glide	Rotella T oils	Union turbine Oil XD
Citgo motor oils		Hulburt 27 series	RPM Delo 200 motor oils	Union Unax
Citgo pacemaker series mineral oil (R & O)		Hydraulic series	RPM Delo 300 motor oils	Union Unax AW
Citgo pacemaker t series mineral oil (R & O)		Hydraulic oils	RPM Delo special motor oils	Union Unax R & O
Citgo pacemaker XD series mineral oil (Heavy duty) (R & O)		Hydroil series	Rubilene	Union Unax RX
Citgo sentry		Industron 53 – anti wear hydraulic fluid	Shell brand	Union Unitec motor oil
Citgo tractor hydraulic fluid		Lubrite motor 20W-40	Special motor oils	Univis J13
Conoco 303 fluid		Mobil AFT 210	Sun R & O oils	Univis J26
Custom motor oil		Mobil AFT 220	Suntac HP oils	Univis P32
		Mobilfluid 62	Suntac WR oils	
Dectol R & O oils		Mobilfluid 423	Sunvis 700 oils	
Delo 400 motor oils		Mobil hydraulic oils	Sunvis 800 oils	Vactra oils
Delvac oils		Mobiloil special	Sunvis 900 oils	Vitrea oils
Delvac SHC		Mobiloil super 10W-40	Super hydraulic oils	
Delvac special 10W-30			Supreme motor oils	Way lubricants
Donax T oils		NUTO oils	Tellus oils	
			Teresstic oils	XD-3 motor oils
			Torque fluids	
			Torque fluid 47	
			Torque fluid 56	
			Tractor hydraulic fluid	

## Fluid compatibility

### Hydraulic fluids & lubricating oils (continued)

#### Water and petroleum oil emulsion (fr)

##### Maximum fluid temperature recommendation.

See caution on page 350 for maximum fluid temperatures and limiting ambient temperatures.

Hose classifications (see page 350)				
	1	2	3	4
H	+94°C (+200°F)	+121°C (+250°F)	+66°C (+150°F)	+94°C (+200°F)
LP	+94°C (+200°F)	+121°C (+250°F)	+66°C (+150°F)	+94°C (+200°F)

##### Fluid name

Aqualube	Masol fire resistant fluid
Astrol #587	Meltran FR 900
	Mine guard
Chevron FR Fluid D	Mobilmet S122
Chrysler L-705	
Citgo pacemaker invert FR fluid	Penn drake hydraqua fluid
Conoco FR hydraulic fluid	Permamul FR
	Puro FR fluid
	Pyrogard C
Dasco IFR	Pyrogard D
Duro FR-HD	
	Quintolubric 957 series
Fire resistant hydrafluid	Quintolubric 958 series
Fire resistant hydraulic Fluid B	
FR 3110 hydraulic fluid (invert)	Regent hydrolube #670
Fyre-safe W/O	
	Safoil hydraulic fluid anti-wear
Gulf R & D FR fluid	Sinclair Duro FR-HD
	Solvac 1535G
Houghto-safe 5046	Staysol FR
Houghto-safe 5046W	Sunsaft F
Hulsafe 500	
Hy-chock oil	Union FR fluid
Hydrasol A	Union soluble oil HD
Ironsides #814-A	Veedol auburn FRH
Irus fluid 905	Veedol auburn FRH Concentrate
Kutwell 40	

#### Water and glycol solution

##### Maximum fluid temperature recommendation.

See caution on page 350 for maximum fluid temperatures and limiting ambient temperatures.

Hose classifications (see page 350)				
	1	2	3	4
H	+94°C (+200°F)	+121°C (+250°F)	+66°C (+150°F)	+94°C (+200°F)
LP	+94°C (+200°F)	+121°C (+250°F)	+66°C (+150°F)	+94°C (+200°F)

##### Fluid name

Chem-trend HF-18	Maxmul
Chem-trend HF-20	Maxmul FR
Chevron glycol FR fluids	Melsyn 200
Citgo glycol FR fluids	Melsyn glycol FR
Citgo glycol FR-20 XD	
Citgo pacemaker	Nyvac FR fluid
	Nyvac FR 200 fluid
	Nyvac 20 (WG)
Dasco FR 150	Nyvac 30 (WG)
Dasco FR 200	
Dasco FR 200 B	
Dasco FR 310	Park water glycol hydraulic fluid
	Pennzoil fluid FR 2X
Fyrguard 150	
Fyrguard 200	
Fyre-Safe 225	Quintolubric 700 series
Gulf FR fluid G-200	Santosafe W/G 15
Gulf FR fluid – G series	Santosafe W/G 20
	Santosafe W/G 30
	Standard glycol FR #15
	Standard glycol FR #20
	Standard glycol FR #25
Houghto-safe 271	Ucon hydrolube 150 CP
Houghto-safe 416	Ucon hydrolube 200 CP
Houghto-safe 520	Ucon hydrolube 275 CP
Houghto-safe 525	Ucon hydrolube 300 CP
Houghto-safe 616	Ucon hydrolube 550 CP
Houghto-safe 620	Ucon hydrolube 900 CP
Houghto-Safe 625	Ucon hydrolube 150 DB
Houghto-safe 640	Ucon hydrolube 275 DB
Hydra safe 620	Ucon hydrolube 150 LT
Hydra safe 625	Ucon hydrolube 200 LT
Hydraulic safety fluid 200	Ucon hydrolube 275 LT
Hydraulic safety fluid 300	Ucon hydrolube 300 LT
Hyspin AF-1	Ucon M-1
Hyspin AF-2	Ucon hydrolube 200 NM
Hyspin AF-3	Ucon hydrolube 300 NM

## Hydraulic fluids & lubricating oils (continued)

### Straight phosphate-ester (fr)

#### Maximum fluid temperature recommendation.

See caution on page 350 for maximum fluid temperatures and limiting ambient temperatures.

Hose classifications (see page 350)					
	1	2	3	4	6
H	U	+204°C (+400°F)	+94°C (+200°F)	U	+94°C (+200°F)
LP	U	+204°C (+400°F)	+94°C (+200°F)	U	+94°C (+200°F)

#### Fluid name

FR Fluids	Houghto-Safe 1010
Fyrquel 90	Houghto-Safe 1055
Fyrquel 150	Houghto-Safe 1115
Fyrquel 220	Houghto-Safe 1120
Fyrquel 300	Houghto-Safe 1130
Fyrquel 550	
Fyrquel 1000	Pyrogard 51
Fyrquel 150 R & O	Pyrogard 53
Fyrquel 220 R & O	Pyrogard 55
Fyrquel 550 R & O	
	Safetytex 215
Gulf FR Fluid P-37	Skydraul 500A
Gulf FR Fluid P-40	Skydraul 7000
Gulf FR Fluid P-43	
Gulf FR Fluid P-45	Univis P12
Gulf FR Fluid P-47	

### Silicone oils

#### Maximum fluid temperature recommendation.

See caution on page 350 for maximum fluid temperatures and limiting ambient temperatures.

Hose classifications (see page 350)				
	1	2	3	4
H	+94°C (+200°F)	+204°C (+400°F)	+94°C (+200°F)	+149°C (+300°F)
LP	+121°C (+250°F)	+204°C (+400°F)	+94°C (+200°F)	+149°C (+300°F)

#### Fluid name

Dow Corning 200 Fluid (100CS)	Dow Corning 3-3672
Dow Corning QF1-2023	
Dow Corning 4-3600	

### Ester blend turbine oils

#### Maximum fluid temperature recommendation.

See caution on page 350 for maximum fluid temperatures and limiting ambient temperatures.

Hose classifications (see page 350)				
	1	2	3	4
H	+121°C (+250°F)	+232°C (+450°F)	+94°C (+200°F)	+149°C (+300°F)
LP	+121°C (+250°F)	+232°C (+450°F)	+94°C (+200°F)	+149°C (+300°F)

#### Fluid name

Stauffer Jet I
Stauffer Jet II

### Polyol-ester

#### Maximum fluid temperature recommendation.

See caution on page 350 for maximum fluid temperatures and limiting ambient temperatures.

Hose classifications (see page 350)				
	1	2	3	4
H	-	-	-	-
LP	+121°C (+250°F)	+232°C (+450°F)	+94°C (+200°F)	+149°C (+300°F)

#### Fluid name

Quintolubric 822 Series
-------------------------

### Lubricant compatibility chart

Lubricant	Hose style		
	GH001	FC800	FC802
Mineral oil	Y	*	Y
PAG	Y	Y	Y
Ester oil	Y	Y	Y
Alkylbenzene	*	*	Y

Y = Compatible N = Non-compatible.

\* Contact product support for application review.



## Hose selection

# Hose routing and installation

### 1. Provide for length change.

In straight hose installations, allow enough slack in the hose line to provide for changes in length that will occur when pressure is applied. This change in length can be from +2% to -4%.

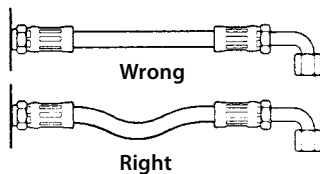

### 2. Avoid twisting and orient properly.

Do not twist hose during installation. This can be determined by the printed layline on the hose. Pressure applied to a twisted hose can cause hose failure or loosening of connections.

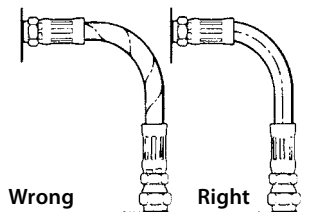

### 3. Protect from hazardous environment.

Keep hose away from hot parts. High ambient temperature will shorten hose life. If you can not route it away from the heat source, insulate it. (See Spring Guards page 250)

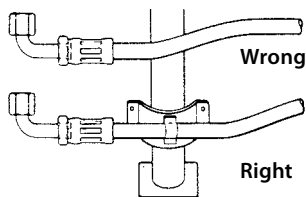

### 4. Avoid mechanical strain.

Use elbows and adapters in the installation to relieve strain on the assembly and to provide easier and neater installations that are accessible for inspection and maintenance.

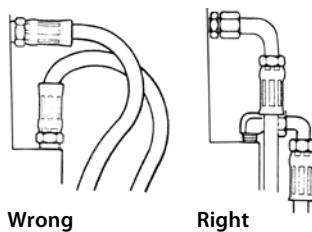

### 5. Use proper bend radius.

Keep the bend radius of the hose as large as possible to avoid collapsing of the hose and restriction of flow. Follow catalog specs on minimum bend radii.

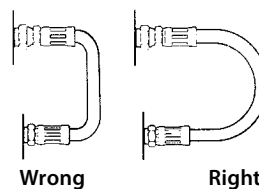

### 6. Use proper bend radius (cont'd).

Minimum bend radius is measured on the inside bend of the hose. To determine minimum bend, divide the total distance between ends (B length) by 2. For example, B=6, minimum bend radius=3.

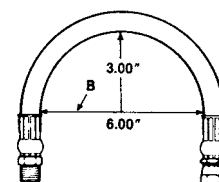

### 7. Secure for protection.

Install hose runs to avoid rubbing or abrasion. Use Aeroquip Hose Clamps to support long runs of hose or to keep hose away from moving parts. It is important that the clamps not allow the hose to move. This movement will cause abrasion and premature hose failure. (See Hose Clamps in the Accessories section)

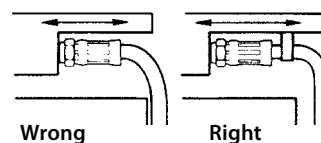

### 8. Avoid improper hose movement.

Make sure relative motion of the machine components produces bending rather than twisting of the hose. Hose should be routed so that the flex is in the same plane as the equipment movement.

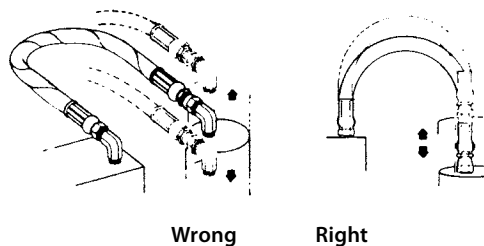

Refer to safety information regarding hose installation on page 336.

## Analyzing failures

Everyone in maintenance encounters hose failures. Normally, there is no problem. The hose is replaced and the equipment goes back in operation. Occasionally the failures come too frequently – the same equipment with the same problems keep popping up. At this point the task is to determine and correct the cause of these repeated failures.

### Improper application

Beginning with the most obvious, the most common cause of hose failures – Improper application – compare the hose specifications with the requirements of the application.

Pay particular attention to the following areas:

- The maximum operating pressure of the hose.
- The recommended temperature range of the hose.
- Whether the hose is rated for vacuum service.
- The fluid compatibility of the hose.

Check all of these areas against the requirements of the application. If they don't match up, you need to select another hose. It's a good idea at this point to call on your local hose distributor for assistance in selecting the proper hose. Danfoss' distributors, for example, are well equipped to perform this service for you.

Distributor personnel attend special training courses in hydraulics and hose application conducted by the company. Or, if your problem is particularly difficult, the distributor can call on the services of Danfoss' field engineering staff. The company will send in a hose and hydraulic specialist to study the problem and come up with a solution.

### Improper assembly and installation

The second major cause of premature hose failure is improper assembly and installation procedures. This can involve anything from using the wrong fitting on a hose, to poor routing of the hose.

Danfoss provides excellent training material that you can use to combat this problem. A little time spent in training your maintenance people could pay big dividends in reduced downtime.

Contact Danfoss to register for a training session today.

### External damage

External damage can range from abrasion and corrosion, to hose that is crushed by a lift truck. These are problems that can normally be solved simply once the cause is identified. The hose can be re-routed or clamped, or a fire sleeve or abrasion guard can be used.

In the case of corrosion, the answer may be as simple as changing to a hose with a more corrosion resistant cover or re-routing the hose to avoid the corrosive element.

### Faulty equipment

Too frequent or premature hose failure can be the symptom of a malfunction in your equipment. This is a factor that should be considered since prompt corrective action can sometimes avoid serious and costly equipment breakdown. Reprints of an article on "Troubleshooting hydraulic systems," which tells you how to spot problems in a hydraulic system are available from Danfoss.

### Faulty hose

Occasionally a failure problem will lie in the hose itself. The most likely cause of a faulty rubber hose is old age. Check the lay line on the hose to determine the date of manufacture. (2Q99 means second quarter 1999.) The hose may have exceeded its recommended shelf life. If you suspect that the problem lies in the manufacture of the hose (and don't jump to this conclusion until you have exhausted the other possibilities) contact your distributor. Given effective quality control methods, the odds of a faulty batch of hose being released for sale are extremely small. So make sure that you haven't overlooked some other problem area.

## Analyzing failures

A physical examination of the failed hose can often offer a clue to the cause of the failure. Following are 22 symptoms to look for along with the conditions that could cause them:

**1. Symptom:** The hose tube is very hard and has cracked.



**Cause:** Heat has a tendency to leach the plasticizers out of the tube. This is a material that gives the hose its flexibility or plasticity. Aerated oil causes oxidation to occur in the tube. This reaction of oxygen on a rubber product will cause it to harden. Any combination of oxygen and heat will greatly accelerate the hardening of the hose tube. Cavitation occurring inside the tube would have the same effect.

**2. Symptom:** The hose is cracked both externally and internally but the elastomeric materials are soft and flexible at room temperature.



**Cause:** The probable reason is intense cold ambient conditions while the hose was flexed. Most standard hoses are rated to  $-40^{\circ}\text{C}$  ( $-40^{\circ}\text{F}$ ). Some hoses are rated at  $-49^{\circ}\text{C}$  ( $-55^{\circ}\text{F}$ ). Military specified hoses are generally rated to  $-54^{\circ}\text{C}$  ( $-65^{\circ}\text{F}$ ). PTFE hose is rated to  $-73^{\circ}\text{C}$  ( $-100^{\circ}\text{F}$ ). Some Everflex Polyon thermoplastic hoses are rated at  $-54^{\circ}\text{C}$  ( $-65^{\circ}\text{F}$ ).

**3. Symptom:** The hose has burst and examination of the wire reinforcement after stripping back the cover reveals random broken wires the entire length of the hose.



**Cause:** This would indicate a high frequency pressure impulse condition. SAE impulse test requirements for a double wire braid reinforcement are 200,000 cycles at 133% of recommended working pressure. The SAE impulse test requirements for a four spiral wrapped reinforcement (100R12) are 500,000 cycles at 133% maximum operating and at  $+121^{\circ}\text{C}$  ( $+250^{\circ}\text{F}$ ). If the extrapolated impulses in a system amount to over a million in a relatively short time a spiral reinforced hose would be the better choice.

Analyzing failures

Analyzing failures

**4. Symptom:** The hose has burst, but there is no indication of multiple broken wires the entire length of the hose. The hose may have burst in more than one place.



**Cause:** This would indicate that the pressure has exceeded the minimum burst strength of the hose. Either a stronger hose is needed or the hydraulic circuit has a malfunction which is causing unusually high pressure conditions.

**5. Symptom:** Hose has burst. An examination indicates the wire braid is rusted and the cover has been cut, abraded or deteriorated badly.



**Cause:** The primary function of the cover is to protect the reinforcement. Elements that may destroy or remove the hose covers are:

1. Abrasion
2. Cutting
3. Battery acid
4. Steam cleaners
5. Chemical cleaning solutions
6. Muriatic acid (for cement clean-up)
7. Salt water
8. Heat
9. Extreme cold

Once the cover protection is gone the wire reinforcement is susceptible to attack from moisture or other corrosive matter.

**6. Symptom:** Hose has burst on the outside bend and appears to be elliptical in the bent section. In the case of a pump supply line, the pump is noisy and very hot. The exhaust line on the pump is hard and brittle.

**Cause:** Violation of the minimum bend radius is most likely the problem in both cases. Check the minimum bend radius and make sure that the application is within specifications. In the case of the pump supply line partial collapse of the hose is causing the pump to cavitate creating both noise and heat. This is a most serious situation and will result in catastrophic pump failure if not corrected.

**7. Symptom:** Hose appears to be flattened out in one or two areas and appears to be kinked. It has burst in this area and also appears to be twisted.



**Cause:** Torquing of a hydraulic control hose will tear loose the reinforcement layers and allow the hose to burst through the enlarged gaps between the braided plaits of wire strands. Use swivel fittings or joints to be sure there is no twisting force on a hydraulic hose.

**8. Symptom:** Hose type has broken loose from the reinforcement and piled up the end of the hose. In some cases it may protrude from the end of the hose fitting.

**Cause:** The probable cause is high vacuum or the wrong hose for vacuum service. No vacuum is recommended for double wire braid, 4 and 6 spiral wire hose unless some sort of internal coil support is used. Even though a hose is rated for vacuum service, if it is kinked, flattened out or bent too sharply this type of failure may occur.

**9. Symptom:** Hose has burst about six to eight inches away from the end fitting. The wire braid is rusted. There are no cuts or abrasions of the outer cover.

**Cause:** Improper assembly of the hose end fitting allowing moisture to enter around the edge of the fitting socket. The moisture will wick through the reinforcement. The heat generated by the system will drive it out around the fitting area but six to eight inches away it will be entrapped between the inner line and outer cover causing corrosion of the wire reinforcement.

**10. Symptom:** There are blisters in the cover of the hose. If one pricks the blisters, oil will be found in them.

**Cause:** A minute pin hole in the hose tube is allowing the high pressure oil to seep between it and the cover. Eventually it will form a blister wherever the cover adhesion is weakest. In the case of a screw together reusable fitting insufficient lubrication of the hose and fitting can cause this condition because the dry tube will adhere to the rotating nipple and tear enough to allow seepage. Faulty hose can also cause this condition.

**11. Symptom:** Blistering of the hose cover where a gaseous fluid is being used.



**Cause:** The high pressure gas is effusing through the hose tube, gathering under the cover and eventually forming a blister wherever the adhesion is weakest. Specially constructed hoses are available for high pressure gaseous applications. Your supplier can advise you on the proper hose to use in these cases.

**12. Symptom:** Fitting blew off of the end of the hose.

**Cause:** It may be that the wrong fitting has been put on the hose. Recheck manufacturer's specifications and part numbers. In the case of a crimped fitting the wrong machine setting may have been used resulting in over or under crimping. The socket of a screw together fitting for multiple wire braided hose may be worn beyond its tolerance. The swaging dies in a swaged hose assembly may be worn beyond the manufacturer's tolerances. The fitting may have been applied improperly to the hose. Check manufacturer's instructions. The hose may have been installed without leaving enough slack to compensate for the possible 4% shortening that may occur when the hose is pressurized. This will impose a great force on the fitting. The hose itself may be out of tolerance.

**13. Symptom:** The tube of the hose is badly deteriorated with evidences of extreme swelling. In some cases the hose tube may be partially "washed out."

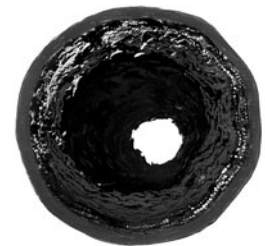

**Cause:** Indications are that the hose tube is not compatible with the agent being carried. Even though the agent is normally compatible, the addition of heat can be the catalyst that can cause inner liner deterioration. Consult your hose supplier for a compatibility list or present him with a sample of the fluid being conducted by the hose for analysis. Make sure that the operating temperatures both internal and external do not exceed recommendations.

**14. Symptom:** Hose has burst. The hose cover is badly deteriorated and the surface of the rubber is crazed.

## Analyzing failures

**Cause:** This could be simply old age. The crazed appearance is the effect of weathering and ozone over a period of time. Try to determine the age of the hose. Some manufacturers print or emboss the cure date on the outside of the hose. As an example, Aeroquip hose would show "4Q01" which would mean that the hose was manufactured during the fourth quarter (October, November or December) of 2001.

**15. Symptom:** Hose is leaking at the fitting because of a crack in the metal tube adjacent to the braze on a split flange head.

**Cause:** Because the crack is adjacent to the braze and not in the braze this is a stress failure brought on by a hose that is trying to shorten under pressure and has insufficient slack in it to do so. We have cured dozens of these problems by lengthening the hose assembly or changing the routing to relieve the forces on the fitting.

**16. Symptom:** A spiral reinforced hose has burst and literally split open with the wire exploded out and badly entangled.



**Cause:** The hose is too short to accommodate the change in length occurring while it is pressured.

**17. Symptom:** Hose is badly flattened out in the burst area. The tube is very hard down stream of the burst but appears normal up stream of the burst.



**Cause:** The hose has been kinked either by bending it too sharply or by squashing it in some way so that a major restriction was created. As the velocity of the fluid increases through the restriction the pressure decreases to the vaporization point of the fluid being conveyed. This is commonly called cavitation, and causes heat and rapid oxidation to take place which hardens the tube of the hose down stream of the restriction.

**18. Symptom:** Hose has not burst but it is leaking profusely. A bisection of the hose reveals that the tube has been gouged through to the wire braid for a distance of approximately two inches.

**Cause:** This failure would indicate that erosion of the hose tube has taken place. A high velocity needle like fluid stream being emitted from an orifice and impinging at a single point on the hose tube will hydraulically remove a section of it. Be sure that the hose is not bent close to a port that is orificed. In some cases where high velocities are encountered particles in the fluid can cause considerable erosion in bent sections of the hose assembly.

**19. Symptom:** The hose fitting has been pulled out of the hose. The hose has been considerably stretched out in length. This may not be a high pressure application.

**Cause:** Insufficient support of the hose. It is very necessary to support very long lengths of hose, especially if they are vertical. The weight of the hose along with the weight of the fluid inside the hose in these cases is being imposed on the hose fitting. This force can be transmitted to a wire rope or chain by clamping the hose to it much like the utilities support bundles of wire from pole to pole. Be sure to leave sufficient slack in the hose between clamps to make up for the possible 4% shortening that could take place when the hose is pressurized.

**20. Symptom:** The hose has not burst but it is leaking profusely. An examination of the bisected hose reveals that the tube has burst inwardly.

**Cause:** This type of failure is commonly referred to as hose tube blow down. It is usually associated with very low viscosity fluids such as air, nitrogen, freon and other gases. What happens is that under high pressure conditions the gases will effuse into the pores of the hose tube charging them up like miniature accumulators. If the pressure is very suddenly reduced to zero the entrapped gases literally explode out of the tube often tearing holes in it. In some hose constructions a second hose tube made from a plastic such as nylon, is inserted into the hose.

A small leak will allow the gaseous fluid to seep between the two inner liners and when pressure is reduced to zero the innermost liner will collapse because the entrapped pressure around its inner diameter.

**21. Symptom:** PTFE hose assembly has collapsed internally in one or more places.

**Cause:** One of the most common causes for this is improper handling of the PTFE assembly. PTFE is a thermoplastic material which is not rubber-like. When bent sharply it simply collapses. This type of collapse is localized in one area and is radical. When the PTFE tube is folded longitudinally in one or more places this could be the result of heat (which softens the hose) along with vacuum conditions inside of it. Because of the additional tension of the wire braid, reinforcement inherent with this type of hose, there is always a radial tension on the tube trying to push it in. Rapid cycling from a very hot agent in the hose to a very cold agent in the hose can produce the same type of failure. Danfoss Aeroquip offers an internal support coil that will eliminate this problem.

**22. Symptom:** A PTFE hose assembly has developed a pin hole leak or several pin hole leaks.

**Cause:** This situation occurs when a petroleum based fluid, with low viscosity, is flowing at high velocity. This condition can generate high voltage use to static electricity. The high voltage is seeking a ground connection and the only ground connection available is the braided stainless steel reinforcement. This causes an electric arc, which penetrates through the PTFE tube as it travels to the reinforcement. Specially constructed PTFE tubes are available that have enough carbon black in them so as to be conductive. They will "drain off" the static electricity and preclude this problem.

## Fluid connectors identification

### Fluid connectors identification

Measuring Tools: A seat angle gauge, thread pitch gauge and an I.D./O.D. caliper are necessary to make accurate measurements of commonly used connectors. Danfoss offers a unique new caliper than offers the capabilities of both a caliper and a seat angle gauge in one unit.



#### FT1341

#### Identification Tool Kit

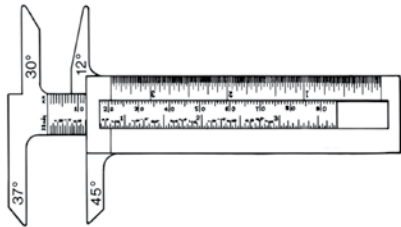

I.D./O.D. Angle gauge caliper

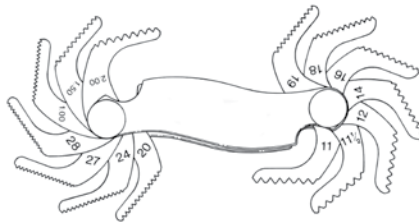

Thread pitch gauge

### How to measure threads

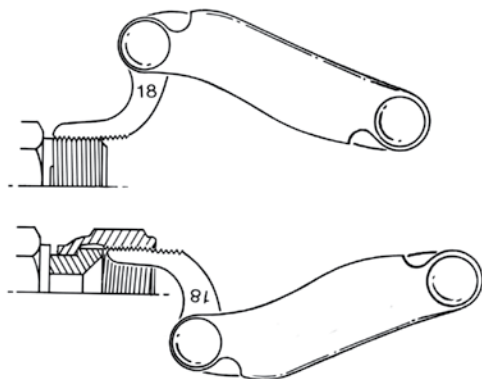

Use a thread pitch gauge to determine the number of threads per inch or the distance between threads in metric connections. Place the gauge on the threads until the fit is snug. Match the measurement to the charts.

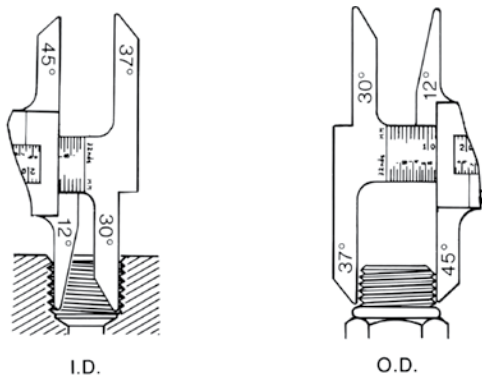

I.D.

O.D.

### How to measure sealing surface angles

**Female** connections are usually measured by inserting the gauge into the connection and placing it on the sealing surface. If the centerlines of the connection and gauge are parallel, the correct angle has been determined.

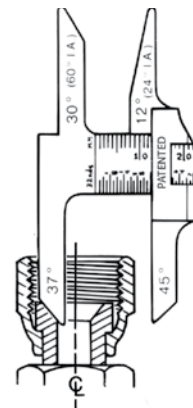

**Male flare type** connectors are usually measured by placing the gauge on the sealing surface. If the centerlines of the connection and gauge are parallel, the correct angle has been determined.

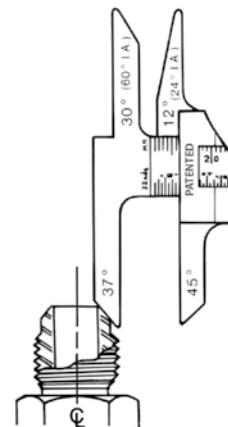

Measure the thread diameter with an I.D./O.D. caliper as shown. Match the measurements to the charts.



## Thread size chart

The following chart is intended as a quick reference guide for thread size by dash size.

Tube O.D. "R" Dim. l.Rh.*	Tube O.D. "R" Dim. s.Rh.†	Metric thread size	Male thread O.D.		Female thread I.D.	
			mm	in	mm	in
6.0 (0.24)	-	M12 x 1.5	12.0	0.47	10.5	0.41
8.0 (0.32)	6.0 (0.24)	M14 x 1.5	14.0	0.55	12.5	0.49
10.0 (0.39)	8.0 (0.32)	M16 x 1.5	16.0	0.63	14.5	0.57
12.0 (0.47)	10.0 (0.39)	M18 x 1.5	18.0	0.71	16.5	0.65
-	12.0 (0.47)	M20 x 1.5	20.0	0.78	18.5	0.73
15.0 (0.59)	14.0 (0.55)	M22 x 1.5	22.0	0.87	20.5	0.81
-	16.0 (0.63)	M24 x 1.5	24.0	0.94	22.5	0.89
18.0 (0.71)	-	M26 x 1.5	26.0	1.02	24.5	0.96
22.0 (0.87)	20.0 (0.78)	M30 x 2.0	30.0	1.18	28.0	1.11
28.0 (1.10)	25.0 (.98)	M36 x 2.0	36.0	1.41	34.0	1.34
-	30.0 (1.18)	M42 x 2.0	42.0	1.65	40.0	1.57
35.0 (1.38)	-	M45 x 2.0	45.0	1.70	43.0	1.70
42.0 (1.65)	38.0 (1.50)	M52 x 2.0	52.0	2.04	50.0	1.97

\*l.Rh = Light  
†s.Rh. = Heavy

## Through hole dimensions

All dimensions are nominal. In jump size bodies, the minimum through hole dimensions will correspond to the smallest dash size.

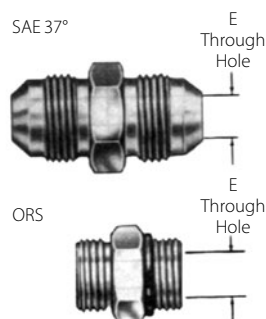

Dash size	E through hole			
	SAE 37°		ORS	
	mm	in	mm	in
-03	3.0	0.12	-	-
-04	4.3	0.17	4.3	0.17
-05	5.8	0.23	-	-
-06	7.6	0.30	6.6	0.26
-08	9.9	0.39	9.7	0.38
-10	12.2	0.48	12.2	0.48
-12	15.5	0.61	15.5	0.61
-16	21.3	0.84	20.6	0.81
-20	25.8	1.08	26.7	1.05
-24	33.3	1.31	33.3	1.31
-32	45.2	1.78	-	-

## Proper tube installation

### Proper tube installation

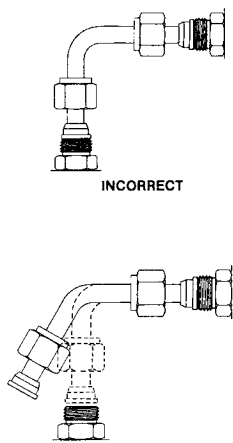

Figure 1

When compared to rigid pipe, hydraulic tubing offers the following advantages:

1. Size for size, tubing is lighter in weight, easier to handle and can be bent more easily than iron pipe.
2. Bent tubing reduces pressure drop and turbulence in the system because it eliminates sudden change in the direction of the fluid flow.
3. Hydraulic tubing reduces the number of connections required, thus reducing material and labor costs.
4. Fewer joints means lower costs and fewer points of potential leakage.
5. The use of tube fittings makes every joint a union which permits easier, faster maintenance and repair work.
6. The ORS-TF Tube Fitting eliminates the need for threading, brazing or welding.

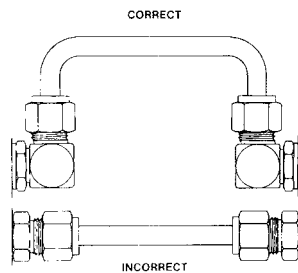

Figure 2

#### Tube bending

To reduce the number of fittings in a tube assembly, bend the tubing whenever possible.

Steel tubing can be bent in many sizes by using a hand bender designed for steel tubing. For production quantities, or for larger sizes, a power bending tool is generally used.

Contact Danfoss for additional tube bending information.

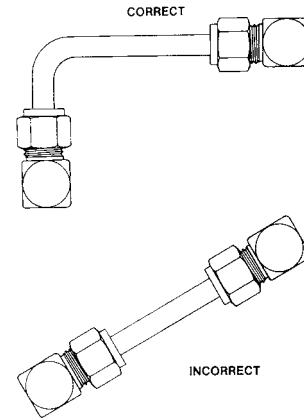

Figure 3

#### Tube routing and installation

Tubing manufacturers will advise the correct radii for various types and wall thicknesses of tubing. Kinks, flattened bends, wrinkles and tube breakage can be avoided by the use of proper tube bending equipment.

Avoid straight line connections whenever possible, especially in short runs.

Fluid conveying systems (see figures 2, 3 and 4) should be designed to follow the contour of the equipment. They are easier to install and present a neater appearance. Long runs should be supported by brackets or clamps. All heavy systems components should be bolted or clamped to eliminate tubing fatigue.

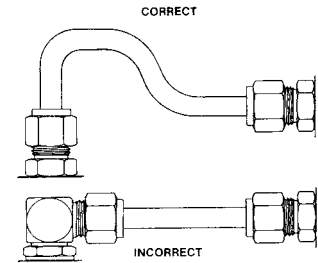

Figure 4

Inspect the tubing to see that it conforms to the required specifications before installation.

Tubes should align with the center line of the fittings, without distortion or tension. Tubing should not be sprung into position (see figure 1) to be assembled to the fitting. If this occurs the tubing has not been properly fabricated, and when installed and connected, places the tubing under stress.

## How to measure non-threaded connections

### Four bolt flange

First measure the port hole diameter using the caliper. Next, measure the longest bolt hole spacing from center- to-center or measure the flange head diameter.

### Staplok

Measure the male diameter with the O.D. portion of the caliper. Measure the female half by inserting the I.D. portion of the caliper into the through hole.

### Dash numbers

Most fluid piping system sizes in the United States are measured by dash numbers. These are universally used abbreviations for the size of the component expressed as the numerator of the fraction

with the denominator always being 16. For example, a -04 port is 4/16 or 1/4-inch. Dash numbers are usually nominal (in name only) and are abbreviations that make ordering of components easier.

## American connections

### NPTF (National pipe tapered fuel)

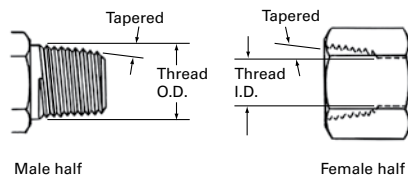

This connection is still widely used in fluid power systems, even though it is not recommended by the National Fluid Power Association (NFPA) for use in hydraulic applications. The thread

is tapered and the seal takes place by deformation of the threads.

### NPSM (National pipe straight mechanical)

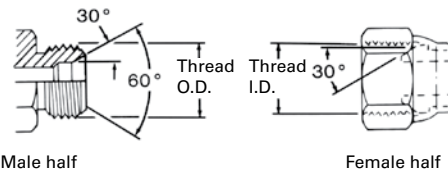

This connection is sometimes used in fluid power systems. The female half has a straight thread and an inverted 30° seat. The male half of the connection has a straight thread and a 30° internal chamfer. The seal takes place by compression of the 30° seat on

the chamfer. The threads hold the connection mechanically.

A properly chamfered NPTF male will also seal with the NPSM female.

NPTF threads		Measure thread diameter and subtract 1/4-inch to find the nominal pipe size.				
Inch size	Dash size.	Nominal thread size	Male thread O.D. inch		Female thread I.D. inch	
			Frac.	Dec.	Frac.	Dec.
1/8	02	1/8-27	13/32	0.41	3/8	0.38
1/4	04	1/4-18	17/32	0.54	1/2	0.49
3/8	06	3/8-18	11/16	0.68	5/8	0.63
1/2	08	1/2-14	27/32	0.84	25/32	0.77
3/4	12	3/4-14	1 1/16	1.05	1	0.98
1	16	1-11 1/2	1 5/16	1.32	1 1/4	1.24
1 1/4	20	1 1/4-11 1/2	1 21/32	1.66	1 19/32	0.58
1 1/2	24	1 1/2-11 1/2	1 29/32	1.90	1 13/16	1.82
2	32	2-11 1/2	2 3/8	2.38	2 5/16	2.30

NPSM threads						
Inch size	Dash size.	Nominal thread size	Male thread O.D. inch		Female thread I.D. inch	
			Frac.	Dec.	Frac.	Dec.
1/8	02	1/8-27	13/32	0.41	3/8	0.38
1/4	04	1/4-18	17/32	0.54	1/2	0.49
3/8	06	3/8-18	11/16	0.68	5/8	0.63
1/2	08	1/2-14	27/32	0.84	25/32	0.77
3/4	12	3/4-14	1 1/16	1.05	1	0.98
1	16	1-11 1/2	1 5/16	1.32	1 1/4	1.24
1 1/4	20	1 1/4-11 1/2	1 21/32	1.66	1 19/32	0.58
1 1/2	24	1 1/2-11 1/2	1 29/32	1.90	1 13/16	1.82
2	32	2-11 1/2	2 3/8	2.38	2 5/16	2.30



## American connections

## American connections

## SAE J1926 straight thread O-Ring boss (ORB)

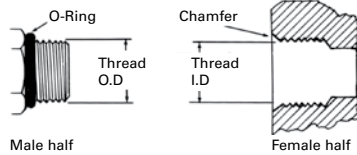

This port connection is recommended by the NFPA for optimum leakage control in medium and high pressure hydraulic systems. The male connector has a straight thread and an O-Ring. The female port has a straight thread, a machined

surface (minimum spotface) and a chamfer to accept the O-Ring. The seal takes place by compressing the O-Ring into the chamfer. The threads hold the connection mechanically.

## SAE J514 37° hydraulic

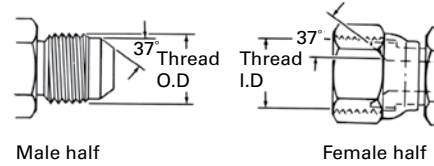

This connection is very common in fluid power systems. Both the male and female halves of the connections have 37° seats. The seal takes place by establishing a line contact between the male flare and the female cone seat. The threads

hold the connection mechanically.

**Caution:** In the -02, -03, -04, -05, -08 and -10 sizes, the threads of the SAE 45° flare and the SAE 37° flare are the same. However, the sealing surface angles are not the same.

Inch size	Dash size.	Nominal thread size	Male thread O.D. inch		Female thread I.D. inch	
			Fract.	Dec.	Fract.	Dec.
1/8	02	5/16-24	5/16	0.31	9/32	0.27
3/16	03	3/8-24	3/8	0.38	11/32	0.34
1/4	04	7/16-20	7/16	0.44	13/32	0.39
5/16	05	1/2-20	1/2	0.50	15/32	0.45
3/8	06	9/16-18	9/16	0.56	17/32	0.51
1/2	08	3/4-16	3/4	0.75	3/4	0.69
5/8	10	7/8-14	7/8	0.88	13/16	0.81
3/4	12	1 1/16-12	1 1/16	1.06	1	0.98
7/8	14	1 3/16-12	1 3/16	1.19	1 1/8	1.13
1	16	1 5/16-12	1 5/16	1.31	1 1/4	1.23
1-1/4	20	1 5/8-12	1 5/8	1.63	1 9/16	1.54
1-1/2	24	1 7/8-12	1 7/8	1.88	1 13/16	1.79
2	32	2 1/2-12	2 1/2	2.50	2 7/16	2.42

Inch size	Dash size.	Nominal thread size	Male thread O.D. inch		Female thread I.D. inch	
			Fract.	Dec.	Fract.	Dec.
1/8	02	5/16-24	5/16	0.31	9/32	0.27
3/16	03	3/8-24	3/8	0.38	11/32	0.34
1/4	04	7/16-20	7/16	0.44	13/32	0.39
5/16	05	1/2-20	1/2	0.50	15/32	0.45
3/8	06	9/16-18	9/16	0.56	17/32	0.51
1/2	08	3/4-16	3/4	0.75	3/4	0.69
5/8	10	7/8-14	7/8	0.88	13/16	0.81
3/4	12	1 1/16-12	1 1/16	1.06	1	0.98
7/8	14	1 3/16-12	1 3/16	1.19	1 1/8	1.13
1	16	1 5/16-12	1 5/16	1.31	1 1/4	1.23
1-1/4	20	1 5/8-12	1 5/8	1.63	1 9/16	1.54
1-1/2	24	1 7/8-12	1 7/8	1.88	1 13/16	1.79
2	32	2 1/2-12	2 1/2	2.50	2 7/16	2.42

## ORS SAE J1453 O-Ring face seal

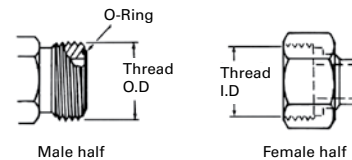

This connection offers the very best leakage control available today. The male connector has a straight thread and an O-Ring in the face. The female has a straight thread and a machined flat face.

The seal takes place by compressing the O-Ring onto the flat face of the female, similar to the split flange type fitting. The threads hold the connection mechanically.

Inch size	Dash size.	Nominal thread size	Male thread O.D. inch		Female thread I.D. inch	
			Fraction	Decimal	Fraction	Decimal
1/4	04	9/16-18	9/16	0.56	17/32	0.51
3/8	06	11/16-16	11/16	0.69	5/8	0.63
1/2	08	13/16-16	13/16	0.82	3/4	0.75
5/8	10	1-14	1	1.00	15/16	0.93
3/4	12	1 3/16-12	1 3/16	1.19	1 1/8	1.11
1	16	1 7/16-12	1 7/16	1.44	1 3/8	1.36
1-1/4	20	1 11/16-12	1 11/16	1.69	1 5/8	1.61
1-1/2	24	2-12	2	2.00	1 15/16	1.92

## American connections

### SAE J512 inverted

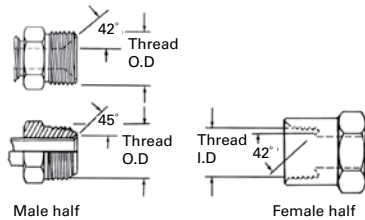

This connection is frequently used in automotive systems. The male connector can either be a 45° flare in the tube fitting form or a 42° seat in the machined adapter form.

The female has a straight thread

with a 42° inverted flare. The seal takes place on the flared surfaces. The threads hold the connection mechanically.

Inch size	Dash size	Nominal thread size	Male thread O.D. inch		Female thread I.D. inch	
			Fract.	Dec.	Fract.	Dec.
1/8	02	5/16-24	5/16	0.32	9/32	0.28
3/16	03	3/8-24	3/8	0.38	11/32	0.34
1/4	04	7/16-24	7/16	0.44	13/32	0.40
5/16	05	1/2-20	1/2	0.50	15/32	0.45
3/8	06	5/8-18	5/8	0.63	9/16	0.57
7/16	07	11/16-18	11/16	0.69	5/8	0.63
1/2	08	3/4-18	3/4	0.75	23/32	0.70
5/8	10	7/8-18	7/8	0.88	13/16	0.82
3/4	12	1 1/16-16	1 1/16	1.06	1	1.00

### SAE J512 45°

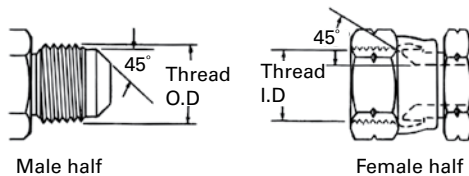

This connection is commonly used in refrigeration, automotive and truck piping systems. The connector is frequently made of brass. Both the male and female connectors have 45° seats. The seal takes place between the male flare the female

cone seat. The threads hold the connection mechanically.

**Caution:** In the -02, -03, -04, -05, -08 and -10 sizes, the threads of the SAE 45° flare and the SAE 37° flare are the same. However, the sealing surface angles are not the same.

Inch size	Dash size	Nominal thread size	Male thread O.D. inch		Female thread I.D. inch	
			Fract.	Dec.	Fract.	Dec.
1/8	02	5/16-24	5/16	0.31	9/32	0.27
3/16	03	3/8-24	3/8	0.38	11/32	0.34
1/4	04	7/16-20	7/16	0.44	13/32	0.39
5/16	05	1/2-20	1/2	0.50	15/32	0.45
3/8	06	5/8-18	5/8	0.63	9/16	0.57
1/2	08	3/4-16	3/4	0.75	11/16	0.69
5/8	10	7/8-14	7/8	0.88	13/16	0.81
3/4	12	1 1/16-14	1 1/16	1.06	1	0.99
7/8	14	1 1/4-12	1 1/4	1.25	1 5/32	1.16
1	16	1 3/8-12	1 3/8	1.38	1 9/32	1.29

### Staplok (SAE J1467)

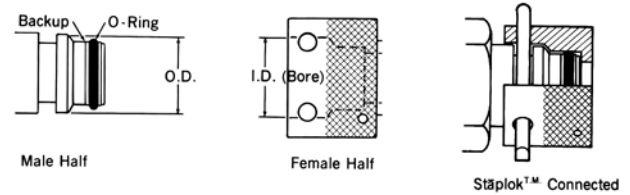

This is a radial O-Ring seal connection developed in Germany and commonly used for hydraulic application in underground mines. The male contains an exterior O-Ring and backup ring, plus a groove to accept the "staple". The female has a smooth bore

with two holes for the staple. A "U" shaped retaining clip or staple is inserted through the two holes, passing through the groove in the male to lock the connection together. The seal takes place by contact between the O-Ring in the male and the smooth bore of the female.

Inch size	Dash size	Nominal thread size	Male thread O.D. inch		Female thread I.D. inch	
			Fraction	Decimal	Fraction	Decimal
1/4	04	-	9/32	0.586	1 9/32	0.597
3/8	06	-	25/32	0.783	51/64	0.794
1/2	08	-	15/16	0.940	61/64	0.951
3/4	12	-	1 9/64	1.137	1 9/64	1.148
1	16	-	1 17/32	1.529	1 35/64	1.540
1-1/4	20	-	1 13/16	1.806	1 13/16	1.817
1-1/2	24	-	2 5/32	2.163	2 11/64	2.174
2	32	-	2 33/64	2.517	2 17/32	2.528

## American connections

## American connections and ISO connections

## American connections

## How to measure

Four Bolt Flange—First measure the port hole diameter using the caliper.

Next, measure the longest bolt hole spacing from center-to-center (Dimension "A") or measure the flanged head diameter.

## SAE J518 4-Bolt Flange\*

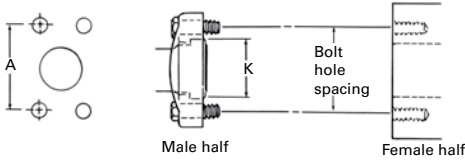

This connection is commonly used in fluid power systems. There are two pressure ratings. Code 61 is referred to as the "standard" series and Code 62 is the "6000 psi" series. The design concept for both series is the same, but the bolt hole spacing and flanged head diameters are larger for the higher pressure, Code 62 connection. The female (port) is an unthreaded hole with four bolt holes in a rectangular pattern around the port. The male consists of a flanged head,

grooved for an O-Ring, and either a captive flange or split flange halves with bolt holes to match the port. The seal takes place on the O-Ring, which is compressed between the flanged head and the flat surface surrounding the port. The threaded bolts hold the connection together.

NOTE: \* SAE J518, JIS B 8363, ISO/DIS 6162 and DIN 20066 are interchangeable, except for bolt sizes.

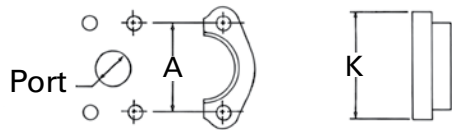

Inch Size (dash size)	Port hole I.D. inch (dash size)	Bolt dimension inch		Bolt hole spacing "A" inch (dec)		Flanged head dia. "K" inch (dec)	
		Cd. 61	Cd. 62	Cd. 61	Cd. 62	Cd. 61	Cd. 62
1/2 (08)	1/2 (0.50)	5/16-18x1 1/4	5/16-18x1 1/4	1 1/2 (1.50)	1 19/32 (1.59)	1 3/16 (1.19)	1 1/4 (1.25)
3/4 (12)	3/4 (0.75)	3/8-16x1 1/4	3/8-16x1 1/2	1 7/8 (1.88)	2.00 (2.00)	1 1/2 (1.50)	1 5/8 (1.63)
1 (16)	1.00 (1.00)	3/8-16x1 1/4	7/16-14x1 3/4	2 1/16 (2.06)	2 1/4 (2.25)	1 3/4 (1.75)	1 7/8 (1.88)
1 1/4 (20)	1 1/4 (1.25)	7/16-14x1 1/2	1/2-13x1 3/4	2 5/16 (2.31)	2 5/8 (2.63)	2.00 (2.00)	2 1/8 (2.13)
1 1/2 (24)	1 1/2 (1.50)	1/2-13x1 1/2	5/8-11x2 1/4	2 3/4 (2.75)	3 1/8 (3.12)	2 3/8 (2.38)	2 1/2 (2.50)
2 (32)	2.00 (2.00)	1/2-13x1 1/2	3/4-10x2 3/4	3 1/16 (3.06)	3 13/16 (3.81)	2 13/16 (2.81)	3 1/8 (3.12)

## ISO connections

## ISO/DIS 6162 4-bolt flange\*

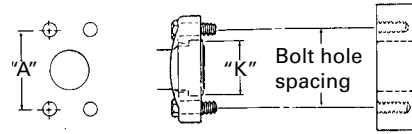

## Male half

This connection is commonly used in fluid power systems. There are two pressure ratings. PN 35/350 bar (Code 61) is the "standard" series and PN 415 bar (Code 62) is the high pressure series. The design concept for both series is the same, but the bolt hole spacing and flanged head diameters are larger for the higher pressure, PN 415 bar connection. Both metric and inches bolts are used. The port will have an "M" stamped on it if metric bolts are required.

## Female half

The female (port) is an unthreaded hole with four bolt holes in a rectangular pattern around the port. The male consists of a flanged head, grooved for an O-Ring, and either a captive flange or split flange halves with bolt holes to match the port. The seal takes place on the O-Ring, which is compressed between the flanged head and the flat surface surrounding the port. The threaded bolts hold the connection together.

\* ISO/DIS 6162, DIN 20066, JIS B 8363 and SAE J518 are interchangeable, except for bolt sizes.

Size	Port hole	Bolt dimensions spacing		Bolt hole "A"	
		ISO 6162-1 Bar (Cd.61)	ISO 6162-2 Bar (Cd.62)	ISO 6162-1 Bar (Cd.61)	ISO 6162-2 Bar (Cd.62)
		mm (in)	mm (in)	mm (in)	mm (in)
13 (1/2) (08)	12,7 (0.50)	M8 x 1.25 x 30 (5/16-18 x 1-1/4)	M8 x 1.25 x 30 (5/16-18 x 1-1/4)	38.1 (1.50)	40.5 (1.57)
19 (3/4) (12)	19,1 (0.75)	M10 x 1.5 x 35 (3/8-16 x 1-1/4)	M10 x 1.5 x 40 (3/8-16 x 1-1/2)	47.6 (1.88)	50.8 (2.00)
25 (1) (16)	25,4 (1.00)	M10 x 1.5 x 35 (3/8-16 x 1-1/4)	M12 x 1.75 x 45 (7/16-14 x 1-3/4)	52.4 (2.06)	57.2 (2.25)
32 (1-1/4) (20)	31,8 (1.25)	M10 x 1.5 x 40 (7/16-14 x 1-1/2)	M14 x 2 x 50 (1/2-13 x 1-3/4)	58.7 (2.31)	66.7 (2.63)
38 (1-1/2) (24)	38,1 (1.50)	M12 x 1.75 x 40 (1/2-13 x 1-1/2)	M16 x 2 x 55 (5/8-11 x 2-1/4)	69.9 (2.75)	79.4 (3.13)
51 (2) (32)	50,8 (2.00)	M12 x 1.75 x 40 (1/2-13 x 1-1/2)	M20 x 2.5 x 70 (3/4-10 x 2-3/4)	77.8 (3.06)	96.8 (3.81)

Inch size	Flanged head dia. "K"			
	ISO 6162-1 Bar (Cd.61)		ISO 6162-2 Bar (Cd.62)	
	mm	in	mm	in
1/2	30.2	1.19	31.8	1.25
3/4	38.1	1.50	41.3	1.63
1	44.5	1.75	47.6	1.88
1-1/4	50.8	2.00	54.0	2.13
1-1/2	60.3	2.38	63.5	2.50
2	71.4	2.81	79.4	3.13

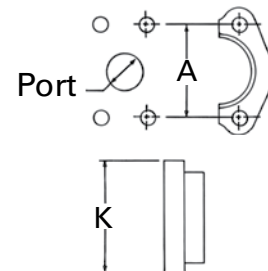

## Metric (German) connections

### Metric (German) connections

#### DIN 7631 series

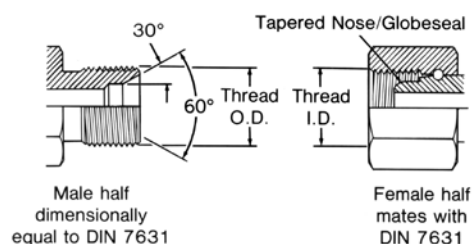

This connection is frequently used in hydraulic systems. The male has a straight metric thread and a 60° (included angle) recessed cone. The female has a straight thread and a tapered Nose/Globeseal seat. The seal takes place by contact between the cone

of the male and the nose of the tapered Nose/Globeseal flareless swivel.

The threads hold the connection mechanically.

Use with pipe/tube O.D.		Metric thread size	Male thread O.D.		Female thread I.D.	
mm	in		mm	in	mm	in
6.0	0.24	M12 x 1.5	12.0	0.47	10.5	0.41
8.0	0.32	M14 x 1.5	14.0	0.55	12.5	0.49
10.0	0.39	M16 x 1.5	16.0	0.63	14.5	0.57
12.0	0.47	M18 x 1.5	18.0	0.71	16.5	0.65
15.0	0.59	M22 x 1.5	22.0	0.87	20.5	0.81
18.0	0.71	M26 x 1.5	26.0	1.02	24.5	0.96
22.0	0.87	M30 x 1.5	30.0	1.18	28.5	1.12
28.0	1.10	M38 x 1.5	38.0	1.50	36.5	1.44
35.0	1.38	M45 x 1.5	45.0	1.77	43.5	1.71
42.0	1.65	M52 x 1.5	52.0	2.04	50.5	1.99

#### DIN 3902 series

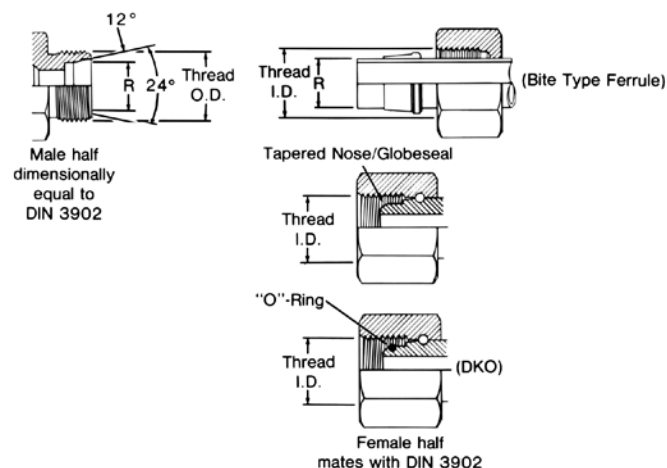

This connection style consists of a common male and three different female halves. The male has a straight metric thread, a 24° included angle and a recessed counterbore that matches the tube O.D. used with it. The female may be a tube, nut and

ferrule, a tapered nose/Globeseal flareless swivel or a tapered Nose/Globeseal flareless swivel with an O-Ring in the Nose (DKO type).

Tube O.D. "R" Dim. I.Rh.*		Tube O.D. "R" Dim. s.Rh.†		Metric thread Size	Male thread O.D.		Female thread I.D.	
mm	in.	mm	in		mm	in	mm	in
6.0	0.24	-	-	M12 x 1.5	12.0	0.47	10.5	0.41
8.0	0.32	6.0	0.24	M14 x 1.5	14.0	0.55	12.5	0.49
10.0	0.39	8.0	0.32	M16 x 1.5	16.0	0.63	14.5	0.57
12.0	0.47	10.0	0.39	M18 x 1.5	18.0	0.71	16.5	0.65
-	-	12.0	0.47	M20 x 1.5	20.0	0.78	18.5	0.73
15.0	0.59	14.0	0.55	M22 x 1.5	22.0	0.87	20.5	0.81
-	-	16.0	0.63	M24 x 1.5	24.0	0.94	22.5	0.89
18.0	0.71	-	-	M26 x 1.5	26.0	1.02	24.5	0.96
22.0	0.87	20.0	0.78	M30 x 2.0	30.0	1.18	28.0	1.11
28.0	1.10	25.0	0.98	M36 x 2.0	36.0	1.41	34.0	1.34
-	-	30.0	1.18	M42 x 2.0	42.0	1.65	40.0	1.57
35.0	1.38	-	-	M45 x 2.0	45.0	1.77	43.0	1.70
42.0	1.65	38.0	1.50	M52 x 2.0	52.0	2.04	50.0	1.97

\*I.Rh. is a light duty system.

†s.Rh. is a heavy duty system.

## German connections

### Metric (German) connections

#### Metric (German) connections

##### DIN 20066 4-bolt flange\*

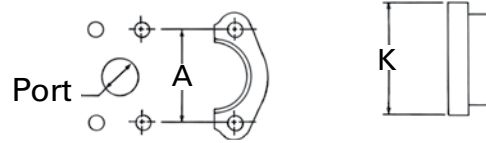
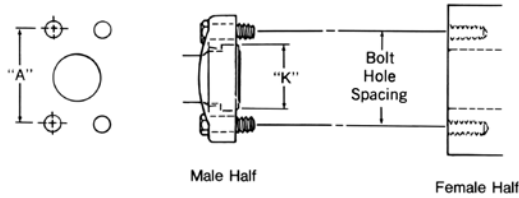

This connection is commonly used in fluid power systems. There are two pressure ratings. Form R (Code 61) is referred to as the “standard duty” series and Form S (Code 62) is the “heavy duty” series. The design concept for both series is the same, but the bolt hole spacing and flanged head diameters are larger for the higher pressure, Form S connection. Both metric and inch bolts are used. The female (port) is an unthreaded hole with four bolt holes in a rectangular pattern around the port. The male consists of a flanged head,

grooved for an O-Ring, and either a captive flange or split flange halves with bolt holes to match the port. The seal takes place on the O-Ring, which is compressed between the flanged head and the flat surface surrounding the port. The threaded bolts hold the connection together.

**NOTE:** \*DIN 20066, IS/DIS 6166, JIS B 8363 and SAE J518 are interchangeable, except for bolt sizes.

Inch size	Flanged head dia. “K”			
	Form R (Cd. 61)		Form S (Cd. 62)	
	mm	in	mm	in
1/2	30.2	1.19	31.8	1.25
3/4	38.1	1.50	41.3	1.63
1	44.5	1.75	47.6	1.88
1 1/4	50.8	2.00	54.0	2.13
1 1/2	60.3	2.38	63.5	2.50
2	71.4	2.81	79.4	3.13

Size mm (inch) (dash)	Port hole	Bolt dimensions		Bolt hole spacing	
		Form R (Cd. 61)	Form S (Cd. 62)	Form R (Cd. 61)	Form S (Cd. 62)
	mm (in)	-	-	mm (in)	mm (in)
12 (1/2) (08)	12,7 (0.50)	M8 x 1.25 x 30 5/16–18 x 1 1/4	M8 x 1.25 x 30 5/16–18 x 1 1/4	38.1 (1.50)	40.5 (1.57)
20 (3/4) (12)	19,1 (0.75)	M10 x 1.5 x 30 3/8–16 x 1 1/4	M10 x 1.5 x 40 3/8–16 x 1 1/2	47.6 (1.88)	50.8 (2.00)
25 (1) (16)	25,4 (1.00)	M10 x 1.5 x 35 3/8–16 x 1 1/4	M12 x 1.75 x 45 7/16–14 x 1 3/4	52.4 (2.06)	57.2 (2.25)
32 (1-1/4) (20)	31,7 (1.25)	M10 x 1.75 x 40 7/16–14 x 1 1/2	M14 x 2 x 45 1/2–13 x 1 3/4	58.7 (2.31)	66.7 (2.63)
40 (1-1/2) (24)	38,0 (1.50)	M12 x 1.75 x 40 1/2–13 x 1 1/2	M16 x 2 x 55 5/8–11 x 2 1/4	69.9 (2.75)	79.4 (3.13)
50 (2) (32)	50,8 (2.00)	M12 x 1.75 x 40 1/2–13 x 1 1/2	M20 x 2.5 x 70 3/4–10 x 2 3/4	77.8 (3.06)	96.8 (3.81)

## Metric (German) connections

### Metric (German) connections

#### DIN 3852 Male connectors and female ports

DIN 3852 metric threads				
Metric thread	Male thread O.D. "A"		Female thread I.D. "B"	
	mm	in	mm	(in)
M12 x 1.5	12.0	0.47	10.5	0.41
M14 x 1.5	14.0	0.55	12.5	0.49
M16 x 1.5	16.0	0.63	14.5	0.57
M18 x 1.5	18.0	0.71	16.5	0.65
M20 x 1.5	20.0	0.78	18.5	0.73
M22 x 1.5	22.0	0.87	20.5	0.81
M24 x 1.5	24.0	0.94	22.5	0.89
M26 x 1.5	26.0	1.02	24.5	0.96
M27 x 2.0	27.0	1.06	25.0	0.98
M30 x 1.5	30.0	1.18	28.5	1.12
M30 x 2.0	30.0	1.18	28.0	1.10
M33 x 2.0	33.0	1.30	31.0	1.22
M36 x 1.5	36.0	1.41	34.5	1.36
M36 x 2.0	36.0	1.41	34.0	1.33
M38 x 1.5	38.0	1.49	36.5	1.43
M38 x 2.0	38.0	1.49	36.0	1.41
M42 x 1.5	42.0	1.65	40.5	1.60
M42 x 2.0	42.0	1.65	40.0	1.57
M45 x 1.5	45.0	1.77	43.5	1.71
M45 x 2.0	45.0	1.77	43.0	1.69
M48 x 1.5	48.0	1.89	46.5	1.83
M48 x 2.0	48.0	1.89	46.0	1.81
M52 x 1.5	52.0	2.04	50.5	1.89
M52 x 2.0	52.0	2.04	50.0	1.97

For DIN 3852 Whitworth pipe thread dimensions, see BSPT/BSPP dimensions. They are the same.

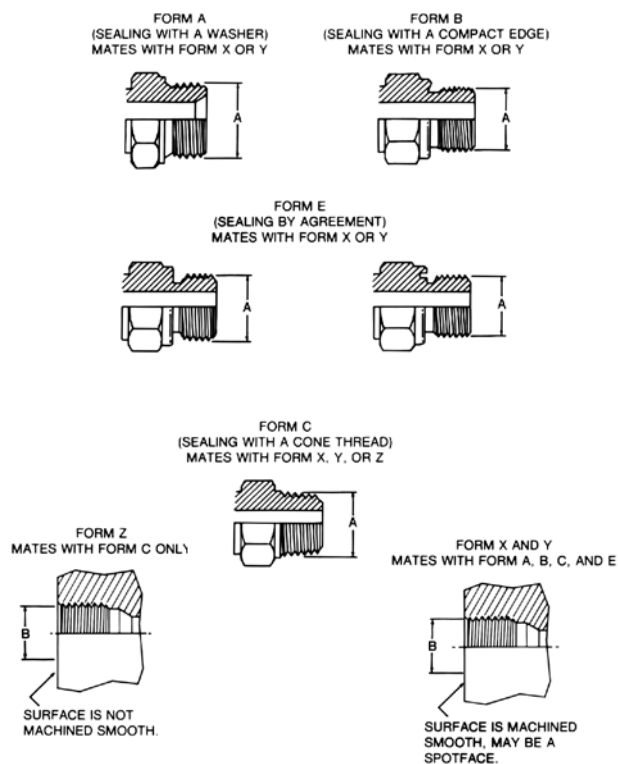

### How the seal works

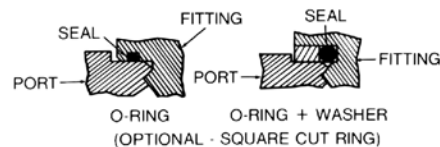
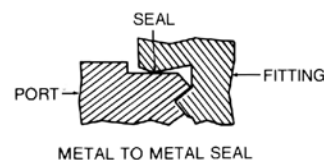
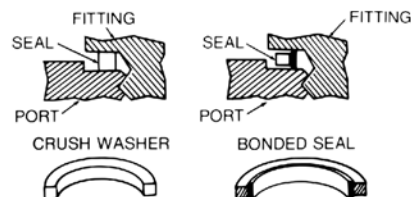

## French and British connections

### French & British connections

#### French connections

##### Millimetric and GAZ series

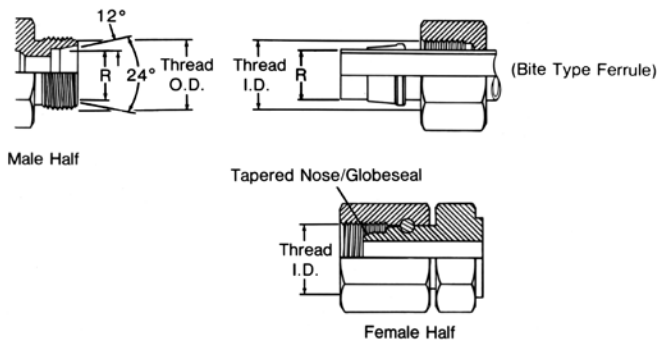

This connection consists of a common male and two different females. The millimetric series is used with whole number

metric O.D. tubing and the GAZ Series is used with fractional number metric O.D. pipe size tubing.

##### Millimetric and GAZ threads

Tubing O.D. "R" dim.		"Gaz" pipe O.D. R" dim.		Metric thread	Male Thread O.D. "A"		Female Thread I.D. "B"	
mm	in	mm	in		mm	in	mm	in
6.0	0.24	-	-	M12 x 1.5	12.0	0.47	11.0	0.43
8.0	0.32	-	-	M14 x 1.5	14.0	0.55	12.5	0.49
10.0	0.39	-	-	M16 x 1.5	16.0	0.63	14.5	0.57
12.0	0.47	-	-	M18 x 1.5	18.0	0.71	16.5	0.65
14.0	0.55	13.3	0.52	M20 x 1.5	20.0	0.78	18.5	0.73
15.0	0.59	-	-	M22 x 1.5	22.0	0.87	20.5	0.81
16.0	0.63	16.8	0.66	M24 x 1.5	24.0	0.94	22.5	0.89
18.0	0.71	-	-	M27 x 1.5	27.0	1.06	25.5	1.00
22.0	0.87	21.3	0.83	M30 x 1.5	30.0	1.18	28.5	1.12
25.0	0.98	-	-	M33 x 1.5	33.0	1.30	31.5	1.24
28.0	1.10	26.8	1.05	M36 x 1.5	36.0	1.41	34.5	1.36
30.0	1.18	-	-	M39 x 1.5	39.0	1.54	37.5	1.48
32.0	1.25	-	-	M42 x 1.5	42.0	1.65	40.5	1.60
35.0	1.38	33.5	1.32	M45 x 1.5	45.0	1.77	43.5	1.71
38.0	1.50	-	-	M48 x 1.5	48.0	1.89	46.5	1.83
40.0	1.57	42.3	1.66	M52 x 1.5	52.0	2.04	50.5	1.99
45.0	1.77	-	-	M54 x 2.0	54.0	2.12	52.0	2.05
-	-	48.3	1.90	M58 x 2.0	58.0	2.28	55.0	2.16

#### British connections

##### British standard pipe(BSP)

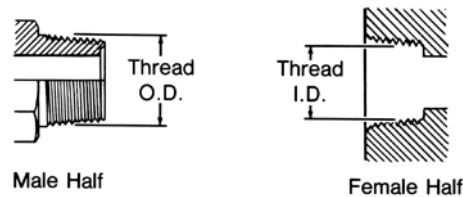

This BSPT (tapered) connection is similar to the NPT, except that the thread pitches are different in most sizes, and the thread form and O.D.s are close but not the

same. Sealing is accomplished by thread distortion. A thread sealant is recommended.

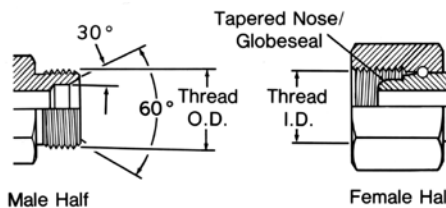

The BSP (parallel) male is similar to the NPSM male except the thread pitches are different in most sizes.

The female swivel BSPP has a tapered nose/Globeseal flareless swivel which seals on the cone seat of the male.

##### BSPT/BSPP threads

Inch size	Dash size	Nominal thread size	Male thread O.D. inch		Female thread I.D. inch	
			fraction	decimal	fraction	decimal
1/8	02	1/8-28	3/8	0.38	11/32	0.35
1/4	04	1/4-19	33/64	0.52	15/32	0.47
3/8	06	3/8-19	21/32	0.65	19/32	0.60
1/2	08	1/2-14	13/16	0.82	3/4	0.75
5/8	10	5/8-14	7/8	0.88	13/16	0.80
3/4	12	3/4-14	1 1/32	1.04	31/32	0.97
1	16	1-11	1 5/16	1.30	1 7/32	1.22
1 1/4	20	1 1/4-11	1 21/32	1.65	1 9/16	1.56
1 1/2	24	1 1/2-11	1 7/8	1.88	1 25/32	1.79
2	32	2-11	2 11/32	2.35	2 1/4	2.26

\*Frequently, the thread size is expressed as a fractional dimension preceded by the letter "G" or the letter "R". The "G" represents a parallel thread and the "R" indicates a tapered thread. For example, BSPP 3/8-19 may be expressed as G 3/8, and BSPT 3/8-19 may be expressed as R3/8.



## Japanese connections

### Japanese connections

#### JIS 30° male inverted seat, parallel pipe threads

(Threads per JIS B 0202)

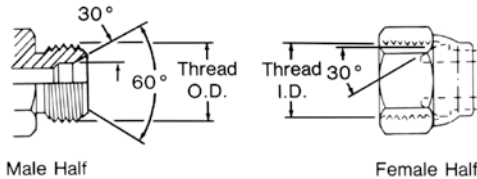

The JIS parallel is similar to the BSPP connection. The JIS parallel thread and the BSPP connection are interchangeable.

Inch size	Dash size	Nominal thread size (similar to bspp)	Male thread O.D.		Female thread O.D.	
			fract.	dec.	fract.	dec.
1/4	6 (04)	1/4-19	33/64	13.2	15/32	11.9
3/8	9 (06)	3/8-19	21/32	16.7	19/32	15.3
1/2	12 (08)	1/2-14	13/16	21.0	3/4	19.2
3/4	19 (12)	3/4-14	1 1/32	26.4	31/32	24.6
1	25 (16)	1-11	1 5/16	33.3	1 7/32	30.9
1 1/4	32 (20)	1 1/4-11	1 21/32	41.9	1 9/16	39.6
1 1/2	38 (24)	1 1/2-11	1 7/8	47.8	1 25/32	45.5
2	50 (32)	2-11	2 11/32	59.7	2 1/4	57.4

#### JIS 30° male inverted seat, parallel pipe threads

(Threads per JIS B 0207)

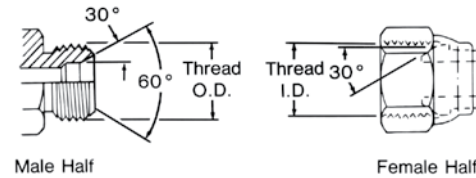

The JIS parallel (metric) is the same as the JIS parallel (PF),

except for the thread difference.

Inch size	Dash size equivalent	Thread size	Male thread O.D.		Female thread O.D.	
			fract.	dec.	fract.	dec.
6	04	M14 x 1.5	14	0.55	12.5	0.49
9	06	M18 x 1.5	18	0.71	16.5	0.65
12	08	M22 x 1.5	22	0.87	20.5	0.81
19	12	M30 x 1.5	30	1.18	28.5	1.12
25	16	M33 x 1.5	33	1.30	31.5	1.24
32	20	M42 x 1.5	42	1.65	40.5	1.60

#### JIS Tapered pipe (PT)

(Threads per JIS B 0203)

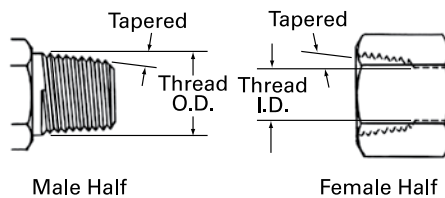

The JIS tapered thread is similar to the BSPT connection in design, appearance and dimensions. The JIS tapered thread and the BSPT connection are interchangeable.

Inch size	Dash size	Nominal thread size (similar to bspp)	Male thread O.D. inch		Female thread I.D. inch	
			fract.	dec.	fract.	dec.
1/4	6 (04)	1/4-19	33/64	13.2	15/32	11.9
3/8	9 (06)	3/8-19	21/32	16.7	19/32	15.3
1/2	12 (08)	1/2-14	13/16	21.0	3/4	19.2
3/4	19 (12)	3/4-14	1 1/32	26.4	31/32	24.6
1	25 (16)	1-11	1 5/16	33.3	1 7/32	30.9
1 1/4	32 (20)	1 1/4-11	1 21/32	41.9	1 9/16	39.6
1 1/2	38 (24)	1 1/2-11	1 7/8	47.8	1 25/32	45.5
2	50 (32)	2-11	2 11/32	59.7	2 1/4	57.4

#### JIS 30° female (cone) seat, parallel pipe threads (PT)

(Threads per JIS B 0202)

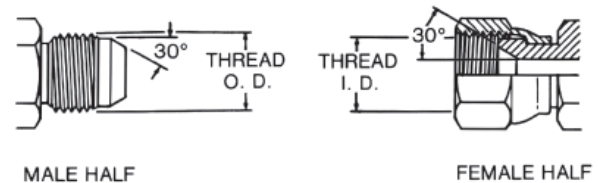

The Japanese JIS 30° flare is similar to the American SAE 37° flare connection in application as well as sealing principles. However, the

flare angle and dimensions are different. The threads are similar to BSPP.

Inch size	Dash size	Nominal thread size (similar to bspp)	Male thread O.D. inch		Female thread O.D. inch	
			fract.	dec.	fract.	dec.
1/4	6 (04)	1/4-19	33/64	13.2	15/32	11.9
3/8	9 (06)	3/8-19	21/32	16.7	19/32	15.3
1/2	12 (08)	1/2-14	13/16	21.0	3/4	19.2
3/4	19 (12)	3/4-14	1 1/32	26.4	31/32	24.6
1	25 (16)	1-11	1 5/16	33.3	1 7/32	30.9
1 1/4	32 (20)	1 1/4-11	1 21/32	41.9	1 9/16	39.6
1 1/2	38 (24)	1 1/2-11	1 7/8	47.8	1 25/32	45.5
2	50 (32)	2-11	2 11/32	59.7	2 1/4	57.4



## Japanese connections

## Japanese connections

## JIS B 8363 4-bolt flange\*

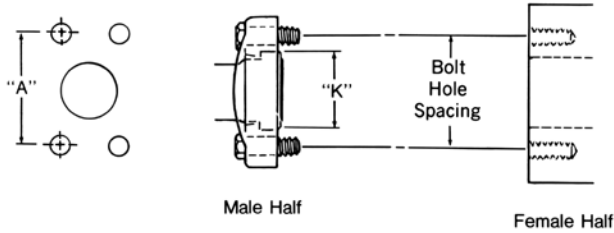

This connection is commonly used in fluid power systems. There are two pressure ratings. Type I (Code 61) is referred to as the "standard" series and Type II (Code 62) is the "6000 psi" series. The design concept for both series is the same, but the bolt hole spacing and flanged head diameters are larger for the higher pressure, Type II connection. Both metric and inch bolts are used. The female (port) is an unthreaded hole with four bolt holes in a rectangular

pattern around the port. The male consists of a flanged head, grooved for an O-Ring, and either a captive flange or split flange halves with bolt holes to match the port. The seal takes place on the O-Ring, which is compressed between the flanged head and the flat surface surrounding the port. The threaded bolts hold the connection together.

**NOTE:** \*JIS B 8363, ISO/DIS 6162, DIN 20066, and SAE J518 are interchangeable, except for bolt sizes.

Size	Port hole	Bolt dimensions		Bolt hole spacing "A"	
		Type I (Cd.61)	Type II (Cd. 62)	Type I (Cd. 61)	Type II (Cd. 62)
mm(in) (dash)	mm(in)	mm(in)	mm(in)	mm(in)	mm(in)
12 (1/2) (08)	12,7 (0.50)	M8 x 1.25 x 30 (5/16-18 x 1-1/4)	M8 x 1.25 x 30 (5/16-18 x 1-1/4)	38.1 (1.50)	40.5 (1.57)
19 (3/4) (12)	19,1 (0.75)	M10 x 1.5 x 30 (3/8-16 x 1-1/4)	M10 x 1.5 x 40 (3/8-16 x 1-1/2)	47.6 (1.88)	50.8 (2.00)
25 (1) (16)	25,4 (1.00)	M10 x 1.5 x 30 (3/8-16 x 1-1/4)	M12 x 1.75 x 45 (7/16-14 x 1-3/4)	52.8 (2.06)	57.2 (2.25)
32 (1-1/4) (20)	31,7 (1.25)	M10 x 1.5 x 40 (7/16-14 x 1-1/2)	M14 x 2 x 45 (1/2-13 x 1-3/4)	58.7 (2.31)	66.7 (2.63)
38 (1-1/2) (24)	38,0 (1.50)	M12 x 1.75 x 40 (1/2-13 x 1-1/2)	M16 x 2 x 55 (5/8-11 x 2-1/4)	69.9 (2.75)	79.4 (3.13)
50 (2) (32)	50,8 (2.00)	M12 x 1.75 x 40 (1/2-13 x 1-1/2)	M20 x 2.5 x 70 (3/4-10 x 2-3/4)	77.8 (3.06)	96.8 (3.81)

Inch size	Flanged head dia. "K"			
	Type I bar (Cd.61)		Type II bar (Cd. 62)	
	mm	in	mm	in
1/2	30,2	1.19	31,8	1.25
3/4	38,1	1.50	41,3	1.63
1	44,5	1.75	47,6	1.88
1 1/4	50,8	2.00	54,0	2.13
1 1/2	60,3	2.38	63,5	2.50
2	71,4	2.81	79,4	3.13

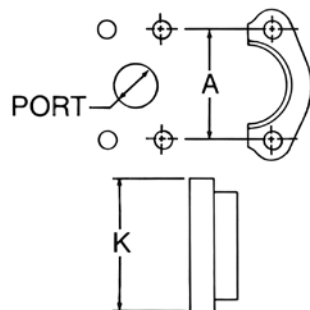

## JIS 210 Kgf/cm2 4-bolt square flange

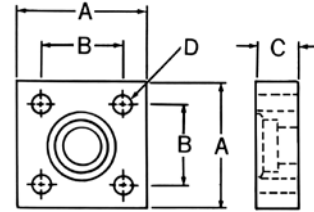

The JIS 4-bolt square flange connection is similar in concept to the SAE 4-bolt flange connection, except that the JIS bolt pattern is

square and the flange itself is different.

Size mm	Appx. inch size	Bolt size mm (bolt length for long (design))	Dim. "A" mm (inch)	Dim. "B" mm (inch)	Dim. "C" mm (inch)	Bolt hole dia "D" mm (inch)
12.0	1/2	M10 x 1.5 x 55 (80)	63.0 (2.48)	40.0 (1.57)	22.0 (0.87)	11.0 (0.43)
19.0	3/4	M10 x 1.5 x 55 (80)	68.0 (2.67)	45.0 (1.77)	22.0 (0.87)	11.0 (0.43)
25.0	1	M12 x 1.75 x 70 (100)	80.0 (3.15)	53.0 (2.09)	28.0 (1.10)	13.0 (0.51)
32.0	1 1/4	M12 x 1.75 x 70 (100)	90.0 (3.54)	63.0 (2.48)	28.0 (1.10)	13.0 (0.51)
38.0	1 1/2	M16 x 2.0 x 90 (130)	100.0 (3.94)	70.0 (2.76)	36.0 (1.42)	18.0 (0.71)
50.0	2	M16 x 2.0 x 90 (130)	112.0 (4.41)	80.0 (3.15)	36.0 (1.42)	18.0 (0.71)

## JIS 210 Kgf/cm2 O-Ring

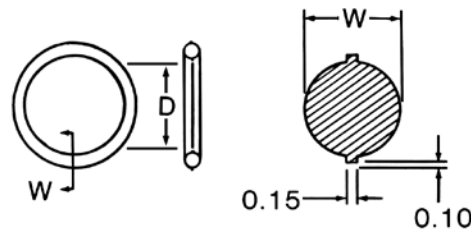

Nominal size mm	Dim. "D" mm	Dim. "W" mm
12.0	24.4 ± 0.15	3.1 ± 0.1
19.0	29.4 ± 0.15	3.1 ± 0.1
25.0	34.4 ± 0.15	3.1 ± 0.1
32.0	39.4 ± 0.15	3.1 ± 0.1
38.0	49.4 ± 0.15	3.1 ± 0.1
50.0	59.4 ± 0.15	3.1 ± 0.1

## O-Ring pilot thread sizes

This connection is common to air conditioning systems, both in vehicle and commercial applications. Both the male and female halves of the connections have a pilot, either long or short. The seal takes place by compressing an O-ring adjacent to the bead of the tube. The threads hold the connection together mechanically.

Inch size	Dash size	Male thread			Female thread		
		O.D. (inch) nominal thread	O.D. (inch) fraction	O.D. (inch) decimal	I.D. (inch) nominal thread	I.D. (inch) fraction	I.D. (inch) decimal
3/8	06	5/8 - 18	5/8	0.62	5/8 - 18	9/16	0.57
1/2	08	3/4 - 18	3/4	0.75	3/4 - 16	11/16	0.69
5/8	10	7/8 - 18	7/8	0.87	7/8 - 14	13/16	0.81
3/4	12	1 1/16 - 16	1 1/16	1.06	1 1/16 - 14	1	0.99

Inch size	Dash size	Long pilot		Short pilot	
		Bead O.D.(inch)	Pilot length	Bead O.D. (inch)	Pilot length
3/8	06	0.52	0.28	0.52	0.19
1/2	08	0.64	0.39	0.64	0.19
5/8	10	0.77	0.39	0.77	0.19
3/4	12	0.91	0.39	0.91	0.19

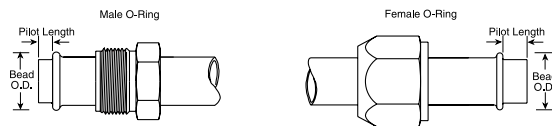

## Thread engagement nominal dimensions

### Thread engagement

Dimensions may vary due to tolerance conditions. Listed below are the thread engagement dimensions (B) which must be taken into consideration when making connection with ports or appropriate female adapters. The "B" dimension must be subtracted from the overall length (A) to insure proper connection.

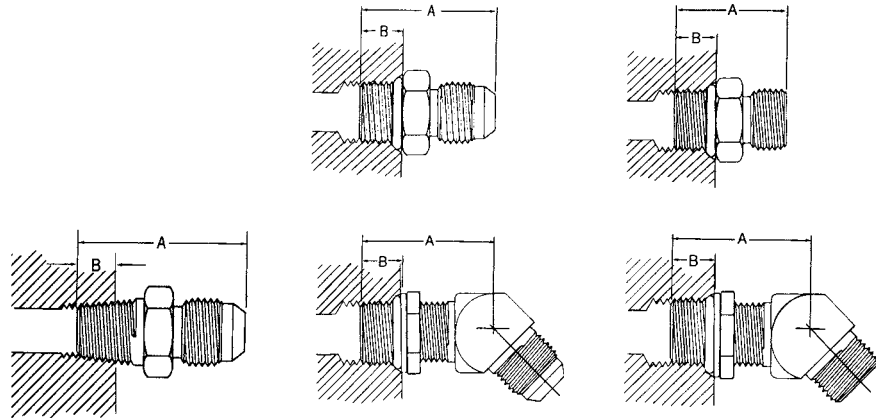

Dash size	Male pipe		SAE O-ring boss SAE J1926 with 37° flare J514		SAE O-ring boss SAE J1926 with ORS J1453	
	Straight and angled dimension "B"		Straight and adjustable dimension "B"		Straight and adjustable dimension "B"	
mm	mm	in	mm	in	mm	in
-02	6.4	0.25	-	-	-	-
-04	9.7	0.38	9.1	0.36	10.9	0.43
-05	-	-	9.1	0.36	10.9	0.43
-06	9.7	0.38	9.1	0.39	11.9	0.47
-08	12.7	0.50	10.9	0.43	14.0	0.55
-10	-	-	12.7	0.50	16.0	0.63
-12	15.7	0.62	15.0	0.59	18.5	0.73
-14	-	-	15.0	0.59	-	-
-16	17.5	0.69	15.0	0.59	18.5	0.73
-20	17.5	0.69	15.0	0.59	18.5	0.73
-24	17.5	0.69	15.0	0.59	18.5	0.73
-32	19.1	0.75	15.0	0.59	-	-

### Allowable bulkhead thickness:

For ORS					
Dash size	Hole diameter	ORS bulkhead thickness			
		Min		Max	
	in	mm	in	mm	in
-04	0.575 +0.015/-0.000	5.1	0.20	12.7	0.50
-06	0.700 +0.015/-0.000	5.1	0.20	15.0	0.59
-08	0.825 +0.015/-0.000	5.6	0.22	15.0	0.59
-10	1.015 +0.015/-0.000	5.8	0.23	15.0	0.59
-12	1.200 +0.015/-0.000	6.4	0.25	15.0	0.59
-16	1.450 +0.015/-0.000	6.4	0.25	15.2	0.60
-20	1.715 +0.015/-0.000	6.4	0.25	15.2	0.60
-24	2.030 +0.015/-0.000	6.4	0.25	15.2	0.60

For 37° Flare									
Dash size	Hole diameter	37° bulkhead thickness straights				37° bulkhead thickness shapes			
		Min		Max		Min		Max	
	in	mm	in	mm	in	mm	in	mm	in
-03	0.391 +0.016/-0.000	1.3	0.05	10.4	0.41	3.3	0.13	6.4	0.25
-04	0.453 +0.016/-0.000	1.3	0.05	10.4	0.41	3.3	0.13	7.1	0.28
-05	0.516 +0.016/-0.000	1.3	0.05	10.4	0.41	3.3	0.13	7.1	0.28
-06	0.578 +0.016/-0.000	1.3	0.05	11.2	0.44	3.3	0.13	7.6	0.30
-08	0.766 +0.016/-0.000	1.3	0.05	11.2	0.44	4.1	0.16	8.6	0.34
-10	0.891 +0.016/-0.000	1.3	0.05	11.9	0.47	4.1	0.16	9.1	0.36
-12	1.076 +0.016/-0.000	1.3	0.05	11.9	0.47	4.1	0.16	9.7	0.38
-16	1.328 +0.016/-0.000	1.3	0.05	11.9	0.47	4.1	0.16	9.7	0.38
-20	1.656 +0.031/-0.000	1.3	0.05	11.9	0.47	4.1	0.16	9.7	0.38
-24	1.906 +0.031/-0.000	1.3	0.05	11.9	0.47	4.1	0.16	9.7	0.38

## Conversion table: Inch/Millimeter

Multiply inch x 25.4 =mm

Inches & Millimeters			Inches & Millimeters			Inches & Millimeters			Inches & Millimeters		
Fract.	Inches	Millimeters	Fract.	Inches	Millimeters	Fract.	Inches	Millimeters	Fract.	Inches	Millimeters
1/64	0.016	0.397	17/64	0.266	6.747	33/64	0.516	13.097	49/64	0.766	19.447
1/32	0.031	0.794	9/32	0.281	7.144	17/32	0.531	13.494	25/32	0.781	19.844
3/64	0.047	1.191	19/64	0.297	7.541	35/64	0.547	13.891	51/64	0.797	20.241
1/16	0.063	1.588	5/16	0.313	7.938	9/16	0.563	14.288	13/16	0.813	20.638
5/64	0.078	1.984	21/64	0.328	8.334	37/64	0.578	14.684	53/64	0.828	21.034
3/32	0.094	2.381	11/32	0.344	8.731	19/32	0.594	15.081	27/32	0.844	21.431
7/64	0.109	2.778	23/64	0.359	9.128	39/64	0.609	15.478	55/64	0.859	21.828
1/8	0.125	3.175	3/8	0.375	9.525	5/8	0.625	15.875	7/8	0.875	22.225
9/64	0.141	3.572	25/64	0.391	9.922	41/64	0.641	16.272	57/64	0.891	22.622
5/32	0.156	3.969	13/32	0.406	10.319	21/32	0.656	16.669	29/32	0.906	23.019
11/64	0.172	4.366	27/64	0.422	10.716	43/64	0.672	17.066	59/64	0.922	23.416
3/16	0.188	4.763	7/16	0.438	11.113	11/16	0.688	17.463	15/16	0.938	23.813
13/64	0.203	5.159	29/64	0.453	11.509	45/64	0.703	17.859	61/64	0.953	24.209
7/32	0.219	5.556	15/32	0.469	11.906	23/32	0.719	18.256	31/32	0.969	24.606
15/64	0.234	5.953	31/64	0.484	12.303	47/64	0.734	18.653	63/64	0.984	25.003
1/4	0.250	6.350	1/2	0.500	12.700	3/4	0.750	19.050	1	1.000	25.400

## Conversion table: Pressure

(Per SAE J517 Section A)

Mpa	Bar	PSI	Mpa	Bar	PSI	Mpa	Bar	PSI	Mpa	Bar	PSI
0.25	2.5	35	4.2	42	600	20	200	2900	77	770	11000
0.3	3	45	4.3	43	625	21	210	3000	78	780	11250
0.35	3.5	50	4.9	49	700	22.4	224	3200	80	800	11600
0.4	4	56	5	50	725	22.7	227	3250	84.0	840	12000
0.4	4	62	5.2	52	750	24.5	245	3500	87	870	12500
0.5	5	70	5.6	56	800	28	280	4000	98	980	14000
0.6	6	90	6.1	61	875	29.7	297	4250	112	1120	16000
0.7	7	100	7	70	1000	31.5	315	4500	119	1190	17000
0.8	8	112	7.8	78	1125	33.5	335	4800	122	1220	17500
0.85	8.5	125	8.4	84	1200	35	350	5000	140	1400	20000
1	10	140	8.7	87	1250	38.5	385	5500	157	1570	22500
1.05	10.5	150	9.8	98	1400	40	400	5800	160	1600	23200
1.25	12.5	180	10	100	1450	42	420	6000	168	1680	24000
1.4	14	200	10.5	105	1500	43.5	435	6250	175	1750	25000
1.6	16	225	11.2	112	1600	45.5	455	6500	210	2100	30000
1.7	17	250	11.3	113	1625	49	490	7000	245	2450	35000
2.1	21	300	12.2	122	1750	52.5	525	7500	280	2800	40000
2.4	24	350	14	140	2000	56	560	8000	315	3150	45000
2.6	26	375	15.7	157	2250	59.5	595	8500	350	3500	50000
2.8	28	400	16.8	168	2400	61	610	8750			
3.5	35	500	17.5	175	2500	63	630	9000			
3.9	39	565	19.2	192	2750	70	700	10000			

A new method for calculating the equivalent metric conversion to Mpa from psi was utilized. This method provides an extremely easy and consistent method of conversion to arrive at a rounded

metric units using 7 Mpa for each 1000 psi. The resulting Mpa pressure is never more than 1.7% higher than the mathematically correct Mpa unit when the pressure is higher than 250 psi. All

operating pressures of SAE J517 hoses are above 250 psi except for most of 100R4 and the 76mm (-48) and larger sizes of 100R5. Therefore all files of

previous test results should not be compromised

## Assembly torque

### Recommended parallel connection assembly torque

Danfoss recommends that a torque wrench be used to assure proper fitting assembly of these connections.

The values listed are for steel connections. Contact Danfoss for torque values for other materials.

#### Straight thread O-Ring boss low pressure with 37° (SAEJ514)

Dash size	Thread size (inches)	Jam nut or straight fitting torque lb.-ft.	Jam nut or straight fitting torque newton meters
-03	3/8-24	8-9	12-13
-04	7/16-20	13-15	18-20
-05	1/2-20	14-15	19-21
-06	9/16-18	23-24	32-33
-08	3/4-16	40-43	55-57
-10	7/8-14	43-48	59-64
-12	1 1/16-12	68-75	93-101
-14	1 3/16-12	83-90	113-122
-16	1 5/16-12	112-123	152-166
-20	1 5/8-12	146-161	198-218
-24	1 7/8-12	154-170	209-230
-32	2 1/2-12	218-240	296-325

#### Straight thread O-Ring boss high pressure with ORS (J1453)

Dash size	Thread size (inches)	Jam nut or straight fitting torque lb.-ft.	Jam nut or straight fitting torque newton meters
-03	3/8-24	8-10	11-13
-04	7/16-20	14-16	20-22
-05	1/2-20	18-20	24-27
-06	9/16-18	24-26	33-35
-08	3/4-16	50-60	68-78
-10	7/8-14	72-80	98-110
-12	1 1/16-12	125-135	170-183
-14	1 3/16-12	160-180	215-245
-16	1 5/16-12	200-220	270-300
-20	1 5/8-12	210-280	285-380
-24	1 7/8-12	270-360	370-490

#### ORS

Dash size	Thread size (inches)	Swivel nut torque lb.-ft.	Swivel nut torque newton meters
-04	9/16-18	10-12	14-16
-06	11/16-16	18-20	24-27
-08	13/16-16	32-35	43-47
-10	1-14	44-50	60-68
-12	1 3/16-12	66-70	90-95
-16	1 7/16-12	92-100	125-135
-20	1 11/16-12	125-140	170-190
-24	2-12	148-166	200-225

#### SAE 37° (JIC)

Dash size	Thread size (inches)	Swivel nut torque lb.-ft.	Swivel nut torque newton meters	Hex turns*
-04	7/16-20	7-11	10-15	1 1/2 - 1 3/4
-05	1/2-20	11-18	15-25	1 1/2 - 1 3/4
-06	9/16-18	18-26	24-35	1 - 1 1/2
-08	3/4-16	24-37	32-50	1 1/4 - 1 3/4
-10	7/8-14	41-59	55-80	1 1/4 - 1 3/4
-12	1 1/16-12	55-89	75-120	1 - 1 1/2
-16	1 5/16-12	89-133	120-180	3/4 - 1
-20	1 5/8-12	133-207	180-280	1/2 - 3/4
-24	1 7/8-12	162-251	220-340	3/4
-32	2 1/2-12	295-479	400-650	1

\* Additional hex turns past hand tight

## Recommended parallel connection assembly torque (cont.)

Danfoss recommends that a torque wrench be used to assure proper fitting assembly of these connections.

Metric		
Thread size	Straight adapter or locknut torque	
	lb.-ft.	Newton meters
mm		
M10 x 1	13-15	18-20
M12 x 1.5	15-19	20-25
M14 x 1.5	19-23	25-30
M16 x 1.5	33-40	45-55
M18 x 1.5	37-44	50-60
M20 x 1.5	52-66	70-90
M22 x 1.5	55-70	75-95
M26 x 1.5	81-96	110-130
M27 x 2	96-111	130-150
M33 x 2	162-184	220-250
M42 x 2	170-192	230-260
M48 x 2	258-347	350-470

The values listed are for steel connections. Contact Danfoss for torque values for other materials.

DKO, light series DIN 3865				
DKO, light series				
DN	O.D.	Thread	SW torque definition 8434-1	Montage [Nm[ +10%]
5	6	M12X1,5	14	20
6	8	M14X1,5	17	25
8	10	M16X1,5	19	45
10	12	M18X1,5	22	50
12	15	M22X1,5	27	60
16	18	M26X1,5	32	70
20	22	M30X2	36	130
25	28	M36X2	41	180
32	35	M45X2	50	300
40	42	M52X2	60	320

BSPP		
Nominal thread size	Straight adapter or locknut torque	
	lb.-ft.	Newton meters
inches**		
G 1/8-28	13-15	18-20
G 1/4-19	19-23	25-30
G 3/8-19	33-40	45-55
G 1/2-14	55-70	75-95
G 3/4-14	103-118	140-160
G 1-11	162-184	220-250
G 1 1/4-11	170-192	230-260
G 1 1/2-11	258-347	350-470

\*\*"G" denotes parallel threads, other than ISO 6149. (Port connection only)

DKO, heavy series DIN 3865				
DKO, heavy series				
DN	O.D.	Thread	SW torque definition 8434-1	Montage [Nm[ +10%]
	6	M14X1,5	17	20
5	8	M16X1,5	19	35
6	10	M18X1,5	22	50
8	12	M20X1,5	24	65
10	14	M22X1,5	27	70
12	16	M24X1,5	30	85
16	20	M30X2	36	135
20	25	M36X2	41 (46)	170
25	30	M42X2	50	280
32	38	M52X2	60	320

## Assembly terms and tips

### Assembly instruction tips

#### Terms

- Skive—Removal of the cover material exposing the reinforcement prior to fitting assembly.
- Dash Size—The hose or fitting size expressed in 1/16 of an inch. The numerator of a fraction whose denominator is 16. Example: -8 or -08 is  $8/16" = 1/2"$ .
- Nipple—The part of a hose fitting that goes into the hose tube.
- Socket—The part of a hose fitting that goes over the hose cover or reinforcement.
- Mandrel—A round, properly sized, steel bar used for support during assembly of the fitting or skiving the hose cover.
- Annular Rings—A series of concentric rings inside the socket.

#### Reusable fitting tips to remember for easy assembly

- Part numbers and dash sizes are indicated on fitting sockets.
- It is essential the fitting be mated with a compatible hose style with the same dash size.
- Reusable fittings that have a notch in the socket serve as a reference for the cover skiving length.
- Familiarize yourself with the assembly instructions before you start to make an assembly.
- For hoses that require skiving, be sure to skive the hose to the proper length and down to the wire reinforcement.
- Use Aeroquip 222070 hose assembly lube liberally on both the inside of the hose and on the fitting nipple. (Check for compatibility.)
- Always cut hose square
- For volume production of hose assemblies, use Danfoss Assembly Equipment.



#### Cutting the hose

1. To determine the "J" length (cut length of hose) from "OA" (overall length) deduct "D" dimensions of both end fittings. Consult fitting information pages for "D" dimensions. For hose assemblies with SOCKETLESS<sup>®</sup> fittings, add 1/2" to "J" length.  
Tip: If the old Aeroquip<sup>®</sup> assembly was the right length, simply remove the hose fittings and measure the hose.
2. Cut the hose square.
3. Clean the hose bore.

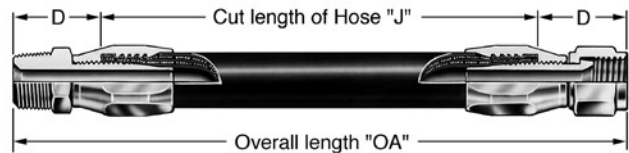

#### Phase angle (offset)

When making double elbow assemblies, the following steps should be followed to obtain the desired angle between elbows. Tighten both elbows to maximum allowable gap between socket and nipple hex. Start to position for relative angle between elbows. Finish assembly by adjusting both elbows. Backing off to get desired angle should be avoided.

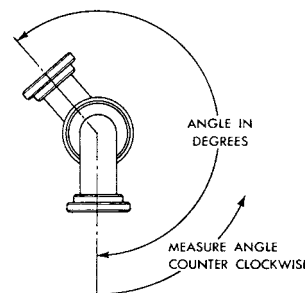

## Cleaning, inspection, testing and storage

Please for detailed recommendation follow ISO 8331:2016 Rubber and plastics hoses and hose assemblies — Guidelines for selection, storage, use and maintenance and ISO 1402:2021 Rubber and plastics hoses and hose assemblies — Hydrostatic testing. The below text is for general guidance, but we recommend to use the above standards in your operations.

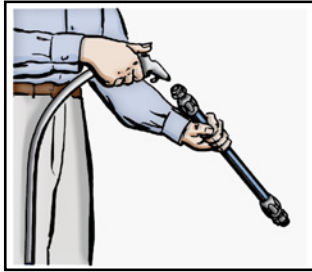

Clean

### Maintenance

Hose assemblies in operation should be inspected frequently for leakage, kinking, abrasion, corrosion or any other signs of wear or damage. Worn or damaged hose assemblies should be replaced immediately.

### Clean

At minimum a hose assembly should be blown out with clean compressed air.

Assemblies may be rinsed out with mineral spirits if the tube stock is compatible with oil, otherwise hot water at +65°C (+150°F) max. may be used.



Inspect

### Inspect

Examine hose assembly internally for cut or bulged tube, obstructions, and cleanliness.

Check for proper gap between nut and socket or hex and socket. Nuts should swivel freely. Cap the ends of the hose with plastic covers to keep clean.

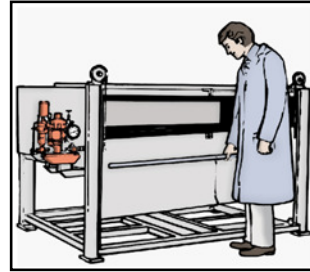

Proof test - hydrostatic

### Proof test – hydrostatic

The hose assembly should be hydrostatically tested at twice the recommended working pressure of the hose.

Test pressure should be held for not more than one minute and not less than 30 seconds. When test pressure is reached, visually inspect hose assembly for: a) Any leaks or signs of weakness. b) Any movement of the hose fitting in relation to the hose. Any of these defects are cause for rejection.

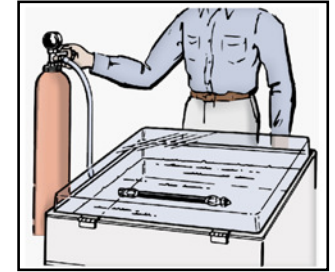

Proof test - pneumatic

### Proof test – pneumatic

Hose assemblies intended for gas or air service should be tested with air or nitrogen at 100 psi with the assembly immersed in water. Random bubbles may appear over the hose and fitting area when assembly is first pressurized. This should not be construed as a defect. However, if the bubbles persist in forming at a steady rate at any particular point on the hose, the assembly should be rejected.

Caution: Testing should be conducted in approved test stands with adequate guards to protect the operator.

### Storage and handling

Hose should be stored in a dark, dry atmosphere away from electrical equipment, and the temperature should not exceed +32°C (+90°F). Storage in the original shipping container is preferred.



## Hose and reusable fittings

### Hose and reusable fittings

#### Thru-the-cover style reusable fittings with hose

GH681, GH781, EC115, EC215

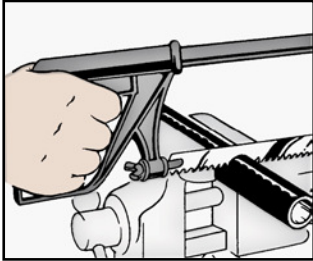

#### Step 1

Cut hose to length required using a cut-off machine.  
Clean hose bore.

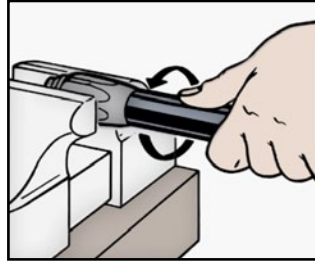

#### Step 2

Liberally lubricate hose cover with hose assembly lube.

Place socket in vise and turn hose into socket counterclockwise until it bottoms.

When assembling long lengths of hose, it may be preferred to put hose in vise just tight enough to prevent from turning, and screw socket onto the hose counterclockwise until it bottoms.

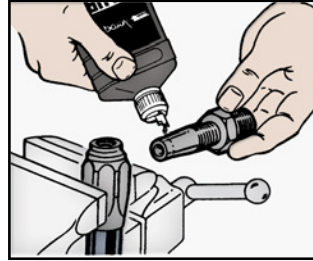

#### Step 3

Liberally lubricate nipple threads and inside of hose. Use heavy weight oil or Aeroquip® 222070 hose assembly lube.

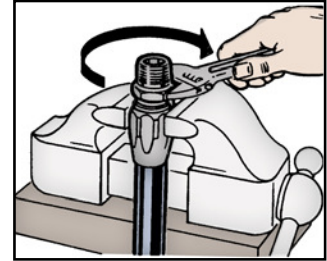

#### Step 4

Screw nipple clockwise into socket and hose. Leave 1/32" to 1/16" clearance between nipple hex and socket.

Recommendations for cleaning, inspection and testing are summarized on the previous pages. Disassemble in reverse order.

## Accessories

### Steel protective coil sleeve 900705

### Steel protective coil spring 900564

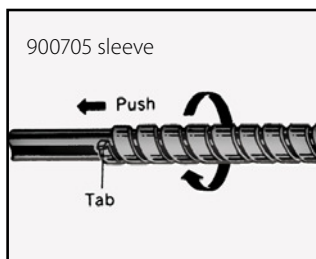

#### Step 1

Follow the appropriate assembly instructions through the assembly of one end fitting. Insert one end fitting in vise.

#### Step 2

Cut coil length. Coil should be cut to overall assembly length "OA" minus the sum of the overall length of each end fitting. ("A" dimension).

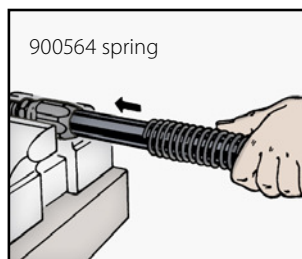

#### Step 3

##### 3a) 900705 Steel Protective Coil Sleeve

The hose and the coil should be held straight. Taping or capping the hose end can prevent frayed wire ends from snagging on the coil. Bend one end to the coil outward to form a slight tab to assist grasping. (Cut off or bend back when installation is complete.) Hold the tab with the thumb of one hand while twisting the coil clockwise approximately one foot back from the coil tab. When the coil opens up

sufficiently, slip the tab end to the coil over the hose. Move the coil onto the hose by pulling at the tab end while pushing with the other hand. Be careful not to exceed the resiliency of the coil by stretching it too far.

#### Step 4

Proceed with assembly of second end fitting.

##### 3b) 900564 Steel Protective Coil Spring

Slide coil over hose.

### Plastic coil sleeve 900952

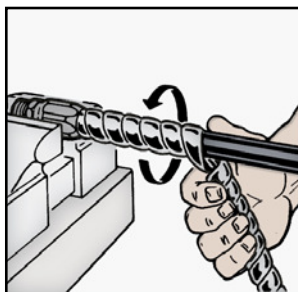

#### Step 1

Follow the appropriate hose assembly instructions through the assembly of both end fittings. Insert end fitting in vise.

#### Step 2

Cut coil length. Coil should be cut to overall assembly length "OA" minus the sum of the overall length of each end fitting. ("A" dimension).

#### Step 3

Wrap the coil on the hose.

Accessories

Accessories

Firesleeve

624

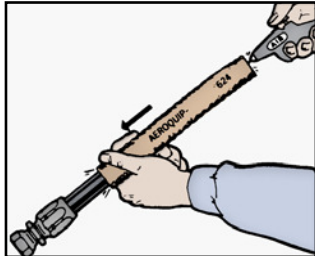

Step 1

Follow the appropriate hose assembly instructions through the assembly of one end fitting. Cut firesleeve to same length as hose; using Firesleeve End Dip (AE13702-003) dip ends of firesleeve to a depth of three quarters of an inch and allow to dry at room temperature.

Start firesleeve over cut end of hose.

**NOTE:** If applying sleeve over PTFE or stripped cover assemblies, wrap exposed wire with tape. Grasp sleeve and slip over the hose assembly as illustrated.

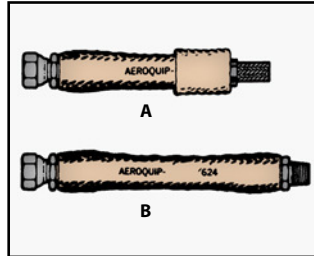

Step 2

Slide sleeve back from cut end of hose enough to allow assembly of second end fitting. (2A)

Then center sleeve so that it completely covers both sockets. (2B)

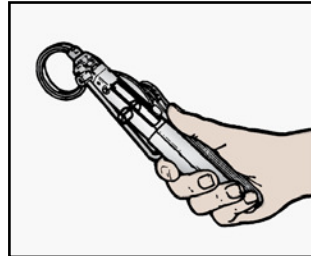

Step 3

Insert tail of band clamp into hand clamping tool.

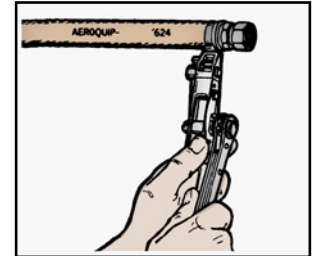

Step 4

Position band clamp over sleeve as shown and then draw tight with hand tool. Remove tool and cut free end of band clamp. Repeat on other end of assembly. To complete, bend protruding tail of clamp over clamp buckle. Also repair any scuffs or minor abrasions of firesleeve by brush application of End Dip AE13702-003.

Danfoss

# Glossary & index





## Glossary

### A

**abrasion:** external damage to a hose assembly caused by its being rubbed on a foreign object; a wearing away by friction.

**ABS:** Air-Brake Swivel absorption: regarding hose, the process of taking in fluid. Hose materials are often compared with regard to relative rates and total amounts of absorption as they pertain to specific fluids.

**acid resistant:** having the ability to withstand the action of identified acids within specified limits of concentration and temperature

**adapter, adaptor: 1)** fittings of various sizes and materials used to change an end fitting from one type to another type or one size to another. (i.e., a male SAE to male pipe adapter is often attached to a female SAE to create a male end union fitting); **2)** the grooved portion of a cam & groove coupling.

**adhesion:** the strength of bond between cured rubber surfaces or between a cured rubber surface and a non-rubber surface.

**adhesive:** a material which, when applied, will cause two surfaces to adhere.

**ambient temperature:** the temperature of the atmosphere or medium surrounding an object under consideration.

**ambient/atmospheric conditions:** The surrounding conditions, such as temperature, pressure, and corrosion, to which a hose assembly is exposed.

**amplitude of vibrations and/or lateral movement:** the distance a hose assembly deflects laterally to one side from its normal position, when this deflection occurs on both sides of the normal hose centerline.

**anchor:** a restraint applied to eliminate motion and restrain forces.

**annular:** refers to the convolutions on a hose that are a series of complete circles or rings located at right angles to the longitudinal axis of the hose (sometimes referred to as “bellows”).

**anodize, anodized:** an electrolytic

process used to deposit protective or cosmetic coatings in a variety of colors on metal; primarily used with aluminum.

**ANSI:** American National Standards Institute.

**application working pressure:** unique to customer’s application. See pressure, working.

**application:** the service conditions that determine how a hose assembly will be used.

**armor:** a protective cover slid over and affixed to a hose assembly; used to prevent over bending or for the purpose of protecting hose from severe external environmental conditions such as hot materials, abrasion, or traffic.

**assembly:** a general term referring to any hose coupled with end fittings of any style attached to one or both ends.

**ASTM:** American Society for Testing and Materials.

**attachment:** the method of securing an end fitting to a hose (e.g., banding, crimping, swaging, or screw-together 2 piece or 3 piece-style field attachable fittings).

**axial movement:** compression or elongation along the longitudinal axis.

### B

**backing:** a soft rubber layer between a hose tube and/or cover and carcass to provide adhesion.

**barb:** the portion of a fitting (coupling) that is inserted into the hose, usually comprised of two or more radial serrations or ridges designed to form a redundant seal between the hose and fitting.

**barbed and ferrule fitting:** a two-piece hose fitting comprised of a barbed insert (nipple), normally with peripheral ridges or backward-slanted barbs, for inserting into a hose and a ferrule; usually crimped or swaged.

**Barb-Tite:** a line of low pressure push-on brass hose end fittings that is a trademark of Danfoss Corporation.

**bend radius:** the radius of a bent section of hose measured to the innermost surface of the curved portion.

**bend radius, minimum:** the

smallest radius at which a hose can be used. For metal hose: the radius of a bend measured to the hose centerline, as recommended by the manufacturer.

**blister:** a raised area on the surface or a separation between layers usually creating a void or air-filled space in a vulcanized article.

**blow out force:** the force generated from the internal pressure attempting to push the fitting from the hose.

**body wire:** normally a round or flat wire helix embedded in the hose wall to increase strength or to resist collapse.

**bore: 1)** an internal cylindrical passageway, as of a tube, hose or pipe; **2)** the internal diameter of a tube, hose, or pipe.

**braid:** the woven portion of a hose used as reinforcement to increase pressure rating and add hoop strength. Various materials such as polyester, cotton or metal wire are used. A hose may have one or more braids, outside or between layers of hose material.

**braid wear:** motion between the braid and corrugated hose, which normally causes wear on the outside diameter of the corrugation and the inside diameter of the braid.

**braided ply:** a layer of braided reinforcement.

**braid-over-braid:** multiple plies of braid having no separating layers.

**brand:** a mark or symbol identifying or describing a product and/or manufacturer, that is embossed, inlaid or printed.

**brass:** a family of copper/zinc alloys.

**brazing:** a process of joining metals using a non-ferrous filler metal having a melting point that is lower than the “parent metals” to be joined, typically over +427°C (+800°F).

**bronze:** an alloy of copper, tin and zinc.

**BSPP/BSPT:** British Standard Pipe Parallel / British Standard Pipe Tapered. See fitting/coupling — pipe thread fittings.

### C

**carcass:** the fabric, cord and/or metal reinforcing section of a hose as distinguished from the hose tube or cover.

**chalking:** the formation of a powdery surface condition due to disintegration of surface binder or elastomer by weathering or other destructive environments.

**checking:** the short, shallow cracks on the surface of a rubber product resulting from damaging action of environmental conditions.

**chemical compatibility:** the relative degree to which a material may contact another without corrosion, degradation or adverse change of properties.

**chemical resistance:** the ability of a particular polymer, rubber compound, or metal to exhibit minimal physical and/or chemical property changes when in contact with one or more chemicals for a specified length of time, at specified concentrations, pressure, and temperature.

**cold flexibility:** relative ease of bending while being exposed to specified low temperature.

**collar: 1)** the portion of a fitting that is compressed by crimping to seal the hose onto the fitting barbs and create a permanent attachment; also called a ferrule. (With field attachable fittings, the lock and seal are accomplished mechanically by the collar without crimping); **2)** a raised portion on the hose shank which functions as a connection for a ferrule or other locking device or functions as a hose stop.

**collet:** a tool or die-set used to crimp a hose end fitting onto a hose. A crimping die-set is typically six to eight “fingers” designed for infinite diameter settings within a range or preset to a specific diameter for a given hose type and size. Some may have a replaceable cage.

**Coll-O-Crimp:** a line of hydraulic and pneumatic hose, hose end fittings, and fabrication equipment that is a registered trademark of Danfoss Corporation.

**combustible liquid:** a liquid having a flash point at or above +37.8°C (+100°F).

**compound:** the mixture of rubber or plastic and other materials, which are combined to give the desired properties when used in the manufacture of a product.

**compression fitting:** see fitting/coupling – compression

**conductive:** the ability to transfer electrical potential.

**configuration:** the combination of fittings on a particular assembly.

**convoluted:** description of hose or innercore having annular or helical ridges formed to enhance flexibility.

**core:** the inner portion of a hose, usually referring to the material in contact with the medium.

**corrosion:** the process of material degradation by chemical or electrochemical means.

**corrosion resistance:** ability of metal components to resist oxidation.

**corrugated hose:** hose with a carcass fluted, radially or helically, to enhance its flexibility or reduce its weight.

**coupling:** a frequently used alternative term for hose end fitting.

**cover:** the outer component usually intended to protect the carcass of a product.

**CPE:** chlorinated polyethylene, a rubber elastomer.

**cracking:** a sharp break or fissure in the surface, generally caused by strain and environmental conditions.

**crimp diameter:** the distance across opposite flats after crimping.

**crimp/crimping:** a hose end fitting attachment method utilizing a number of dies mounted in a radial configuration. The dies close perpendicular to the hose and fitting axis, compressing the collar, ferrule, or sleeve around the hose.

**cure:** the act of vulcanization. See vulcanization.

**cut off factor:** the hose length to be subtracted from the overall assembly length that allows for the hose coupling end connection extension beyond the end of the hose.

## D

**date code:** any combination of numbers, letters, symbols or other methods used by a manufacturer to identify the time of manufacture of a product.

**deburr:** to remove ragged edges from the inside diameter of a hose end.

**design factor:** a ratio used to establish the working pressure of the hose, based on the burst strength of the hose.

**displacement:** the amount of motion applied to a hose defined as inches for parallel offset and degrees for angular misalignment.

**DOT:** Department of Transportation.

**DIN:** Deutsche Industrie Norme.

**duplex assembly:** an assembly consisting of two hose assemblies, one inside the other, and connected at the ends; also known as “jacketed assemblies.”

**durometer:** an instrument for measuring the hardness of rubber and plastic compounds.

## E

**eccentricity:** the condition resulting from the inside and outside diameters not having a common center.

**effusion:** the escape, usually of gases, through a material. See permeation.

**elastic limit:** the limiting extent to which a body may be deformed and yet return to its original shape after removal of the deforming force.

**elastomer:** any one of a group of polymeric materials, usually designated thermoset, such as natural rubber, or thermoplastic, which will soften with application of heat.

**elongation:** the increase in length expressed numerically as a percentage of the initial length.

**EN:** European Normes

**ERMETO:** a steel fitting product trademarked by Danfoss Corporation.

**endurance test:** a service or laboratory test, conducted to product failure, usually under normal use conditions.

**EPDM:** Ethylene Propylene Diene Monomer; an elastomer.

**extrude/extruded/extrusion:** forced through the shaping die of an extruder; extrusion may have a solid or hollow cross section.

## F

**fabric impression:** impression formed on the rubber surface during vulcanization by contact with fabric jacket or wrapper.

**fabricator:** the producer of hose assemblies.

**fatigue:** the weakening or deterioration of a material occurring when a repetitious or continuous application of stress causes strain, which could lead to failure.

**FDA:** United States Food and Drug Administration.

**fire sleeve:** slip-on or integrally extruded sleeve used to retard the effects of fire in certain applications; most often made with silicone and/or ceramic fiber.

**fitting/coupling:** a device attached to the end of the hose to facilitate connection. The following is only a partial list of types of fittings available.

- **banjo fitting:** a through bolted designed featuring a hollow circle or “donut” attached to one end of the fitting barb so that the inner diameter is along the hose axis.

- **compression fitting:** a fitting style that seals on a mating tube by compressing an internal ferrule against the tube O.D.

- **field attachable fitting:** a fitting designed to be attached to hose without crimping or swaging. This fitting is not always a reusable type fitting.

- **flange style fittings:** pipe flanges and flanged fitting standards are listed under ANSI B16.5. Flanges are rated for pressure and listed as “American Class 150, 300, 400, 600, 900, 1,500 or 2,500.” Pressure-temperature ratings can be obtained by consulting the ANSI specification or ASME B16.5 (American Society of Mechanical Engineers). Designs vary by neck and face style, or other dimensional changes based on use. Various finishes or grooves may be applied to the face for sealing on a gasket or o-ring. Bolt holes and other dimensions are per the ANSI standard.

- **inverted flare fitting:** a fitting consisting of a male or female nut, trapped on a tube by flaring the end of the tube material to either 37° or 45°.

- **JIC fittings:** Joint Industrial Council (no longer in existence). An engineering group that established an industry standard fitting design incorporating a 37° mating surface, male and female styles. These standards are now governed by SAE.

- **o-ring fittings:** a fitting that seals by means of an elastomeric ring of a specified material.

### pipe thread fittings:

- **NPT:** National Pipe Taper. Pipe thread per ANSI B1.20.1

- **NPTF:** National Pipe Tapered for Fuels. (Same as above except dry-seal per ANSI B1.20.3)

- **NPSH:** National Pipe Straight Hose per ANSI B1.20.7

- **NPSM:** National Pipe Straight Mechanical. Straight thread per ANSI B1.20.1

- **NPSL:** National Pipe Straight Loosefit per ANSI B1.20.1

- **BSPP, BSPT:** British Standard Pipe Parallel, British Standard Pipe Taper. BS21-

- **quick connect fitting:** a fitting designed to quickly connect and disconnect. These fittings come in many styles and types.

- **split flange fitting:** a fitting consisting of a flange retainer and a flange of two halves. This design allows the flanges to be installed after the retainer has been attached to the hose, making the flange reusable. SAE code 61 and 62.

- **tube fitting:** a hose fitting of which the mating end conforms to a tube diameter. The mate or male end of a compression fitting.

**flammable gases/liquid/media:** a flammable gas, including liquefied gas, is one having a closed cup flash point below +100°F (+37.8°C) and a vapor pressure greater than 25 psi (174.2 KPa).

**flex cracking:** a surface cracking induced by repeated bending and straightening.

**flow rate:** a volume of media being conveyed in a given time period.

**fluid:** a gas or liquid medium.

**fluorocarbon:** an organic compound containing fluorine directly bonded to carbon. The ability of the carbon atom to form a large variety of structural chains gives rise to many fluorocarbons and fluorocarbon derivatives.

## Glossary

**FOR-SEAL:** a product name for a hose end configuration using an o-ring sealing method, trademarked by Danfoss Corporation.

## G

**gpm:** gallons per minute.

## H

**heat resistance:** the property or ability to resist the deteriorating effects of elevated temperatures.

**helix:** a shape formed by spiraling a wire or other reinforcement around the cylindrical body of a hose; typically used in suction hose.

**hose:** a flexible conduit consisting of a tube, reinforcement, and usually an outer cover.

**hydrostatic testing:** the use of liquid pressure to test a hose or hose assembly for leakage, twisting, and/or hose change-in-length.

**Hytrel:** registered trademark of Chemours.

## I

**I.D.:** inside diameter.

**identification yarn:** a yarn of single or multiple colors, usually embedded in the hose wall, used to identify the manufacturer.

**impression:** a design formed during vulcanization in the surface of a hose by a method of transfer, such as fabric impression or molded impression.

**impulse:** an application of force in a manner to produce sudden strain or motion, such as hydraulic pressure applied in a hose.

**innertube:** the innermost layer of a hose; the hose material in contact with the medium.

**insert:** optional term for nipple. See nipple.

**interlocking clamp:** a clamp which engages the fitting in a manner which prevents the clamp from sliding off the fitting, typically a bolt or U-bolt style with interlocking fingers which engage an interlock ring on the fitting.

**interlocking ferrule:** a ferrule, which physically attaches to the fitting preventing the ferrule from sliding off the fitting.

**ISO:** International Organization for Standardization.

## J

**jacket:** a seamless tubular braided or woven ply generally on the outside of a hose.

**JIC:** see fitting/coupling—JIC.

## K

**kinking:** a temporary or permanent distortion of the hose induced by bending beyond the minimum bend radius.

## L

**layline:** the line of printed information that runs parallel on the side of a manufactured hose giving details such as part number, psi rating, hose size, and manufacturing data.

**layer:** a single thickness of rubber or fabric between adjacent parts.

**loop installation:** the assembly is installed in a loop or “U” shape, and is most often used when frequent and/or large amounts of motion are involved.

**LPG, LP Gas:** liquefied petroleum gas.

## M

**MAWP:** see pressure, maximum allowable working.

**mandrel built:** a hose fabricated and/or vulcanized on a mandrel.

**manufacturer’s identification:** a code symbol used on or in some hose to indicate the manufacturer.

**media, medium:** the substance(s) being conveyed through a system.

## N

**NAHAD:** National Association of Hose & Accessories Distributors.

**Neoprene:** a registered trademark of Chemours.

**nipple:** the internal member or portion of a hose fitting.

**nitrile rubber (NB/Buna-N):** a family of acrylonitrile elastomers used extensively for industrial hose.

**nominal:** a size indicator for reference only.

**nomograph:** a chart used to compare hose size to flow rate to recommended velocity.

**non-conductive:** the inability to transfer an electrical charge.

**NPT/NPTF:** national pipe threads. See fitting/coupling — pipe thread fittings.

**nylon:** a family of polyamide materials.

## O

**OAL:** see overall length

**O.D.:** outside diameter.

**OE/OEM:** original equipment manufacturer.

**oil resistance:** the ability of the materials to withstand exposure to oil.

**oil swell:** the change in volume of a rubber article resulting from contact with oil.

**operating conditions:** the pressure, temperature, motion, and environment to which a hose assembly is subjected.

**o-ring fitting:** see fitting/coupling—o-ring.

**overall length (OAL):** the total length of a hose assembly, which consists of the free hose length plus the length of the coupling(s).

**oxidation:** the reaction of oxygen on a material, usually evidenced by a change in the appearance or feel of the surface or by a change in physical properties.

**ozone cracking:** the surface cracks, checks, or crazing caused by exposure to an atmosphere containing ozone.

**ozone resistance:** the ability to withstand the deteriorating effects of ozone (generally cracking).

## P

**permanent fitting:** the type of fitting which, once installed, may not be removed for re-use.

**permeation:** the process of migration of a substance into and through another, usually the movement of a gas into and through a hose material; the rate of permeation is specific to the substance, temperature, pressure, and the material being permeated.

**pin pricked:** perforations through the cover of a hose to vent permeating gases.

**pitch: 1)** the distance from one point on a helix to the corresponding point on the next turn of the helix, measured parallel to the axis; **2)** the distance between the two peaks of adjacent corrugation or convolution.

**plating:** a material, usually metal, applied to another metal by electroplating, for the purpose of reducing corrosion; typically a more noble metal such as zinc is applied to steel.

**ply:** an individual layer in hose construction.

**polymer:** a macromolecular material formed by the chemical combination of monomers, having either the same or different chemical compositions.

**pressure:** force ÷ unit area. For purposes of this document, refers to PSIG (pounds per square inch gauge).

**pressure drop:** the measure of pressure reduction or loss over a specific length of hose.

**pressure, burst:** the pressure at which rupture occurs.

**pressure, maximum allowable working:** the maximum pressure at which a hose or hose assembly is designed to be used. Abbreviated as MAWP.

**pressure, working:** the maximum pressure to which a hose will be subjected, including the momentary surges in pressure, which can occur during service. Abbreviated as WP.

**psi:** pounds per square inch.

**PVC:** polyvinyl chloride. A low cost thermoplastic material typically used in the manufacture of industrial hoses. The operating temperature range is -295.5°C to +954.4°C (-500°F to +1750°F).

## R

**reinforcement:** the strengthening members, consisting of either fabric, cord, and/or metal, of a hose. See ply.

**reusable fitting/coupling:** see fitting/coupling—field attachable fittings.

**RMA:** The Rubber Manufacturers Association, Inc.

**S**

**SAE:** Society of Automotive Engineers.

**shank:** that portion of a fitting, which is inserted into the bore of a hose.

**skive:** the removal of a short length of cover and/or tube to permit the attachment of a fitting directly over the hose reinforcement.

**sleeve:** a metal cylinder, which is not physically attached to the fitting, for the purpose of forcing the hose into the serrations of the fitting.

**smooth bore:** a term used to describe the type of innercore in a hose.

**specification:** a document setting forth pertinent details of a product.

**spiral:** a method of applying reinforcement in which there is not interlacing between individual strands of the reinforcement.

**spring guard:** a helically wound component applied internally or externally to a hose assembly, used for strain relief, abrasion resistance, collapse resistance.

**standard:** a document, or an object for physical comparison, for defining product characteristics, products, or processes, prepared by a consensus of a properly constituted group of those substantially affected and having the qualifications to prepare the standard for use.

**static wire:** wire incorporated in a hose to conduct static electricity.

**stem:** see nipple.

**Sub-Zero:** a low temperature resistant hose that is a registered trademark of Danfoss Corporation.

**surge (spike):** a rapid and transient rise in pressure.

**swelling:** an increase in volume or linear dimension of a specimen immersed in liquid or exposed to a vapor.

**T**

**Thick-Flange:** a hose end fitting that is trademarked by Danfoss Corporation.

**tube:** the innermost continuous all-rubber or plastic element of a hose.

**tube fitting:** see fitting/coupling—tube.

**tubing:** a non-reinforced, homogeneous conduit, generally of circular cross-section.

**V**

**vacuum resistance:** the measure of a hoses ability to resist negative gauge pressure.

**vibration:** amplitude motion occurring at a given frequency.

**viscosity:** the resistance of a material to flow.

**vulcanization:** a process during which a rubber compound, through a change in its chemical structure, improves or extends elastic properties over a greater range of temperature.

**W**

**weathering:** the surface deterioration of a hose cover during outdoor exposure, as shown by checking, cracking, crazing and chalking.

**wire reinforced:** a hose containing wires to give added strength, increased dimensional stability and crush resistance. See reinforcement.

**working temperature:** the temperature range of the application; may include the temperature of the fluid conveyed or the environmental conditions the assembly is exposed to in use.

**WP:** working pressure.



## Index

<b>PART #</b>	<b>PAGE #</b>	<b>PART #</b>	<b>PAGE #</b>	<b>PART #</b>	<b>PAGE #</b>
GH681.....	36	1A-BT.....	86	1G-JF.....	93
FC510.....	37	1A-GG.....	87	1G-KF.....	94
GH781.....	38	1A-MG.....	88	1G-DL.....	95
EC881.....	39	1A-FJ.....	89	1G-DLA.....	96
GH195.....	40	1A-FJ.....	90	1G-DLB.....	97
GH120.....	41	1A-FJA.....	91	1G-DK.....	98
GH425.....	42	1A-FJB.....	92	1G-DS.....	99
GH493.....	43	1A-JF.....	93	1G-DSA.....	100
GH506.....	44	1A-KF.....	94	1G-DSB.....	101
FC500.....	45	1A-DL.....	95	1G-EK.....	102
GH466.....	46	1A-DLA.....	96	1G-LG.....	103
EC600.....	47	1A-DLB.....	97	1G-MM.....	104
EC850.....	48	1A-DK.....	98	1G-GM.....	105
EC525.....	49	1A-DS.....	99	1G-MP.....	106
EC810.....	50	1A-DSA.....	100	1G-MP.....	107
FC619.....	51	1A-DSB.....	101	1G-FR.....	108
2661.....	52	1A-EK.....	102	1G-FRA.....	109
GH585.....	53	1A-LG.....	103	1G-FRB.....	110
FC310.....	54	1A-MM.....	104	1G-FRC.....	111
SH222.....	55	1A-GM.....	105	1G-MR.....	112
GH507.....	56	1A-MP.....	106	1G-FL.....	113
GH435.....	57	1A-MP.....	107	1G-FLA.....	114
GH681B.....	58	1A-FR.....	108	1G-FLB.....	115
EC881B.....	59	1A-FRA.....	109	1G-FLB.....	116
GH425B.....	60	1A-FRB.....	110	1G-FH.....	117
		1A-FRC.....	111	1G-FHA.....	118
EC110.....	64	1A-MR.....	112	1G-FHB.....	119
EC115.....	65	1A-FL.....	113		
EC210.....	66	1A-FLA.....	114	GA10933.....	122
EC215.....	67	1A-FLB.....	115	GA17537.....	123
EC118.....	68	1A-FLB.....	116	GA17544.....	124
EC082.....	69	1A-FH.....	117	11.013.....	125
EC426.....	70	1A-FHA.....	118	11.721.....	126
EC512.....	71	1A-FHB.....	119	11.839.....	127
EC420.....	72			11.840.....	128
EC615.....	73	1G-BJ.....	81	11.005.....	129
WH004.....	74	1G-BF.....	82	G4103.....	130
WH005.....	75	1G-BFA.....	83	G185287.....	131
WH006.....	76	1G-BFB.....	84	G185264.....	132
WH007.....	77	1G-BP.....	85	4203.....	133
EC330.....	78	1G-BT.....	86	G4614.....	134
		1G-GG.....	87	G4645.....	135
1A-BJ.....	81	1G-MG.....	88	G4690.....	136
1A-BF.....	82	1G-FJ.....	89	11.420.....	137
1A-BFA.....	83	1G-FJ.....	90	11.143.....	138
1A-BFB.....	84	1G-FJA.....	91	11.139.....	139
1A-BP.....	85	1G-FJB.....	92		

				Index	
PART #	PAGE #	PART #	PAGE #	PART #	PAGE #
00110.....	142	1T-FJA.....	190	6S-FJ.....	189
03310.....	142	1T-FJB.....	191	6S-FJA.....	190
4W.....	143	1T-FR.....	192	6S-FJB.....	191
000T8.....	143	1T-FRA.....	193	6S-FR.....	192
10411.....	144	1T-FRB.....	194	6S-FRA.....	193
20411.....	145	1T-BP.....	195	6S-FRB.....	194
20441.....	146	1T-BP.....	196	6S-BP.....	196
20491.....	147	1T-BFA.....	197	6S-BFA.....	197
10511.....	148	1T-BFB.....	198	6S-BFB.....	198
20511.....	149				
20541.....	150	4S-DL.....	175	GCC2453.....	199
20591.....	151	4S-EK.....	176	G74446.....	200
87311.....	152	4S-DS.....	177	G74453.....	201
87341.....	153	4S-DSA.....	178		
87391.....	154	4S-DSB.....	179	1W-BF.....	204
16711.....	155	4S-FL.....	180	1W-BFA.....	205
26711.....	156	4S-FLA.....	181	1W-BFB.....	206
26711D.....	157	4S-FLB.....	182	1W-BP.....	207
26741.....	158	4S-FH.....	183	1W-CT.....	208
26791.....	159	4S-FHA.....	184	1W-CTA.....	209
14211.....	160	4S-FHB.....	185	1W-CTB.....	210
24211D.....	160	4S-CT.....	186	1W-FJ.....	211
24211.....	161	4S-CTA.....	187	1W-FJA.....	212
24241.....	162	4S-CTB.....	188	1W-FJB.....	213
24291.....	163	4S-FJ.....	189	1W-MJ.....	214
12611.....	164	4S-FJA.....	190	1W-DL.....	215
22611D.....	164	4S-FJB.....	191	1W-DLA.....	216
22611.....	165	4S-FR.....	192	1W-DLB.....	217
22641.....	166	4S-FRA.....	193	1W-DK.....	218
22691.....	167	4S-FRB.....	194	1W-DS.....	219
15611.....	168	4S-BP.....	195	1W-DSA.....	220
15611SW.....	169	4S-BP.....	196	1W-DSB.....	221
60011.....	170	4S-BFA.....	197	1W-EK.....	222
		4S-BFB.....	198	1W-MP.....	223
				1W-FR.....	224
1T-DK.....	174			1W-FRA.....	225
1T-DL.....	175	6S-DS.....	177	1W-FRB.....	226
1T-EK.....	176	6S-DSA.....	178	1W-FL.....	227
1T-DS.....	177	6S-DSB.....	179	1W-FLA.....	228
1T-DSA.....	178	6S-FL.....	180	1W-FLB.....	229
1T-DSB.....	179	6S-FLA.....	181	1W-FH.....	230
1T-FL.....	180	6S-FLB.....	182	1W-FHA.....	231
1T-FLA.....	181	6S-FH.....	183	1W-FHB.....	232
1T-FLB.....	182	6S-FHA.....	184	1W-FHB.....	233
1T-FH.....	183	6S-FHB.....	185	1W-FHB.....	234
1T-FHA.....	184	6S-CT.....	186		
1T-FHB.....	185	6S-CTA.....	187		
1T-FJ.....	189	6S-CTB.....	188		

## About Danfoss Power Solutions

**Danfoss Power Solutions** is a global manufacturer and supplier of high-quality hydraulic and electric components. We specialize in providing state-of-the-art technology and solutions that excel in the harsh operating conditions of the mobile off-highway market as well as the marine sector. Building on our extensive applications expertise, we work closely with you to ensure exceptional performance for a broad range of applications. We help you and other customers around the world speed up system development, reduce costs and bring vehicles and vessels to market faster.

We offer you expert worldwide support for ensuring the best possible solutions for outstanding performance. And with an extensive network of Global Service Partners, we also provide you with comprehensive global service for all of our components.

Danfoss Power Solutions – your strongest partner in mobile hydraulics and mobile electrification.

### Products we offer:

- Aeroquip® by Danfoss
- Boston® by Danfoss
- DCV directional control valves
- Electric converters
- Electric machines
- Electric motors
- Hydrostatic motors
- Hydrostatic pumps
- Orbital motors
- PLUS+1® controllers
- PLUS+1® displays
- PLUS+1® joysticks and pedals
- PLUS+1® operator interfaces
- PLUS+1® sensors
- PLUS+1® software services, support and training
- PLUS+1® software
- Position controls and sensors
- PVG proportional valves
- SEL® by Danfoss
- Steering components and systems
- Synflex™ Optimum by Danfoss
- Telematics
- Weatherhead® by Danfoss
- Winner™ by Danfoss

Go to [www.danfoss.com](http://www.danfoss.com) for further product information.

#### Danfoss Power Solutions (US) Company

2800 East 13th Street  
Ames, IA 50010, USA  
Phone: +1 515 239 6000

#### Danfoss Power Solutions GmbH & Co. OHG

Krokamp 35  
D-24539 Neumünster, Germany  
Phone: +49 4321 871 0

#### Danfoss Power Solutions ApS

Nordborgvej 81  
DK-6430 Nordborg, Denmark  
Phone: +45 7488 2222  
Inside.Sales.DPS.EMEA@danfoss.com

#### Danfoss Power Solutions Trading (Shanghai) Co. Ltd.

Building #22, No. 1000 Jin Hai Rd  
Jin Qiao, Pudong New District  
Shanghai, China 201206  
Phone: +86 21 3418 5200

Danfoss can accept no responsibility for possible errors in catalogs, brochures, and other printed material. Danfoss reserves the right to alter its products without notice. This also applies to products already on order provided that such alterations can be made without subsequent changes being necessary in specifications already agreed. All trademarks in this material are property of the respective companies. Danfoss and the Danfoss logotype are trademarks of Danfoss A/S. All rights reserved.